

**PROPOSAL TO AMEND
THE CODE OF ORDINANCES,
TOWN OF ROLESVILLE, NORTH CAROLINA
Case Number UDO TA 19-07**

WHEREAS, North Carolina General Statute Section NC Chapter 160A; Article 19, Part, Zoning; Section 160A-381, Grant of power; authorizes local governments by ordinance to regulate and restrict the height, number of stories and size of buildings and other structures, the percentage of lots that may be occupied, the size of yards, courts and other open space, the density of population, the location and use of buildings, structures and land'

WHEREAS, the Town of Rolesville Board of Commissioners firmly believes that it is in the public interest to amend the Town's Unified Development Ordinance described herein below.

NOW, THEREFORE, BE IT ORDAINED BY THE TOWN BOARD OF COMMISSIONERS OF THE TOWN OF ROLESVILLE, NORTH CAROLINA:

SECTION 1. That Article 10: Parking and Loading Requirements; Section 10.1 Off-Street Parking Requirements; Subsection 10.1.4, be amended to read as follows:

- Addition
- Deletion
- Alteration (additions are *italicized* and deletions are ~~struckthrough~~)

~~10.1.4~~ Parking space sizes will be governed by the following dimensions:

- ~~_____ Parallel stall 20' x 9.0'~~
- ~~_____ Angle stall 19' x 8.5'~~
- ~~_____ 90° stall 19' x 9.0'~~

~~10.1.5~~ Minimum aisle widths shall be:

Parking Angle	Aisle Width in Feet	
	One-Way Traffic	Two-Way Traffic
0-15°	12	24 (0° only)
16-37°	11	_____
38-37°	13	_____
58-74°	18	_____
75-90°	24	24

~~10.1.6~~ A safe means of ingress and egress shall be provided for all parking spaces and driveways for uses other than single and two family residential and shall be at least twenty four (24) feet wide.

“10.1.4 Parking Bay Dimensional Standards:

<u>Use</u>	<u>Type of Bay</u>	<u>Dimensions (ft.)</u>	<u>Travel Lane Width (ft.)</u>	<u>Travel Lane + Parking Bay</u>
<u>Residential</u>	<u>Uncovered Driveway</u>	<u>9W x 18L</u>	<u>N/A</u>	<u>N/A</u>
<u>Residential</u>	<u>Parking Lot/Deck</u>	<u>9W x 18L</u>	<u>24</u>	<u>60</u>
<u>Nonresidential</u>	<u>Parking Lot/Deck</u>	<u>9W x 18L</u>	<u>24</u>	<u>60</u>
<u>Parallel parking</u>	<u>On-Street Parking</u>	<u>8W x 22L</u>	<u>N/A</u>	<u>N/A</u>
<u>90 degree parking</u>	<u>Perpendicular Parking</u>	<u>9W x 18L</u>	<u>24</u>	<u>60</u>
<u>60 degree parking</u>	<u>Angle Parking</u>	<u>9W x 22L</u>	<u>18*</u>	<u>62*</u>
<u>45 degree parking</u>	<u>Angle Parking</u>	<u>9W x 21L</u>	<u>14*</u>	<u>56*</u>
<u>30 degree parking</u>	<u>Angle Parking</u>	<u>9W x 18L</u>	<u>14*</u>	<u>50*</u>
<u>Handicap Bay</u>	<u>Parking Lot/Deck</u>	<u>16W x 18L</u>	<u>24</u>	<u>60</u>

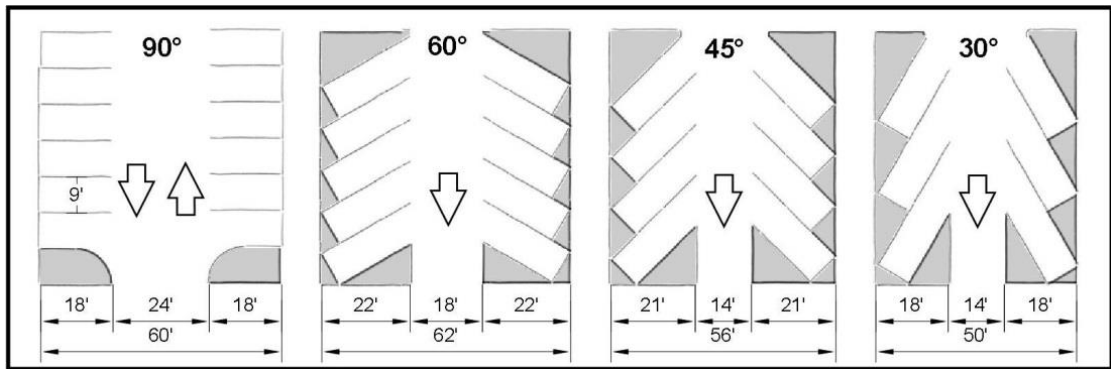

* If angle degree parking bay is design in opposite angle direction on either side the travel lane the width will be 24 ft. The Travel Lane + Parking Bay width will include the increase travel lane width.

10.1.5 [Reserved]

10.1.6 [Reserved]”

SECTION 2. Effective Date. This ordinance shall become effective on the date of its adoption by the Board of Commissioners.

Adopted this ____ day of _____, 2019 by the Town of Rolesville Board of Commissioners.

Frank Eagles
Town of Rolesville Mayor

CERTIFICATION

I, _____, Town Clerk for the Town of Rolesville, North Carolina, do hereby certify the foregoing to be a true copy of an ordinance duly adopted at the meeting of the Town Board of Commissioners held on this ___ day of _____, 2019.

In witness whereof, I have hereunto set my hand and caused the seal of the Town of Rolesville to be affixed this ___ day of _____, 2019.

(seal)

Robin Peyton
Town Clerk