

# HARRIS CREEK INTERCEPTOR IMPROVEMENTS

ROLESVILLE, NORTH CAROLINA

PROJECT NUMBER: AWH-21002

DATE: xxxxx

**SURVEY BY:**  
 BATEMAN CIVIL SURVEY COMPANY  
 2424 RELIANCE AVENUE, APEX, NC 27539  
 TOPOGRAPHIC DECEMBER 22, 2019  
 ALTA SURVEY DECEMBER 12, 2019  
 STEVEN P CARSON, PLS  
 NC LICENSE # 4752  
 919-577-1081

SHEET INDEX	
C0.00	PROJECT NOTES AND SITE DETAILS
C5.00	PLAN AND PROFILE - HARRIS CREEK INTERCEPTOR STA. 34+00.00 THRU STA. 43+00.00
C5.01	PLAN AND PROFILE - HARRIS CREEK INTERCEPTOR STA. 43+00.00 THRU STA. 53+00.00
C5.02	PLAN AND PROFILE - HARRIS CREEK INTERCEPTOR STA. 52+00.00 THRU STA. 61+00.00
C5.03	PLAN AND PROFILE - HARRIS CREEK INTERCEPTOR STA. 61+00.00 THRU STA. 64+00.00
C8.01	SANITARY SEWER DETAILS
C8.02	EROSION CONTROL DETAILS

**PUBLIC UTILITY IMPROVEMENT QUANTITIES OF SEWER MAIN & MANHOLES**

SIZE	LENGTH
18" PVC (LF)	418 LF
24" PVC (LF)	3,469 LF
NUMBER OF MANHOLES = 13	

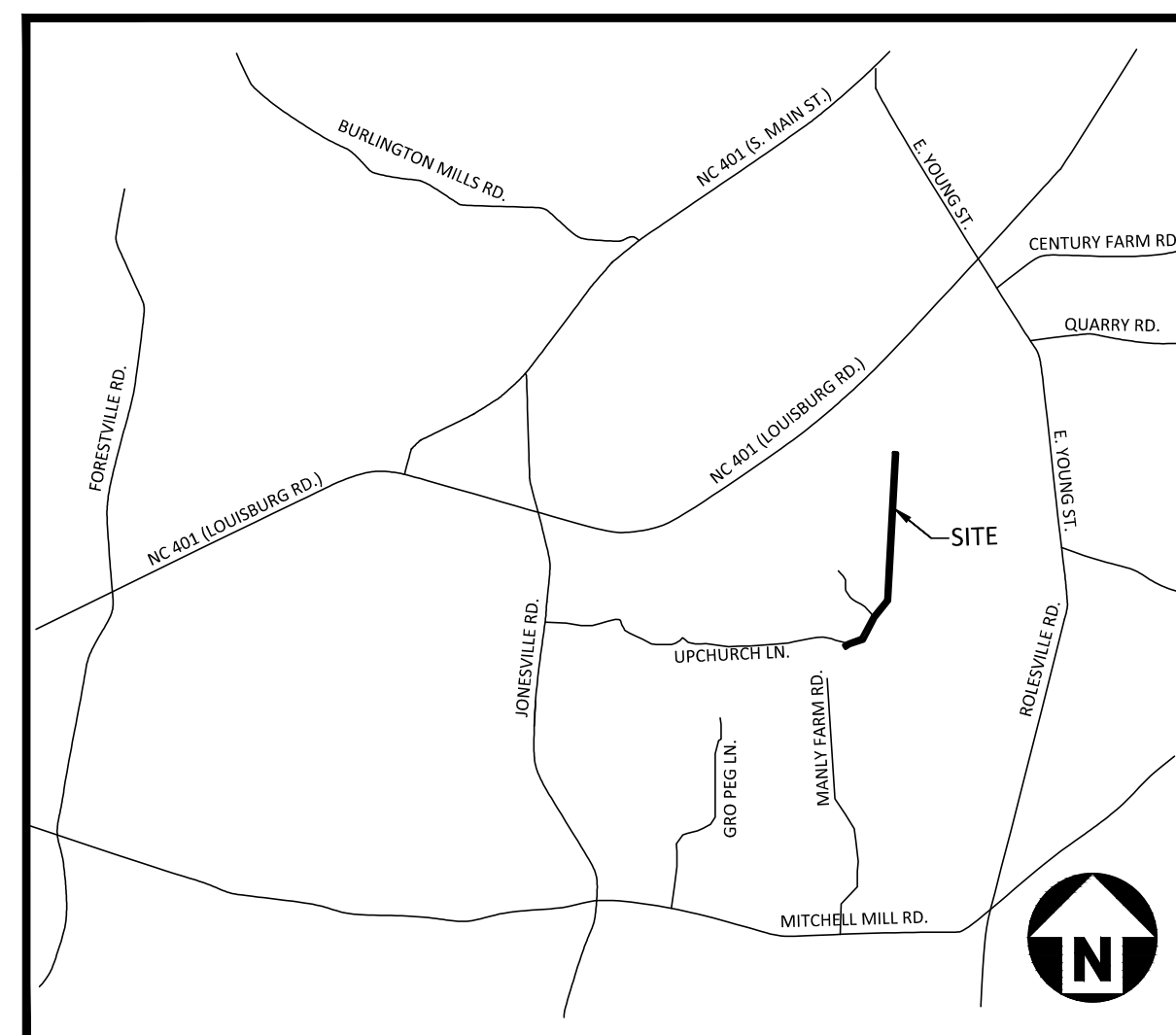

**VICINITY MAP**  
 N.T.S.

**SITE PERMITTING APPROVAL**

Water and Sewer Permits (if applicable)

The City of Raleigh consents to the connection and extension of the City's Public Sewer System as shown on this plan. The material and construction methods used for this project shall conform to the standards and specifications of the City's Public Utilities Handbook, City of Raleigh Public Utilities Department Permit # \_\_\_\_\_

The City of Raleigh consents to the connection and extension of the City's Public Water System as shown on this plan. The material and construction methods used for this project shall conform to the standards and specifications of the City's Public Utilities Handbook, City of Raleigh Public Utilities Department Permit # \_\_\_\_\_

The City of Raleigh consents to the connection to its public sewer system and extension of the private sewer collection system as shown on this plan. The material and construction methods used for this project shall conform to the standards and specifications of the City's Public Utilities Handbook.  
 City of Raleigh Public Utilities Department Permit # \_\_\_\_\_

**CITY OF RALEIGH - PLANS AUTHORIZED FOR CONSTRUCTION**

Electronic Approval: This approval is being issued electronically. This approval is valid only upon the signature of a City of Raleigh Review Officer below. The City will retain a copy of the approved plans. Any work authorized by this approval must proceed in accordance with the plans kept on file with the City. This electronic approval may not be edited once issued. Any modification to this approval once issued will invalidate this approval.

City of Raleigh Development Approval \_\_\_\_\_  
 City of Raleigh Review Officer \_\_\_\_\_

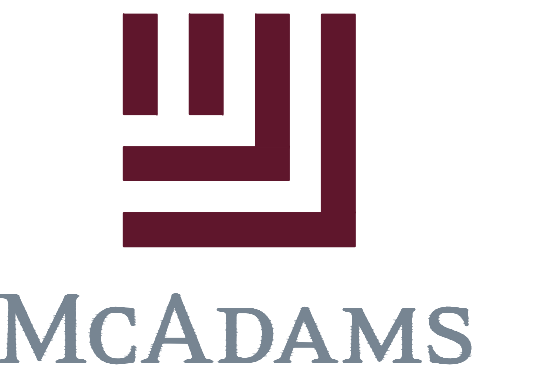

**McADAMS**  
 The John R. McAdams Company, Inc.  
 2905 Meridian Parkway  
 Durham, NC 27713

phone 919. 361. 5000  
 fax 919. 361. 2269  
 license number: C-0293, C-187

www.mcadamsco.com

**CONTACT**

MIKE SANCHEZ  
 sanchez@mcadamsco.com  
 PHONE: 919. 361. 5000

**CLIENT**

ASHTON RALEIGH RESIDENTIAL, LLC.  
 5711 SIX FORKS ROAD, SUITE 300  
 RALEIGH, NORTH CAROLINA 27609  
 PHONE: 919. 232. 3695  
 CONTACT: BOB MISHLER

**PROJECT DIRECTORY**

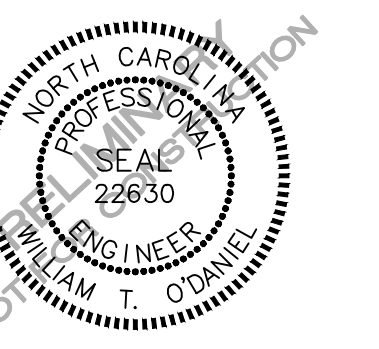

**REVISIONS**

NO. DATE

**HARRIS CREEK INTERCEPTOR IMPROVEMENTS**

ROLESVILLE, NORTH CAROLINA  
 PROJECT NUMBER: AWH-21002

**CITY OF RALEIGH PUBLIC UTILITIES  
STANDARD UTILITY NOTES (AS APPLICABLE)**

1. ALL MATERIALS & CONSTRUCTION METHODS SHALL BE IN ACCORDANCE WITH CITY OF RALEIGH DESIGN STANDARDS, DETAILS & SPECIFICATIONS (REFERENCE: CORPUD HANDBOOK, CURRENT EDITION)
2. UTILITY SEPARATION REQUIREMENTS:
  - a. A DISTANCE OF 100' SHALL BE MAINTAINED BETWEEN SANITARY SEWER & ANY PRIVATE OR PUBLIC WATER SUPPLY SOURCE SUCH AS AN IMPOUNDED RESERVOIR USED AS A SOURCE OF DRINKING WATER. IF ADEQUATE LATERAL SEPARATION CANNOT BE ACHIEVED, FERROUS SANITARY SEWER PIPE SHALL BE SPECIFIED & INSTALLED TO WATERLINE SPECIFICATIONS. HOWEVER, THE MINIMUM SEPARATION SHALL NOT BE LESS THAN 25' FROM A PRIVATE WELL OR 50' FROM A PUBLIC WELL.
  - b. WHEN INSTALLING WATER &/OR SEWER MAINS, THE HORIZONTAL SEPARATION BETWEEN UTILITIES SHALL BE 10'. IF THIS SEPARATION CANNOT BE MAINTAINED DUE TO EXISTING CONDITIONS, THE VARIATION ALLOWED IS THE WATER MAIN IN A SEPARATE TRENCH WITH THE ELEVATION OF THE WATER MAIN AT LEAST 18" ABOVE THE TOP OF THE SEWER & MUST BE APPROVED BY THE PUBLIC UTILITIES DIRECTOR. ALL DISTANCES ARE MEASURED FROM OUTSIDE DIAMETER TO OUTSIDE DIAMETER.
  - c. WHERE IT IS IMPOSSIBLE TO OBTAIN PROPER SEPARATION, OR ANYTIME A SANITARY SEWER PASSES OVER A WATERMAIN, DIP MATERIALS OR STEEL ENCASEMENT EXTENDED 10' ON EACH SIDE OF CROSSING MUST BE SPECIFIED & INSTALLED TO WATERLINE SPECIFICATIONS.
  - d. 5.0' MINIMUM HORIZONTAL SEPARATION IS REQUIRED BETWEEN ALL SANITARY SEWER & STORM SEWER FACILITIES, UNLESS DIP MATERIAL IS SPECIFIED FOR SANITARY SEWER.
  - e. MAINTAIN 18" MIN. VERTICAL SEPARATION AT ALL WATERMAIN & RCP STORM DRAIN CROSSINGS; MAINTAIN 18" MIN. VERTICAL SEPARATION AT ALL SANITARY SEWER & RCP STORM DRAIN CROSSINGS, WHERE ADEQUATE SEPARATIONS CANNOT BE ACHIEVED, SPECIFY DIP MATERIALS & A CONCRETE CRADLE HAVING 6" MIN. CLEARANCE (PER CORPUD DETAILS W-41 & 5-49).
  - f. ALL OTHER UNDERGROUND UTILITIES SHALL CROSS WATER & SEWER FACILITIES WITH 18" MIN. VERTICAL SEPARATION REQUIRED.
3. ANY NECESSARY FIELD REVISIONS ARE SUBJECT TO REVIEW & APPROVAL OF AN AMENDED PLAN &/OR PROFILE BY THE CITY OF RALEIGH PUBLIC UTILITIES DEPARTMENT PRIOR TO CONSTRUCTION.
4. CONTRACTOR SHALL MAINTAIN CONTINUOUS WATER & SEWER SERVICE TO EXISTING RESIDENCES & BUSINESSES THROUGHOUT CONSTRUCTION OF PROJECT. ANY NECESSARY SERVICE INTERRUPTIONS SHALL BE PRECEDED BY A 24 HOUR ADVANCE NOTICE TO THE CITY OF RALEIGH PUBLIC UTILITIES DEPARTMENT.
5. 3.0' MINIMUM COVER IS REQUIRED ON ALL WATER MAINS & SEWER FORCEMAINS. 4.0' MINIMUM COVER IS REQUIRED ON ALL REUSE MAINS.
6. IT IS THE DEVELOPER'S RESPONSIBILITY TO ABANDON OR REMOVE EXISTING WATER & SEWER SERVICES NOT BEING USED IN REDEVELOPMENT OF A SITE UNLESS OTHERWISE DIRECTED BY THE CITY OF RALEIGH PUBLIC UTILITIES DEPARTMENT. THIS INCLUDES ABANDONING TAP AT MAIN & REMOVAL OF SERVICE FROM ROW OR EASEMENT PER CORPUD HANDBOOK PROCEDURE.
7. INSTALL 3/4" COPPER WATER SERVICES WITH METERS LOCATED AT ROW OR WITHIN A 2'X2' WATERLINE EASEMENT IMMEDIATELY ADJACENT. NOTE: IT IS THE APPLICANT'S RESPONSIBILITY TO PROPERLY SIZE THE WATER SERVICE FOR EACH CONNECTION TO PROVIDE ADEQUATE FLOW & PRESSURE.
8. INSTALL 4" PVC SEWER SERVICES @ 1.0% MINIMUM GRADE WITH CLEANOUTS LOCATED AT ROW OR EASEMENT LINE & SPACED EVERY 75 LINEAR FEET MAXIMUM.
9. PRESSURE REDUCING VALVES ARE REQUIRED ON ALL WATER SERVICES EXCEEDING 80 PSI; BACKWATER VALVES ARE REQUIRED ON ALL SANITARY SEWER SERVICES HAVING BUILDING DRAINS LOWER THAN 1.0' ABOVE THE NEXT UPSTREAM MANHOLE.
10. ALL ENVIRONMENTAL PERMITS APPLICABLE TO THE PROJECT MUST BE OBTAINED FROM NCDM, USACE &/OR FEMA FOR ANY RIPARIAN BUFFER, WETLAND &/OR FLOODPLAIN IMPACTS (RESPECTIVELY) PRIOR TO CONSTRUCTION.
11. NCDOT / RAILROAD ENCROACHMENT AGREEMENTS ARE REQUIRED FOR ANY UTILITY WORK (INCLUDING MAIN EXTENSIONS & SERVICE TAPS) WITHIN STATE OR RAILROAD ROW PRIOR TO CONSTRUCTION.
12. GREASE INTERCEPTOR / OIL WATER SEPARATOR SIZING CALCULATIONS & INSTALLATION SPECIFICATIONS SHALL BE APPROVED BY THE CORPUD FOG PROGRAM COORDINATOR PRIOR TO ISSUANCE OF A BUILDING PERMIT. CONTACT TIM BEASLEY AT (919) 996-2334 OR TIMOTHY.BEASLEY@RALEIGHNC.GOV FOR MORE INFORMATION.
13. CROSS-CONNECTION CONTROL PROTECTION DEVICES ARE REQUIRED BASED ON DEGREE OF HEALTH HAZARD INVOLVED AS LISTED IN APPENDIX-B OF THE RULES GOVERNING PUBLIC WATER SYSTEMS IN NORTH CAROLINA. THESE GUIDELINES ARE THE MINIMUM REQUIREMENTS. THE DEVICES SHALL MEET AMERICAN SOCIETY OF SANITARY ENGINEERING (ASSE) STANDARDS OR BE ON THE UNIVERSITY OF SOUTHERN CALIFORNIA APPROVAL LIST. THE DEVICES SHALL BE INSTALLED AND TESTED (BOTH INITIAL AND PERIODIC TESTING THEREAFTER) IN ACCORDANCE WITH THE MANUFACTURER'S RECOMMENDATIONS OR THE LOCAL CROSS-CONNECTION CONTROL PROGRAM, WHICHEVER IS MORE STRINGENT. CONTACT JOANIE HARTLEY AT (919) 996-5923 OR JOANIE.HARTLEY@RALEIGHNC.GOV FOR MORE INFORMATION.

**NOTES:**

DEEDS OF EASEMENT FOR SANITARY SEWER PURPOSES TO CITY OF RALEIGH RECORDED IN BOOK 12249, PAGE 864 AND BOOK 12466, PAGE 1149 AND AS SHOWN ON RECORDED PLAT IN BOOK OF MAPS 2006, PAGES 2216 AND 2217, WAKE COUNTY REGISTRY.

(DEED OF EASEMENT SUPERSEDED BY BM 2008 PG 480 & 481)

RIGHT OF WAY AND UTILITY EASEMENTS RECORDED IN BOOK 13736, PAGES 1287 AND 1294 AND AS SHOWN ON RECORDED PLAT IN BOOK OF MAPS 2009, PAGE 1091, WAKE COUNTY REGISTRY.

(AS SHOWN ON SURVEY)

DEEDS OF EASEMENT FOR SANITARY SEWER PURPOSES TO CITY OF RALEIGH RECORDED IN BOOK 12249, PAGE 860 AND BOOK 12466, PAGE 1171 AND AS SHOWN ON RECORDED PLAT IN BOOK OF MAPS 2006, PAGES 2216 AND 2217, WAKE COUNTY REGISTRY.

**BY-PASS PUMPING NOTES**

- ALL
1. DEVELOPER SHALL PROVIDE 30 DAYS ADVANCE WRITTEN NOTICE TO PROPERTY OWNER FOR ANY WORK REQUIRED WITHIN AN EXISTING CITY OF RALEIGH UTILITY EASEMENT TRAVERSING PRIVATE PROPERTY.
  2. A BYPASS PLAN SEALED BY A NC PROFESSIONAL ENGINEER MUST BE SUBMITTED TO CITY OF RALEIGH PUBLIC UTILITIES PRIOR TO PUMPING OPERATIONS TO COORDINATE WITH ENGINEERING STAFF. PUMPS SHOULD BE SIZED TO HANDLE THE PEAK FLOW(2.5 TIMES THE AVERAGE DAILY FLOW) FOR THE LINE OR AREA OF WORK. THE CONTRACTOR SHALL SECURE THE PUMPS FROM A PUMP SUPPLIER ACCORDING TO THE PROVIDED FLOW INFORMATION. PUMPING OPERATIONS MUST BE MONITORED 24 HOURS A DAY FOR EACH OF THE PUMPING OPERATION BY QUALIFIED PERSONNEL IN ORDER TO RESPOND TO PROBLEMS OR FAILURES. 100% REDUNDANCY IS REQUIRED FOR PUMPING OPERATIONS. IN ADDITION, BACK UP PUMPS ARE TO BE CONNECTED TO THE BYPASS FORCE MAIN TO FACILITATE IMMEDIATE USE UPON FAILURE OF THE PRIMARY PUMPS.

**SITE PERMITTING APPROVAL**

**Water and Sewer Permits (if applicable)**

The City of Raleigh consents to the connection and extension of the City's Public Sewer System as shown on this plan. The material and Construction methods used for this project shall conform to the standards and specifications of the City's Public Utilities Handbook, City of Raleigh Public Utilities Department Permit # \_\_\_\_\_

The City of Raleigh consents to the connection and extension of the City's Public Water System as shown on this plan. The material and Construction methods used for this project shall conform to the standards and specifications of the City's Public Utilities Handbook, City of Raleigh Public Utilities Department Permit # \_\_\_\_\_

The City of Raleigh consents to the connection to its public sewer system and extension of the private sewer collection system as shown on this plan. The material and constructions methods used for this project shall conform to the standards and specifications of the City's Public Utilities Handbook.  
City of Raleigh Public Utilities Department Permit # \_\_\_\_\_

**CITY OF RALEIGH – PLANS AUTHORIZED FOR CONSTRUCTION**

Plans for the proposed use have been reviewed for general compliance with applicable codes. This limited review, and authorization for construction is not to be considered to represent total compliance with all legal requirements for development and construction. The property owner, design consultants, and contractors are each responsible for compliance with all applicable City, State and Federal laws. This specific authorization below is not a permit, nor shall it be construed to permit any violation of City, State or Federal Law. All Construction must be in accordance with all Local, State, and Federal Rules and Regulations.

Electronic Approval: This approval is being issued electronically. This approval is valid only upon the signature of a City of Raleigh Review Officer below. The City will retain a copy of the approved plans. Any work authorized by this approval must proceed in accordance with the plans kept on file with the City. This electronic approval may not be edited once issued. Any modification to this approval once issued will invalidate this approval.

City of Raleigh Development Approval \_\_\_\_\_  
City of Raleigh Review Officer

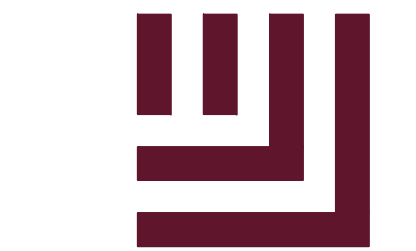

**McADAMS**

The John R. McAdams Company, Inc.  
2905 Meridian Parkway  
Durham, NC 27713

phone 919. 361. 5000  
fax 919. 361. 2269  
license number: C-0293, C-187

www.mcadamsco.com

**CLIENT**

ASHTON RALEIGH RESIDENTIAL, LLC.  
5711 SIX FORKS ROAD, SUITE 300  
RALEIGH, NORTH CAROLINA 27609  
PHONE: 919. 232. 3695  
CONTACT: BOB MISHLER

\\Images\Ashton Woods logo.jpg

**HARRIS CREEK INTERCEPTOR  
IMPROVEMENTS**  
TOWN OF ROLESVILLE, WAKE FOREST TOWNSHIP,  
WAKE COUNTY, NORTH CAROLINA



**REVISIONS**

NO. DATE

**PLAN INFORMATION**

PROJECT NO. AWH-20000  
FILENAME AWH20000-N1  
CHECKED BY .  
DRAWN BY .  
SCALE N.T.S.  
DATE 10.12.2021

**SHEET**

**PROJECT NOTES**

**CO.00**

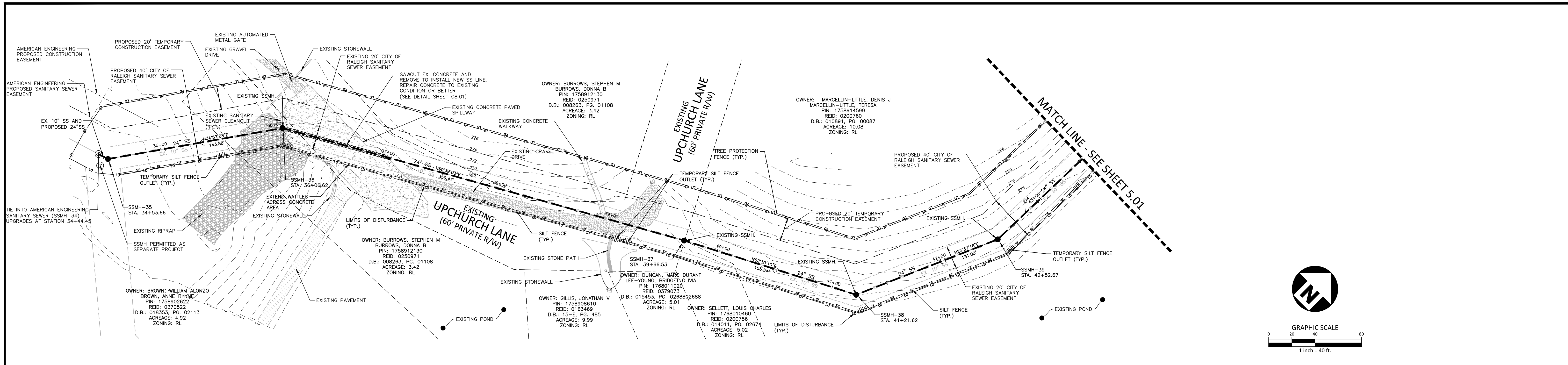

# HARRIS CREEK INTERCEPTOR

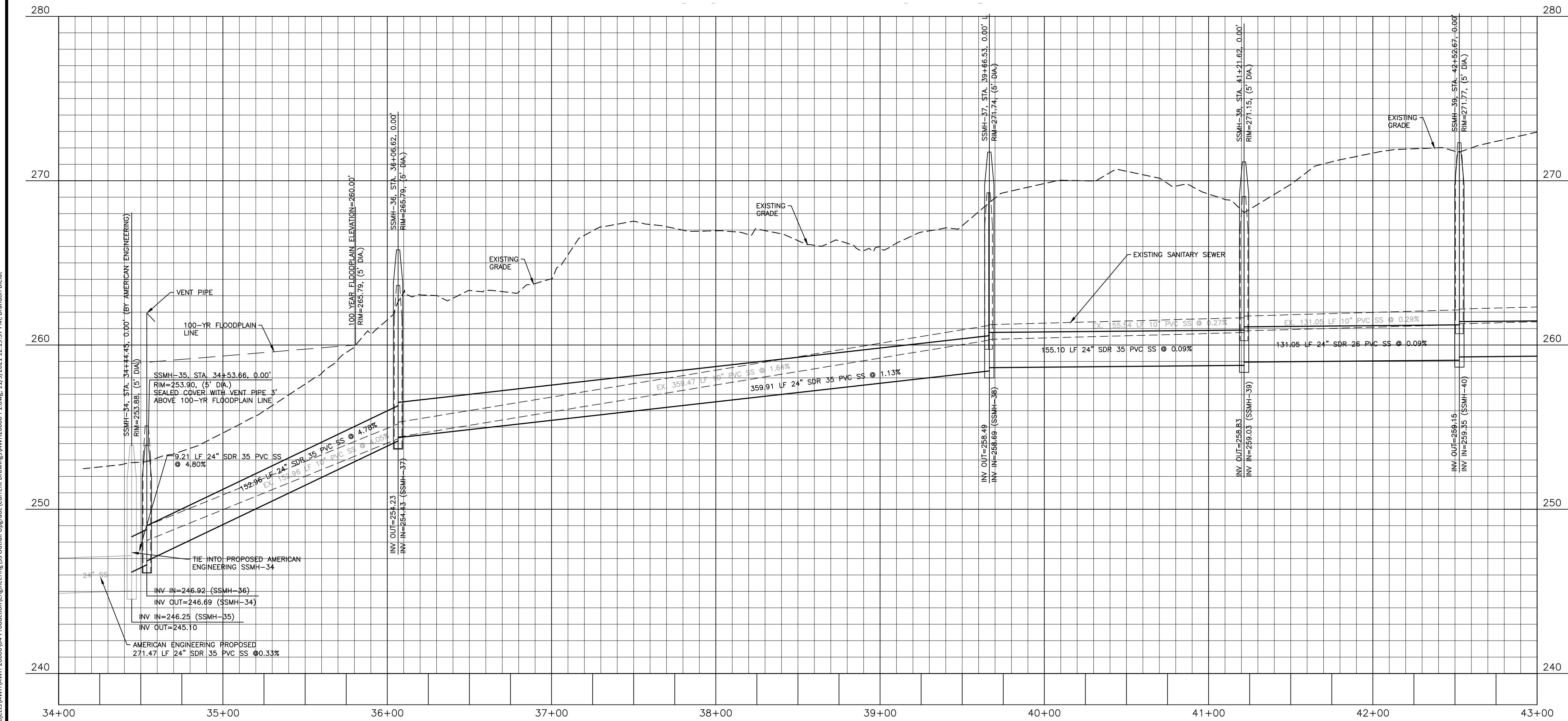

**SITE PERMITTING APPROVAL**

**Water and Sewer Permits (if applicable)**

The City of Raleigh consents to the connection and extension of the City's Public Sewer System as shown on this plan. The material and construction methods used for this project shall conform to the standards and specifications of the City's Public Utilities Handbook, City of Raleigh Public Utilities Department Permit # \_\_\_\_\_.

The City of Raleigh consents to the connection and extension of the City's Public Water System as shown on this plan. The material and construction methods used for this project shall conform to the standards and specifications of the City's Public Utilities Handbook, City of Raleigh Public Utilities Department Permit # \_\_\_\_\_.

The City of Raleigh consents to the connection to its public sewer system and extension of the private sewer collection system as shown on this plan. The material and construction methods used for this project shall conform to the standards and specifications of the City's Public Utilities Handbook, City of Raleigh Public Utilities Department Permit # \_\_\_\_\_.

**CITY OF RALEIGH - PLANS AUTHORIZED FOR CONSTRUCTION**

Plans for the proposed use have been reviewed for general compliance with applicable codes. This limited review, and authorization for construction is not to be considered to represent total compliance with all legal requirements for development and construction. The property owner, design consultants, and contractors are each responsible for compliance with all applicable City, State and Federal laws. This specific authorization below is not a permit, nor shall it be construed to permit any violation of City, State or Federal Law. All construction must be in accordance with all Local, State, and Federal Rules and Regulations.

Electronic Approval: This approval is being issued electronically. This approval is valid only upon the signature of a City of Raleigh Review Officer below. The City will retain a copy of the approved plans. Any work authorized by this approval must proceed in accordance with the plans kept on file with the City. This electronic approval may not be edited once issued. Any modification to this approval once issued will invalidate this approval.

City of Raleigh Development Approval \_\_\_\_\_  
 City of Raleigh Review Officer \_\_\_\_\_

The John R. McAdams Company, Inc.  
 2905 Meridian Parkway  
 Durham, NC 27713

phone 919. 361. 5000  
 fax 919. 361. 2269  
 license number: C-0293, C-187

www.mcadamsco.com

**CLIENT**

NAME \_\_\_\_\_  
 ADDRESS \_\_\_\_\_  
 ADDRESS \_\_\_\_\_  
 PHONE: XXX. XXX. XXXX

**REVISIONS**

NO.	DATE	REVISION DESCRIPTION
1	XX.XX.XXXX	REVISION DESCRIPTION
2	XX.XX.XXXX	REVISION DESCRIPTION

## HARRIS CREEK INTERCEPTOR IMPROVEMENTS

### CONSTRUCTION DRAWINGS

TOWN OF ROLESVILLE, WAKE FOREST TOWNSHIP,  
 WAKE COUNTY, NORTH CAROLINA

**PLAN INFORMATION**

PROJECT NO. AWH20000  
 FILENAME AWH20000-P1  
 CHECKED BY WTO  
 DRAWN BY BB  
 SCALE 1"=40'/1"=4'  
 DATE 10.12.2021

**PLAN AND PROFILE**  
 HARRIS CREEK INTERCEPTOR  
 STA. 34+00 THRU STA. 43+00

# C5.00

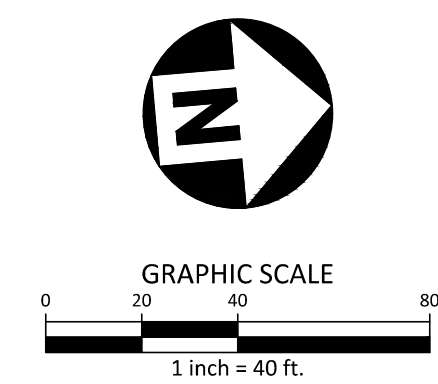
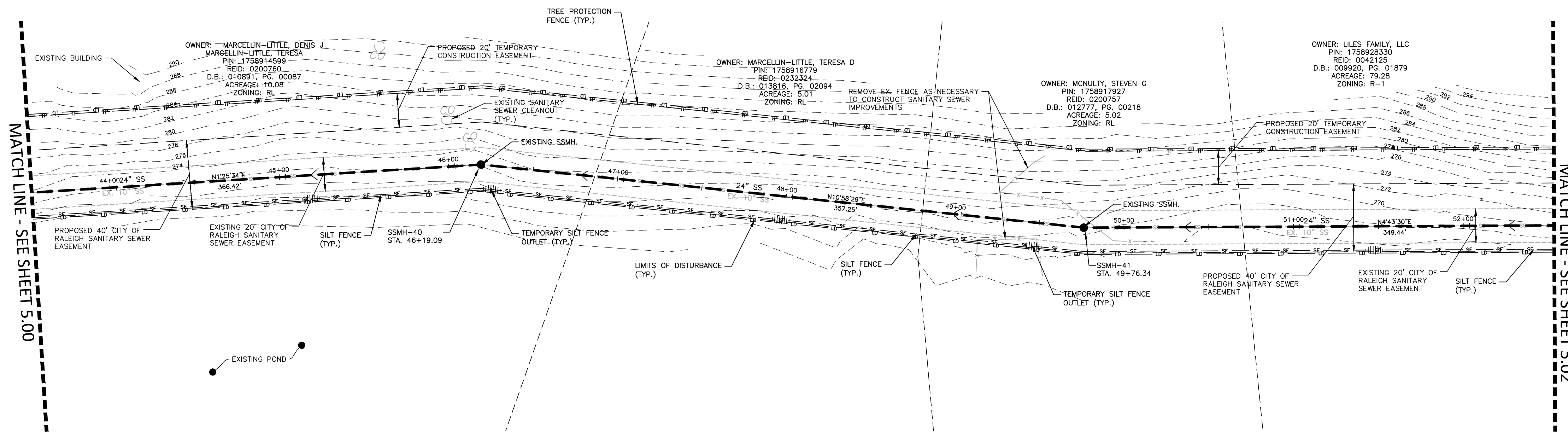

# HARRIS CREEK INTERCEPTOR

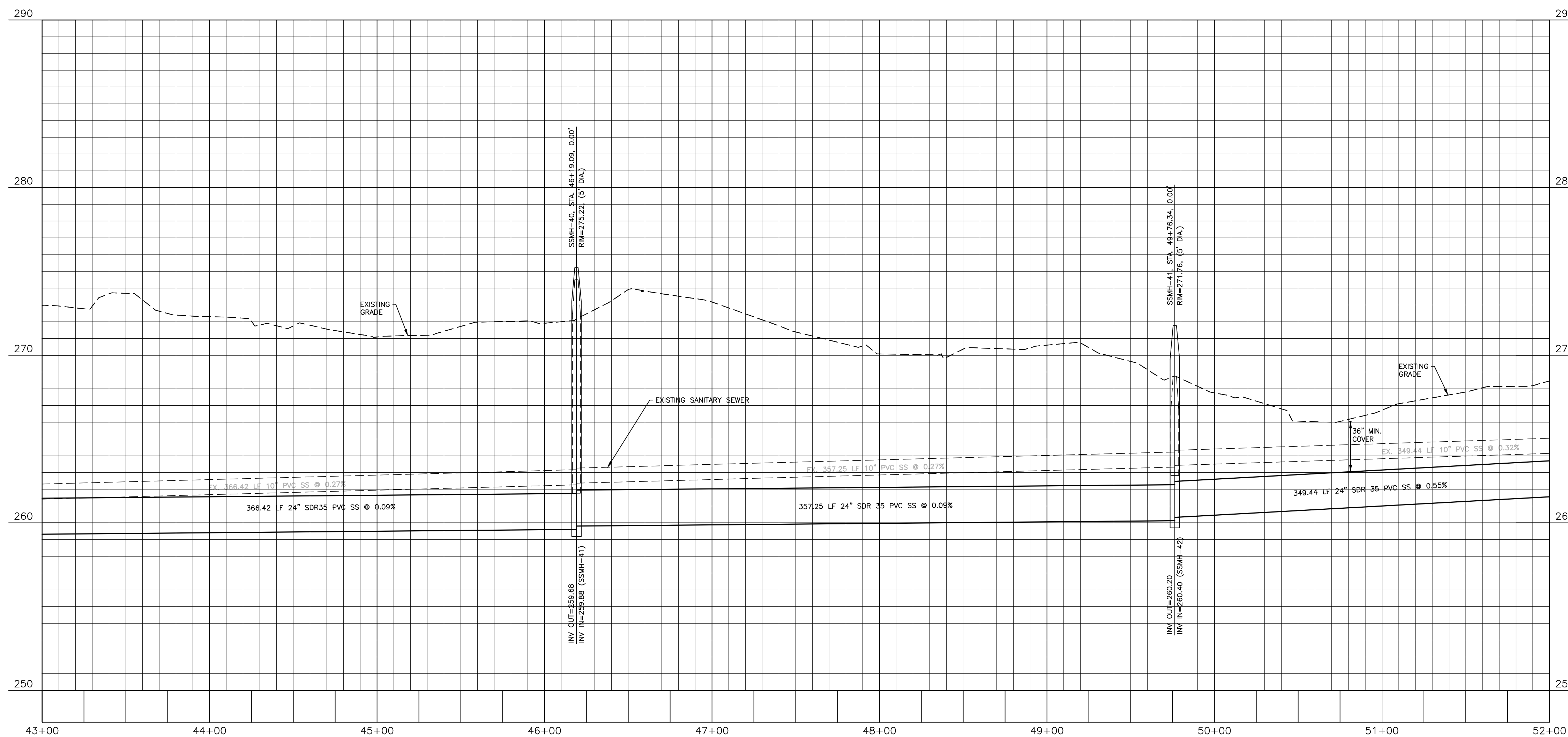

**SITE PERMITTING APPROVAL**

**Water and Sewer Permits (if applicable)**

The City of Raleigh consents to the connection and extension of the City's Public Sewer System as shown on this plan. The material and Construction methods used for this project shall conform to the standards and specifications of the City's Public Utilities Handbook, City of Raleigh Public Utilities Department Permit # \_\_\_\_\_.

The City of Raleigh consents to the connection and extension of the City's Public Water System as shown on this plan. The material and Construction methods used for this project shall conform to the standards and specifications of the City's Public Utilities Handbook, City of Raleigh Public Utilities Department Permit # \_\_\_\_\_.

The City of Raleigh consents to the connection and extension of the private sewer collection system as shown on this plan. The material and construction methods used for this project shall conform to the standards and specifications of the City's Public Utilities Handbook, City of Raleigh Public Utilities Department Permit # \_\_\_\_\_.

**CITY OF RALEIGH - PLANS AUTHORIZED FOR CONSTRUCTION**

Plans for the proposed use have been reviewed for general compliance with applicable codes. This limited review, and authorization for construction is not to be considered to represent total compliance with all legal requirements for development and construction. The property owner, design consultants, and contractors are each responsible for compliance with all applicable City, State and Federal laws. This specific authorization below is not a permit, nor shall it be construed to permit any violation of City, State or Federal Law. All Construction must be in accordance with all Local, State, and Federal Rules and Regulations.

Electronic Approval: This approval is being issued electronically. This approval is valid only upon the signature of a City of Raleigh Review Officer below. The City will retain a copy of the approved plans. Any work authorized by this approval must proceed in accordance with the plans kept on file with the City. This electronic approval may not be edited once issued. Any modification to this approval once issued will invalidate this approval.

City of Raleigh Development Approval \_\_\_\_\_  
 City of Raleigh Review Officer \_\_\_\_\_

M:\Projects\AWH\AWH20000\Production\Engineering\SS-Cut\fill\Upgrade\Current Drawings\AWH20000-PS.dwg, 11/5/2021 12:21:36 PM, Brandon Bledsoe



The John R. McAdams Company, Inc.  
 2905 Meridian Parkway  
 Durham, NC 27713

phone 919. 361. 5000  
 fax 919. 361. 2269  
 license number: C-0293, C-187

www.mcadamsco.com

**CLIENT**

NAME  
 ADDRESS  
 ADDRESS  
 PHONE: XXX. XXX. XXXX

**REVISIONS**

NO.	DATE	REVISION DESCRIPTION
1	XX.XX.XXXX	REVISION DESCRIPTION
2	XX.XX.XXXX	REVISION DESCRIPTION



## HARRIS CREEK INTERCEPTOR IMPROVEMENTS

### CONSTRUCTION DRAWINGS

TOWN OF ROLESVILLE, WAKE FOREST TOWNSHIP,  
 WAKE COUNTY, NORTH CAROLINA

**PLAN INFORMATION**

PROJECT NO.	AWH20000
FILENAME	AWH20000-PS
CHECKED BY	WTO
DRAWN BY	BB
SCALE	1"=40'/1"=4'
DATE	10. 12. 2021

**PLAN AND PROFILE**  
 HARRIS CREEK INTERCEPTOR  
 STA. 43+00 THRU STA. 52+00

# C5.01

FINAL DRAWING - NOT RELEASED FOR CONSTRUCTION

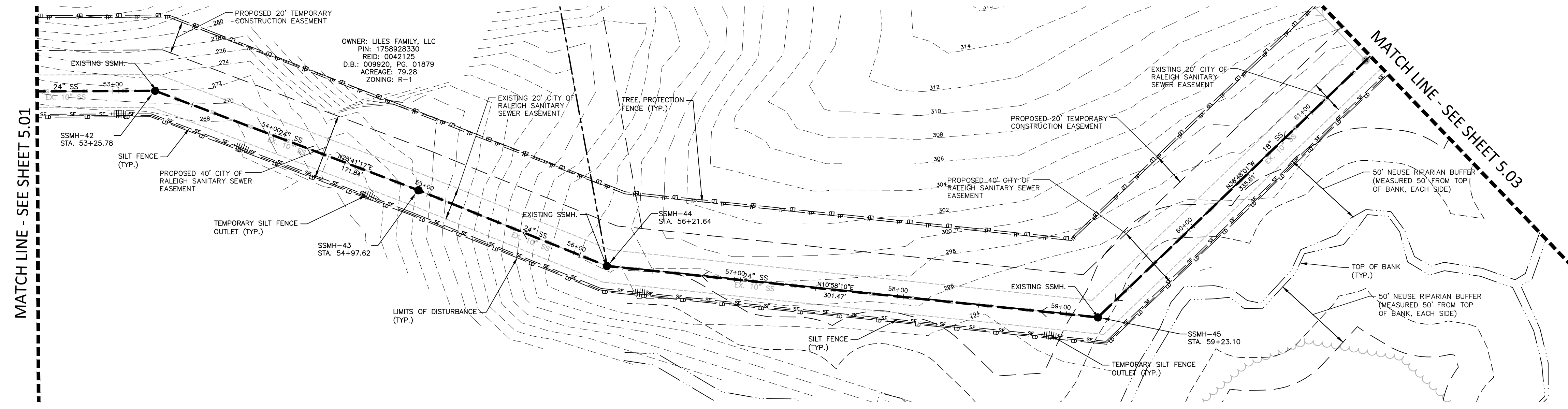

## HARRIS CREEK INTERCEPTOR

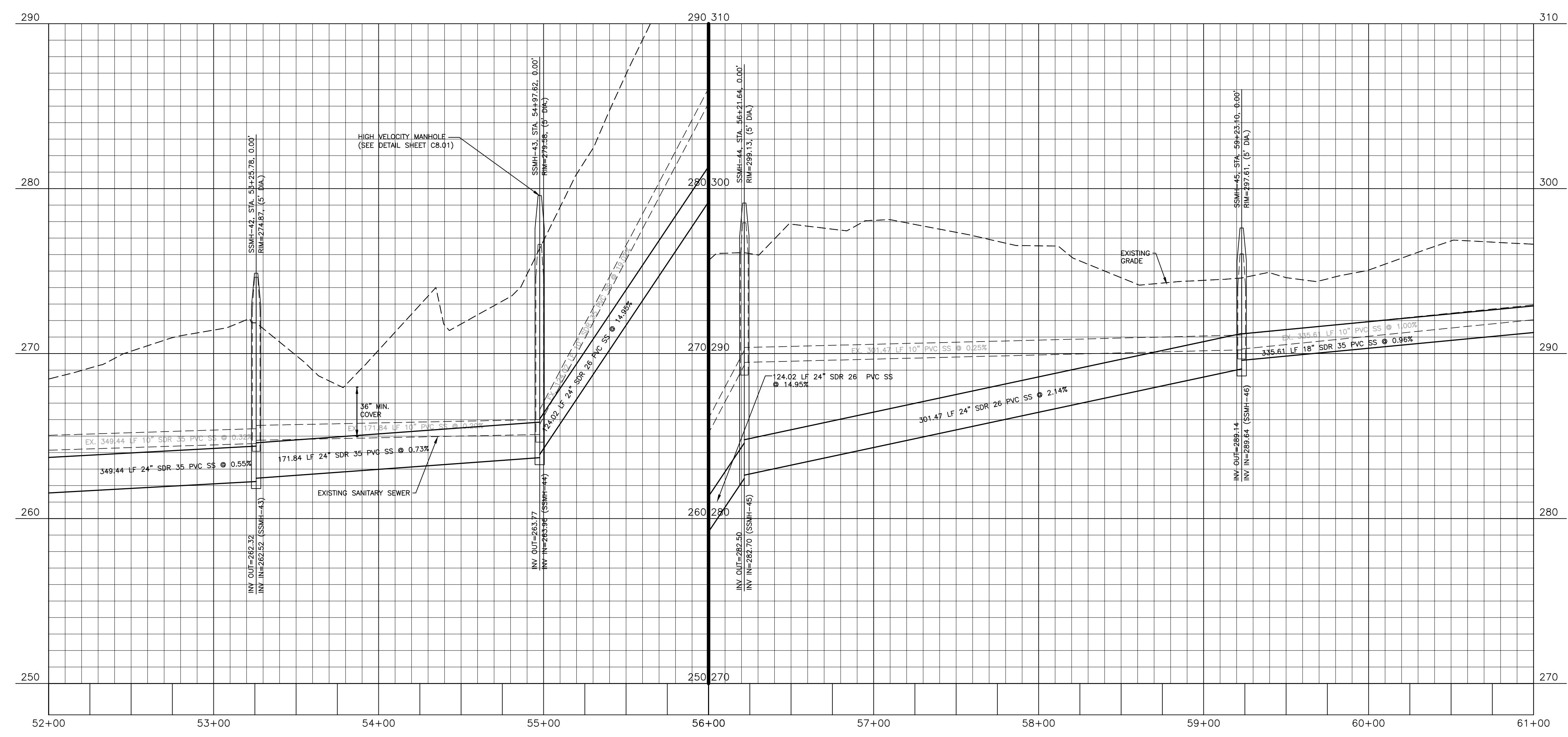

**SITE PERMITTING APPROVAL**

**Water and Sewer Permits (if applicable)**

The City of Raleigh consents to the connection and extension of the City's Public Sewer System as shown on this plan. The material and Construction methods used for this project shall conform to the standards and specifications of the City's Public Utilities Handbook, City of Raleigh Public Utilities Department Permit # \_\_\_\_\_.

The City of Raleigh consents to the connection and extension of the City's Public Water System as shown on this plan. The material and Construction methods used for this project shall conform to the standards and specifications of the City's Public Utilities Handbook, City of Raleigh Public Utilities Department Permit # \_\_\_\_\_.

The City of Raleigh consents to the connection to its public sewer system and extension of the private sewer collection system as shown on this plan. The material and construction methods used for this project shall conform to the standards and specifications of the City's Public Utilities Handbook, City of Raleigh Public Utilities Department Permit # \_\_\_\_\_.

**CITY OF RALEIGH - PLANS AUTHORIZED FOR CONSTRUCTION**

Plans for the proposed use have been reviewed for general compliance with applicable codes. This limited review, and authorization for construction is not to be considered to represent total compliance with all legal requirements for development and construction. The property owner, design consultants, and contractors are each responsible for compliance with all applicable City, State and Federal laws. This specific authorization below is not a permit, nor shall it be construed to permit any violation of City, State or Federal Law. All Construction must be in accordance with all Local, State, and Federal Rules and Regulations.

Electronic Approval: This approval is being issued electronically. This approval is valid only upon the signature of a City of Raleigh Review Officer below. The City will retain a copy of the approved plans. Any work authorized by this approval must proceed in accordance with the plans kept on file with the City. This electronic approval may not be relied upon if issued. Any modification to this approval once issued will invalidate this approval.

City of Raleigh Development Approval \_\_\_\_\_  
 City of Raleigh Review Officer \_\_\_\_\_

M:\Projects\AWH\20000\AWH20000\Production\Engineering\SS\Outfall Upgrade\Current Drawings\AWH20000-P1.dwg, 11/5/2021 12:22:46 PM, Brandon Bialik

The John R. McAdams Company, Inc.  
 2905 Meridian Parkway  
 Durham, NC 27713

phone 919. 361. 5000  
 fax 919. 361. 2269  
 license number: C-0293, C-187

www.mcadamsco.com

**CLIENT**

NAME  
 ADDRESS  
 ADDRESS  
 PHONE: XXX. XXX. XXXX

**REVISIONS**

NO.	DATE	REVISION DESCRIPTION
1	XX. XX. XXXX	REVISION DESCRIPTION
2	XX. XX. XXXX	REVISION DESCRIPTION



### HARRIS CREEK INTERCEPTOR IMPROVEMENTS

CONSTRUCTION DRAWINGS  
 TOWN OF ROLESVILLE, WAKE FOREST TOWNSHIP,  
 WAKE COUNTY, NORTH CAROLINA

**PLAN INFORMATION**

PROJECT NO.	AWH20000
FILENAME	AWH20000-P1
CHECKED BY	WTO
DRAWN BY	BB
SCALE	1"=40'/1"=4'
DATE	10. 12. 2021

**PLAN AND PROFILE**  
 HARRIS CREEK INTERCEPTOR  
 STA. 52+00 THRU STA. 61+00

# C5.02

FINAL DRAWING - NOT RELEASED FOR CONSTRUCTION

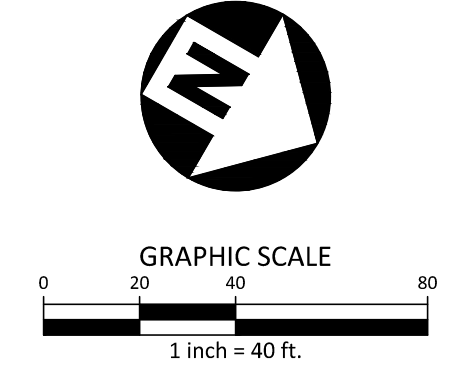
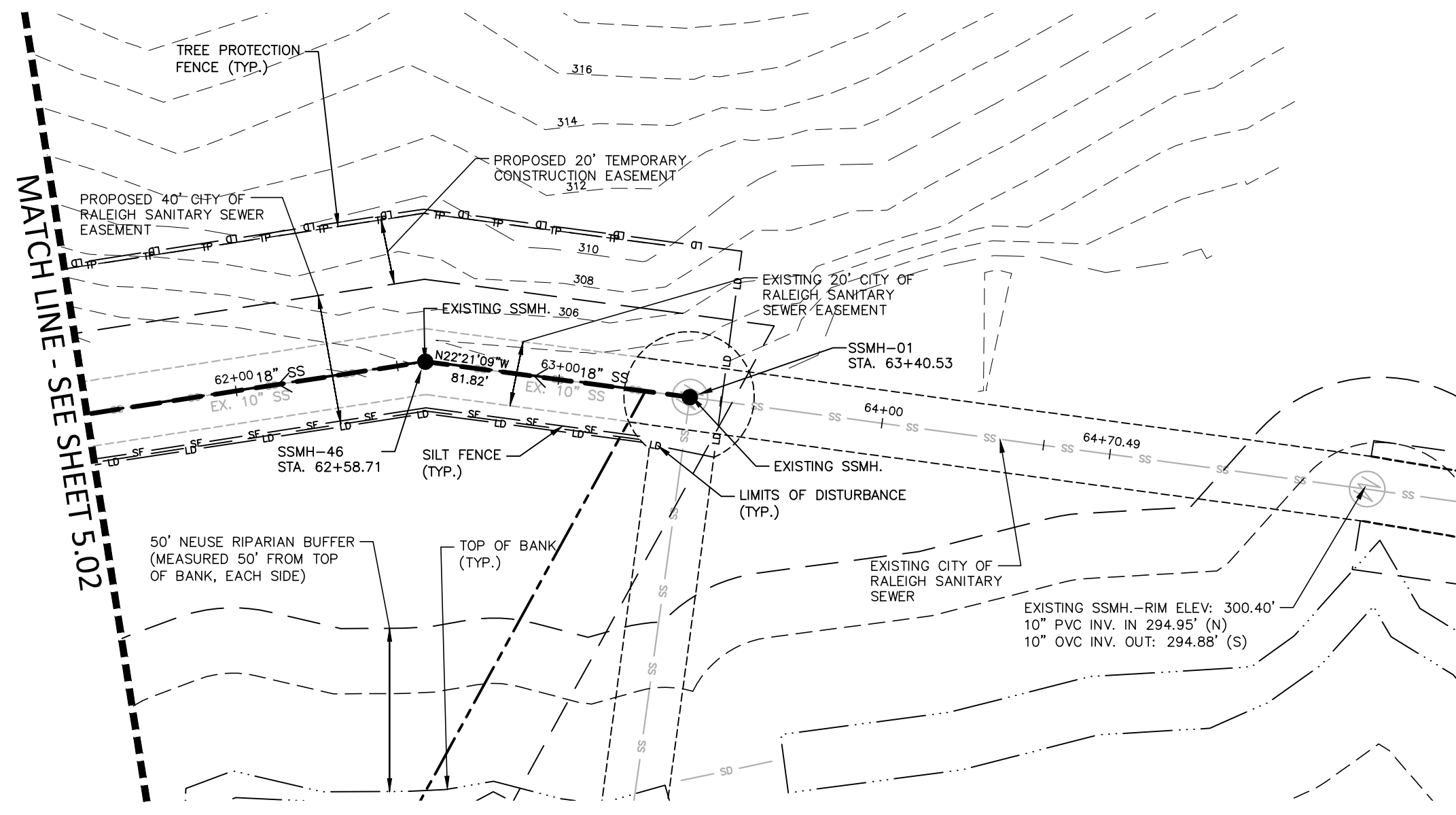

## HARRIS CREEK INTERCEPTOR

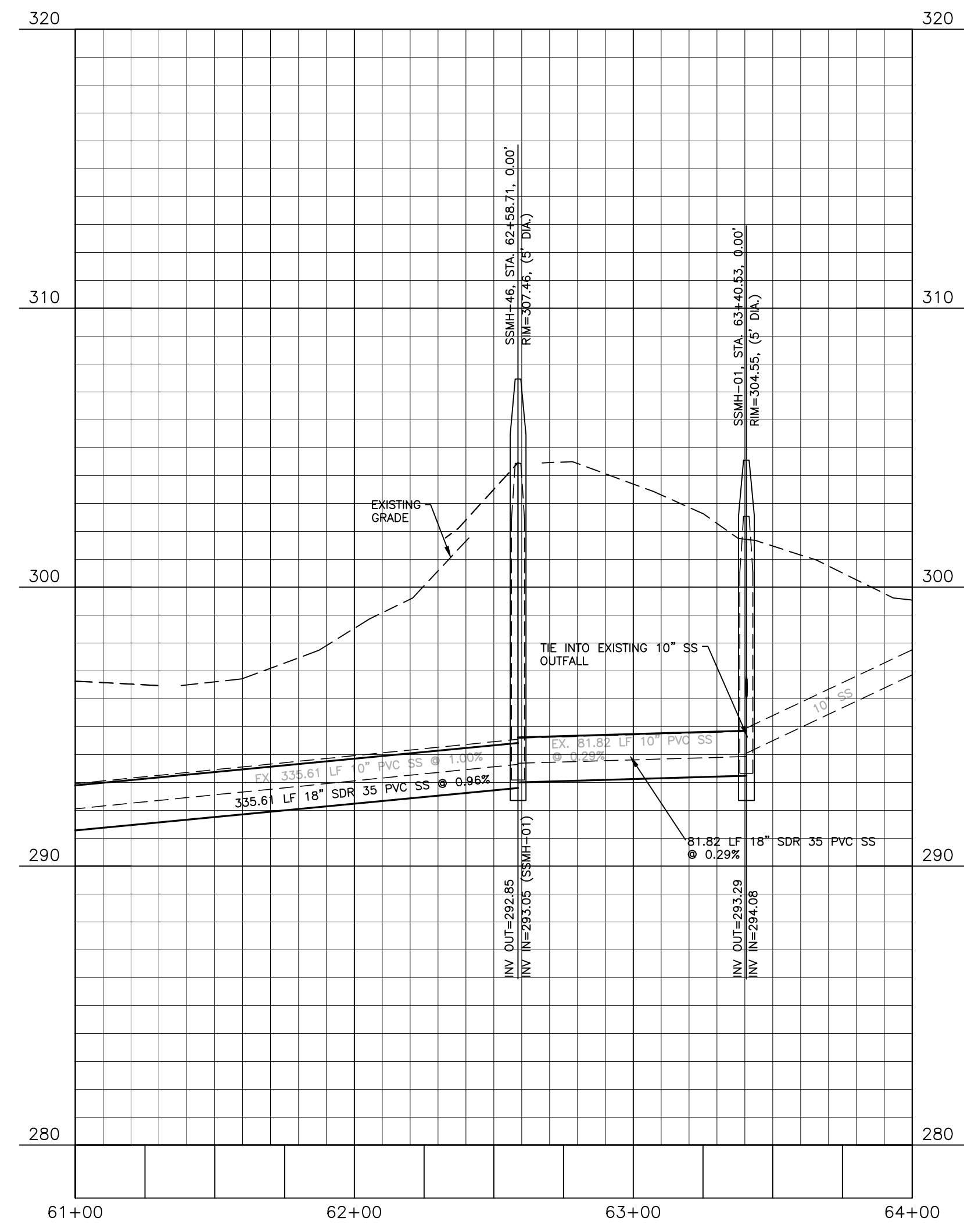

### SITE PERMITTING APPROVAL

**Water and Sewer Permits (if applicable)**

The City of Raleigh consents to the connection and extension of the City's Public Sewer System as shown on this plan. The material and Construction methods used for this project shall conform to the standards and specifications of the City's Public Utilities Handbook, City of Raleigh Public Utilities Department Permit # \_\_\_\_\_.

The City of Raleigh consents to the connection and extension of the City's Public Water System as shown on this plan. The material and Construction methods used for this project shall conform to the standards and specifications of the City's Public Utilities Handbook, City of Raleigh Public Utilities Department Permit # \_\_\_\_\_.

The City of Raleigh consents to the connection to its public sewer system and extension of the private sewer collection system as shown on this plan. The material and construction methods used for this project shall conform to the standards and specifications of the City's Public Utilities Handbook, City of Raleigh Public Utilities Department Permit # \_\_\_\_\_.

### CITY OF RALEIGH - PLANS AUTHORIZED FOR CONSTRUCTION

Plans for the proposed use have been reviewed for general compliance with applicable codes. This limited review, and authorization for construction is not to be considered to represent total compliance with all legal requirements for development and construction. The property owner, design consultants, and contractors are each responsible for compliance with all applicable City, State and Federal laws. This specific authorization below is not a permit, nor shall it be construed to permit any violation of City, State or Federal Law. All Construction must be in accordance with all Local, State, and Federal Rules and Regulations.

Electronic Approval: This approval is being issued electronically. This approval is valid only upon the signature of a City of Raleigh Review Officer below. The City will retain a copy of the approved plans. Any work authorized by this approval must proceed in accordance with the plans kept on file with the City. This electronic approval may not be edited once issued. Any modification to this approval once issued will invalidate this approval.

City of Raleigh Development Approval \_\_\_\_\_  
City of Raleigh Review Officer \_\_\_\_\_

FINAL DRAWING - NOT RELEASED FOR CONSTRUCTION

M:\Projects\AWH\AWH20000\Production\Engineering\SS-01.dwg (Upgrade)\Current Drawings\AWH20000-P1.dwg, 11/5/2021 12:22:22 PM, Brandon Bickel



The John R. McAdams Company, Inc.  
2905 Meridian Parkway  
Durham, NC 27713

phone 919. 361. 5000  
fax 919. 361. 2269  
license number: C-0293, C-187

www.mcadamsco.com

**CLIENT**  
NAME  
ADDRESS  
ADDRESS  
PHONE: XXX. XXX. XXXX

**REVISIONS**

NO.	DATE	REVISION DESCRIPTION
1	XX.XX.XXXX	REVISION DESCRIPTION
2	XX.XX.XXXX	REVISION DESCRIPTION

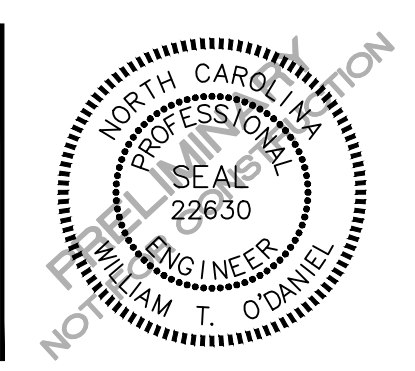

# HARRIS CREEK INTERCEPTOR IMPROVEMENTS

## CONSTRUCTION DRAWINGS

### TOWN OF ROLESVILLE, WAKE FOREST TOWNSHIP, WAKE COUNTY, NORTH CAROLINA

**PLAN INFORMATION**

PROJECT NO. AWH20000  
FILENAME AWH20000-P1  
CHECKED BY WTO  
DRAWN BY BB  
SCALE 1"=40'/1"=4'  
DATE 10. 12. 2021

**PLAN AND PROFILE**  
HARRIS CREEK INTERCEPTOR  
STA. 61+00 THRU STA. 64+00

# C5.03

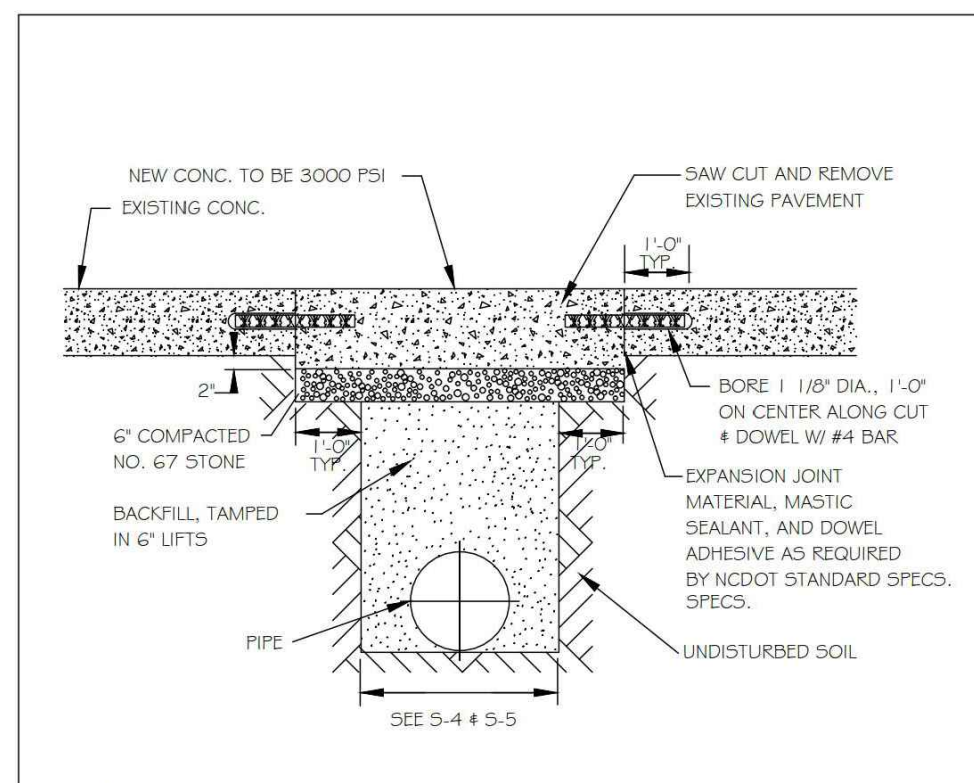

NOTES:  
 1. See City of Raleigh standards for trenches and pipe bedding (S-4 & S-5) for additional details.  
 2. Pavement cuts over 5'-0" in width shall be reinforced to N.C.D.O.T. standards.  
 3. Pavement cuts shall be made with an appropriate saw cut machine.  
 4. Pavement cuts when NCDOT ROW shall conform to the approved on site encroachment permit.

CITY OF RALEIGH DEPARTMENT OF PUBLIC UTILITIES STANDARD CONCRETE PAVEMENT PATCH DETAIL				
DWG. NO.	REVISIONS	DATE	REVISIONS	DATE
5-2	D.W.C. R.H.	6-23-99	A.B.B. J.F.S.	4-19-04 0-6-10

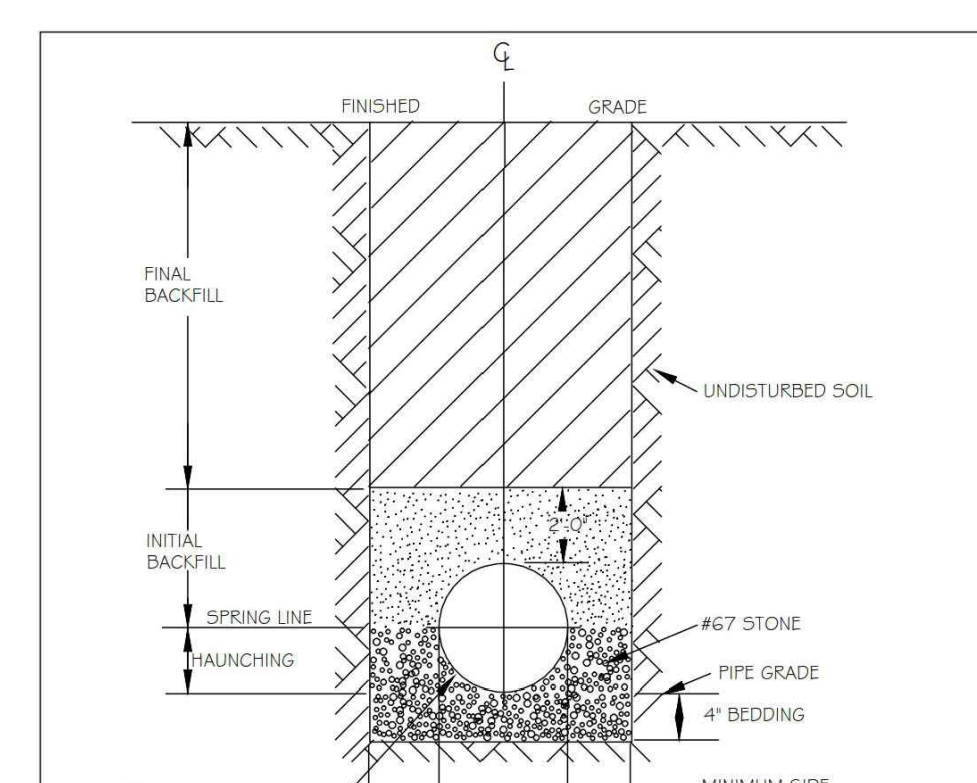

NOTES:  
 1. FOR TRENCHES REQUIRING SHORING AND BRACING, DIMENSIONS SHALL BE TAKEN FROM THE INSIDE FACE OF THE SHORING AND BRACING.  
 2. NO ROCKS OR BOULDERS 4" OR LARGER TO BE USED IN INITIAL BACKFILL.  
 3. ALL BACKFILL MATERIAL SHALL BE SUITABLE NATIVE MATERIAL.  
 4. BACKFILL SHALL BE TAMPED IN 6" LIFTS IN TRAFFIC AREAS, 12" IN NON-TRAFFIC AREAS.

CITY OF RALEIGH DEPARTMENT OF PUBLIC UTILITIES TRENCH BOTTOM DIMENSIONS AND BACKFILL REQUIREMENTS FOR PVC GRAVITY SEWER MAIN				
DWG. NO.	REVISIONS	DATE	REVISIONS	DATE
5-5	D.W.C. R.H.	3-1-97	A.B.B. R.H.	9-3-99 3-30-00

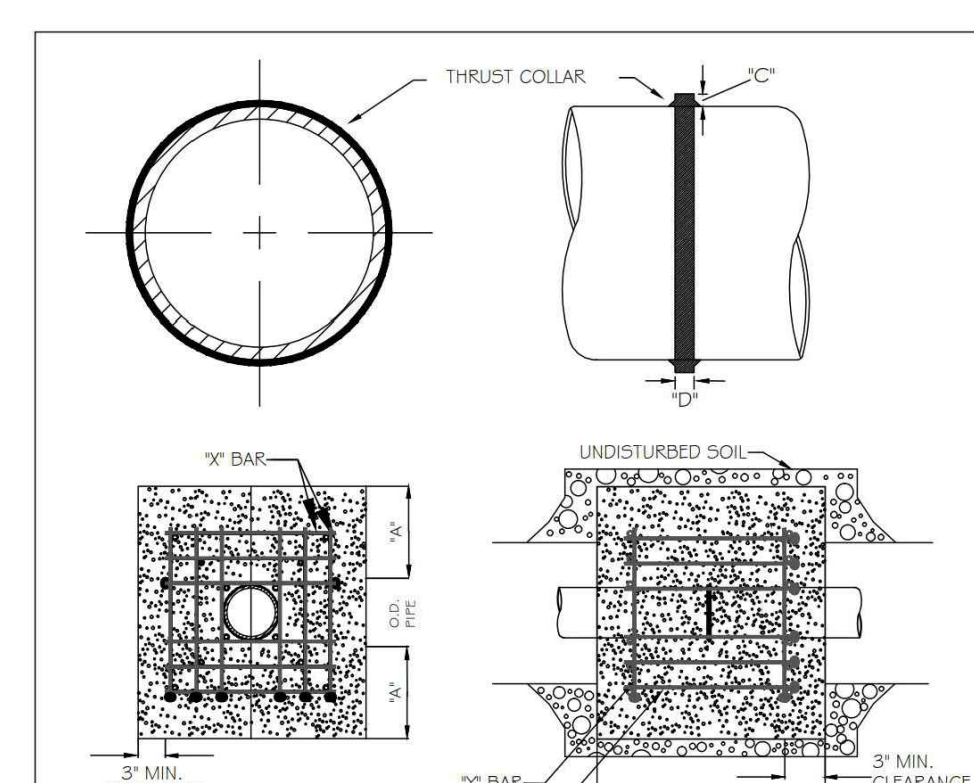

CITY OF RALEIGH DEPARTMENT OF PUBLIC UTILITIES RESTRAINING COLLAR DESIGN DATA FOR SEWER FORCE MAIN				
DWG. NO.	REVISIONS	DATE	REVISIONS	DATE
5-6	D.H.L.	1-21-00		6-18-05

NOTES:  
 1. CONCRETE SHALL BE 3000 PSI AND TRANSIT MIXED.  
 2. REINFORCING BARS SHALL BE DEFORMED AND TIED TOGETHER.  
 3. TRENCH BOTTOM WIDTH IN VICINITY OF THRUST BLOCK INSTALLATION SHALL BE THE MINIMUM WIDTH AS SHOWN ON STANDARD DETAIL W-5.  
 4. BACKFILL TAMPED IN 6" LIFTS PER STANDARD DETAIL W-5.  
 5. THRUST COLLAR MUST BE FACTORY WELDED ON BOTH SIDES ALONG BOTH EDGES OF COLLAR AROUND CIRCUMFERENCE.

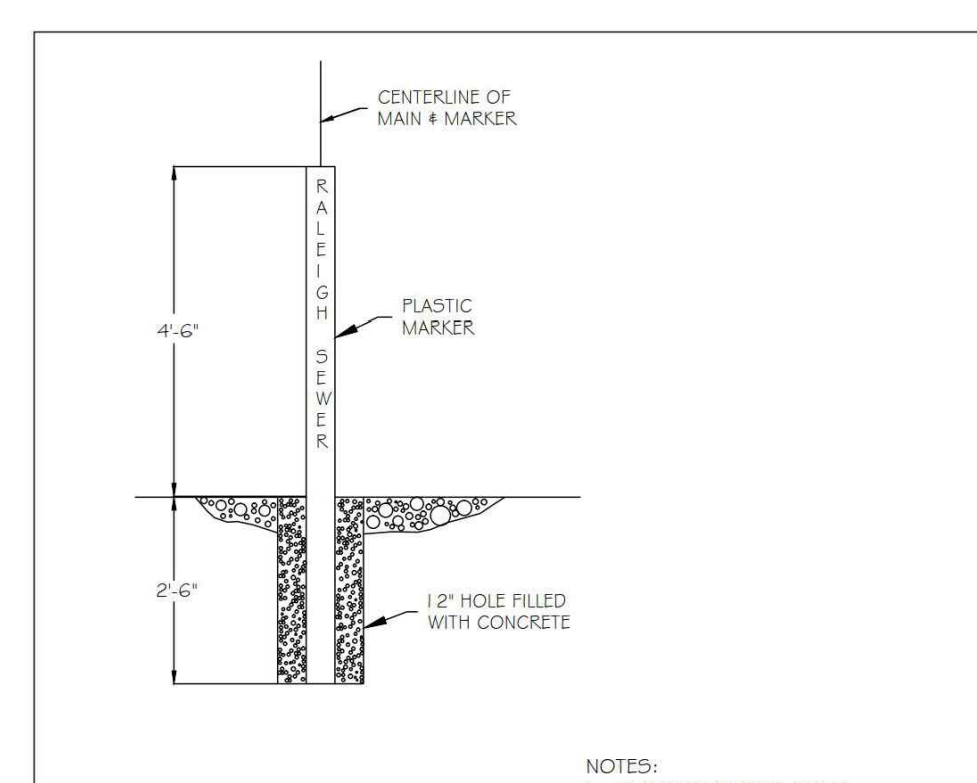

NOTES:  
 1. PLASTIC MARKER SHALL BE GREEN IN COLOR.  
 2. MARKERS SHALL BE LABELED "RALEIGH SEWER".  
 3. TO BE SPACED EVERY 300 FEET ON EACH SIDE OF ANY ROADWAY OR JUNCTION.  
 4. MARKERS SHALL BE ROUND 4" IN DIAMETER.

CITY OF RALEIGH DEPARTMENT OF PUBLIC UTILITIES STANDARD MAIN MARKER FOR SEWER FORCE MAINS IN EASEMENTS				
DWG. NO.	REVISIONS	DATE	REVISIONS	DATE
5-8	R.H.	3-30-00	D.H.L.	6-18-05

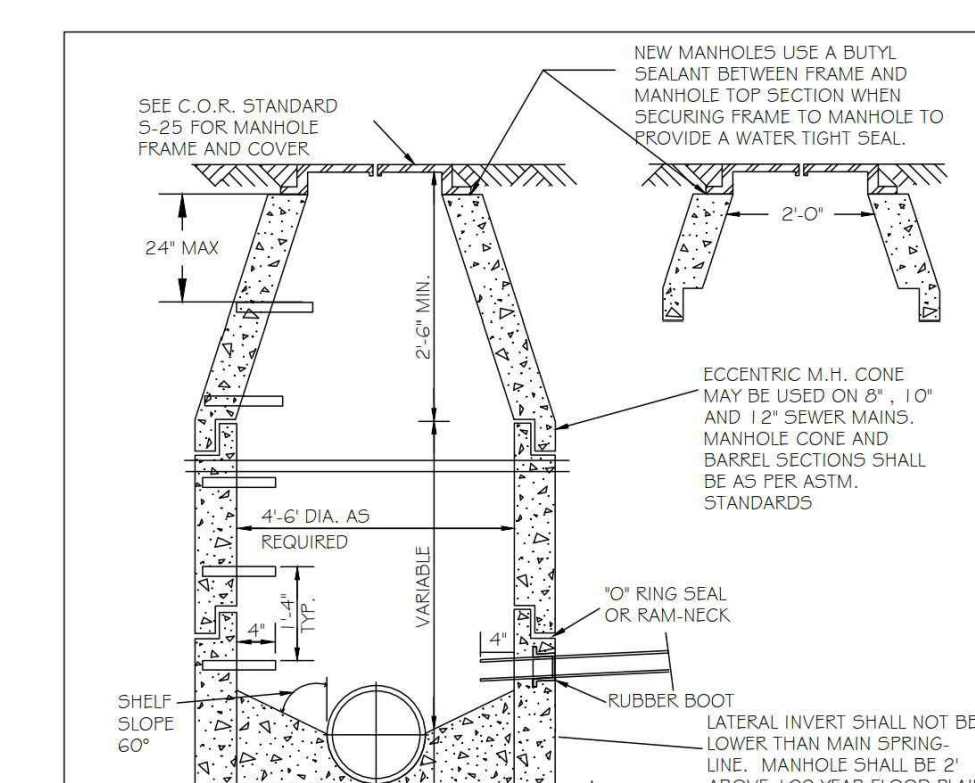

NOTES:  
 1. LATERAL INVERT SHALL NOT BE LOWER THAN MAIN SPRING-LINE. MANHOLE SHALL BE 2' ABOVE 100 YEAR FLOOD PLAIN OR SEALED AND VENT TO BE 2' ABOVE 100 YEAR FLOOD PLAIN, WHEN MANHOLE TOPS ARE IN EXCESS OF 5' ABOVE GRADE. OUTSIDE STEPS MUST BE PROVIDED. SEE STANDARD S-29 FOR STEP DETAIL. IN NON TRAFFIC AREAS, TOP OF FRAME AND COVER SHALL BE INSTALLED A MIN. OF 1' ABOVE FINISHED GROUND SURFACE.  
 2. SEE SEWER DESIGN SECTION.  
 3. MIN. 9" COMPACTED #67 STONE BASE TO BE INSTALLED UNDER NEW MANHOLE.

CITY OF RALEIGH DEPARTMENT OF PUBLIC UTILITIES STANDARD PRECAST SANITARY SEWER MANHOLE				
DWG. NO.	REVISIONS	DATE	REVISIONS	DATE
5-20	T.C.A. R.H.	12-31-92	A.B.B. D.H.L.	3-31-00 6-18-05

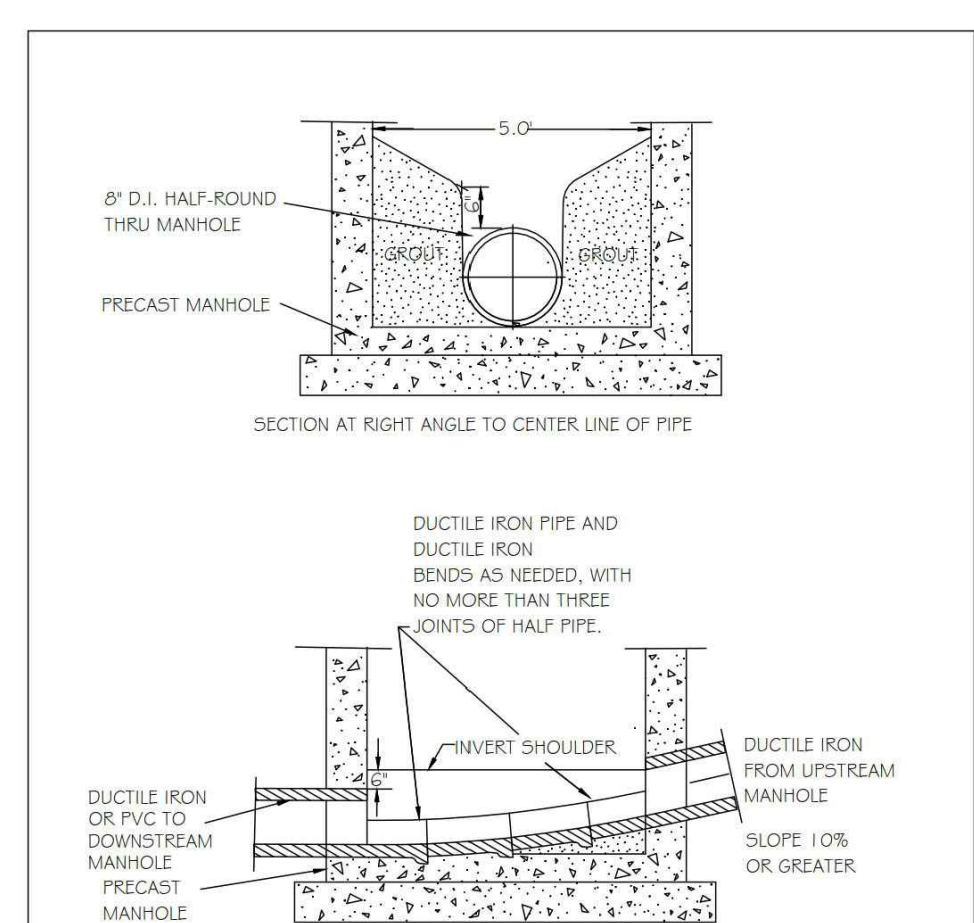

NOTE:  
 NO HORIZONTAL ALIGNMENT CHANGE CAN BE MADE WITH IN THIS MANHOLE TYPE. USE ON GRADES 1.0% OR GREATER.

CITY OF RALEIGH DEPARTMENT OF PUBLIC UTILITIES STANDARD HIGH VELOCITY MANHOLE INVERT				
DWG. NO.	REVISIONS	DATE	REVISIONS	DATE
5-23	T.C.A.	3-1-97	R.H.	3-30-00

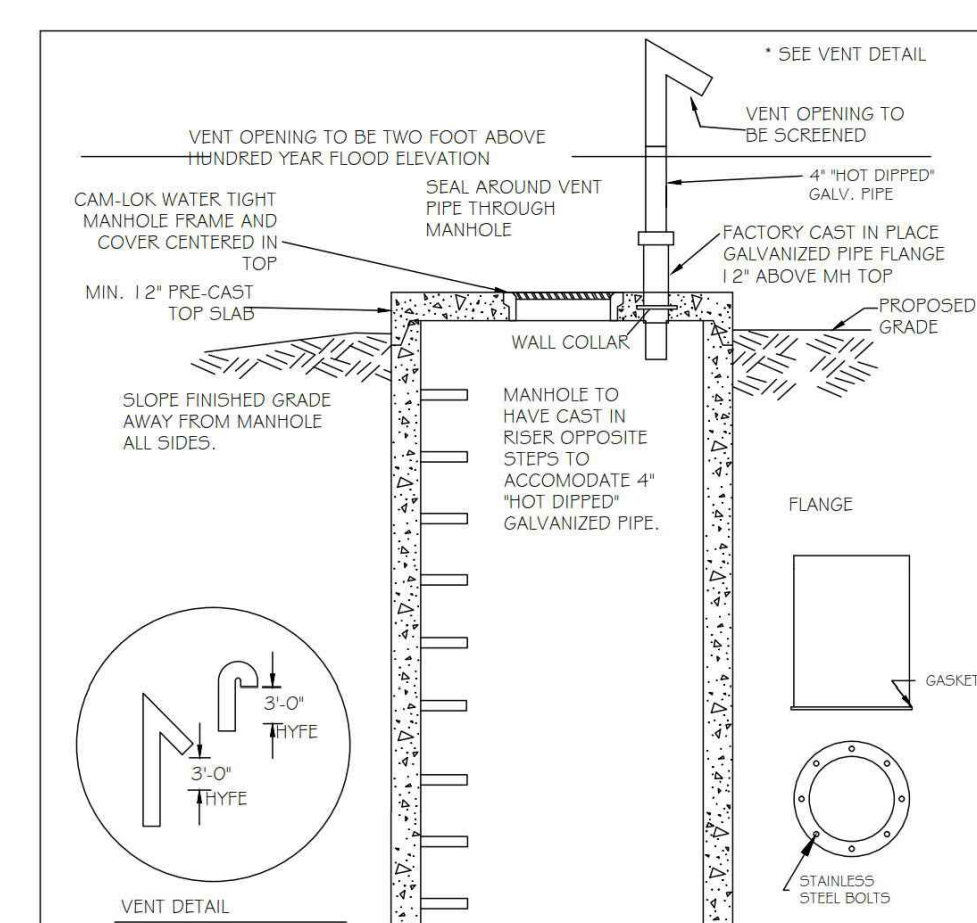

NOTES:  
 1. VENT MUST BE FACTORY WELDED FABRICATED AND "HOT DIPPED" GALVANIZED.  
 2. TYPE - Hundred Year Flood elevation

CITY OF RALEIGH DEPARTMENT OF PUBLIC UTILITIES STANDARD SEAL TIGHT MANHOLE WITH VENTED STACK				
DWG. NO.	REVISIONS	DATE	REVISIONS	DATE
5-24	R.H.	6-7-99	A.B.B. D.H.L.	4-15-04 6-18-05

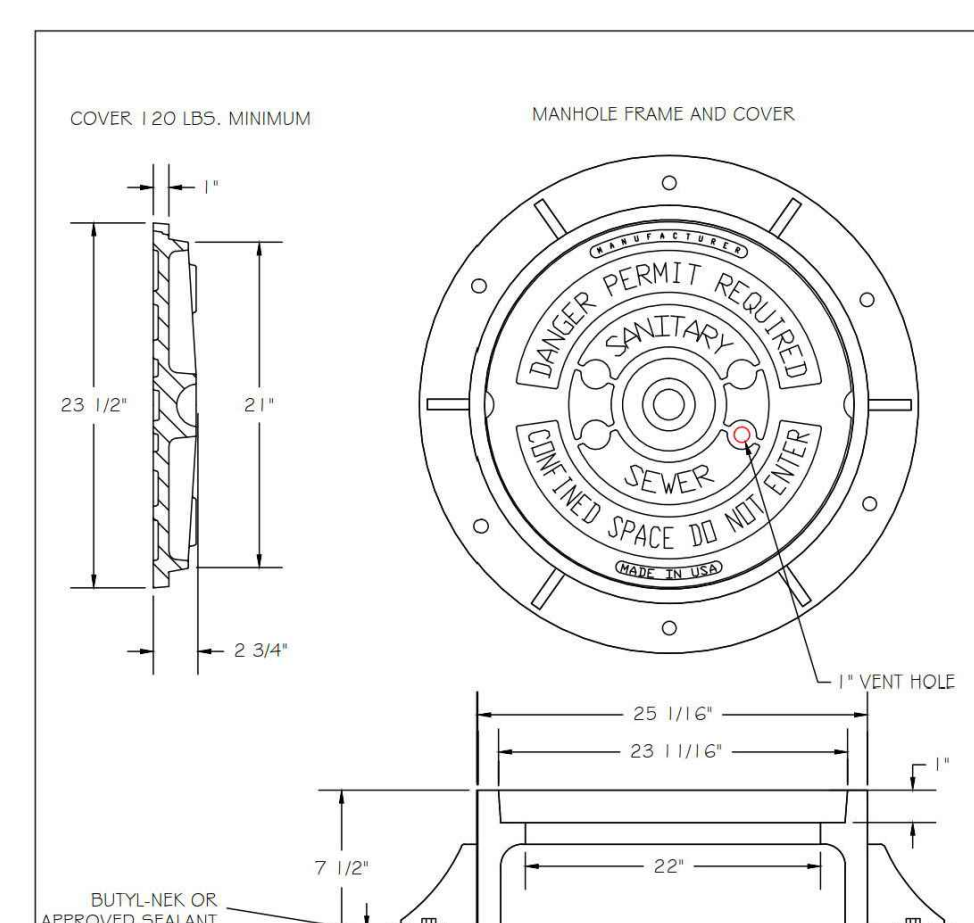

NOTES:  
 1) ALL MANHOLE FRAMES SHALL BE DOMESTICALLY CAST.  
 2) FRAME SHALL BE A MINIMUM WEIGHT OF 162 LBS. WITHIN PUBLIC ROW AND 160 LBS. WITHIN EASEMENTS.  
 3) COVER SHALL WEIGH A MIN. OF 120 LBS.  
 4) ALL MANHOLE FRAMES OUTSIDE OF PAVED SURFACES SHALL BE BOLTED TO THE CONE SECTION OR RING WITH A MINIMUM OF 4 BOLTS PER FRAME.

CITY OF RALEIGH DEPARTMENT OF PUBLIC UTILITIES STANDARD MANHOLE COVER				
DWG. NO.	REVISIONS	DATE	REVISIONS	DATE
5-25	R.H.	3-1-97	A.B.B. D.H.L.	2-9-05 6-18-05

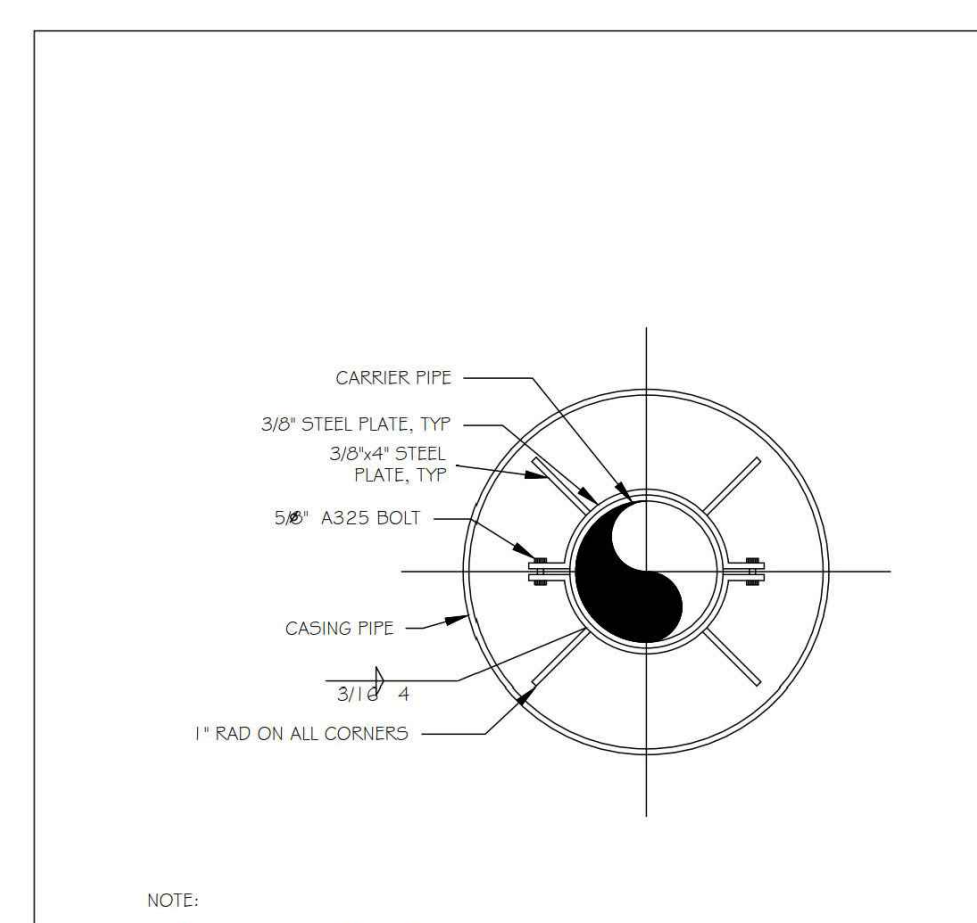

NOTE:  
 1) USE A MINIMUM OF TWO SPIDERS PER PIPE JOINT ONE FOURTH OF THE PIPE JOINT LENGTH IN FROM BOTH THE BELL AND SPIGOT ENDS.

CITY OF RALEIGH DEPARTMENT OF PUBLIC UTILITIES PIPE ALIGNMENT GUIDE				
DWG. NO.	REVISIONS	DATE	REVISIONS	DATE
5-39	R.H. A.B.B.	3-31-00		4-1-04

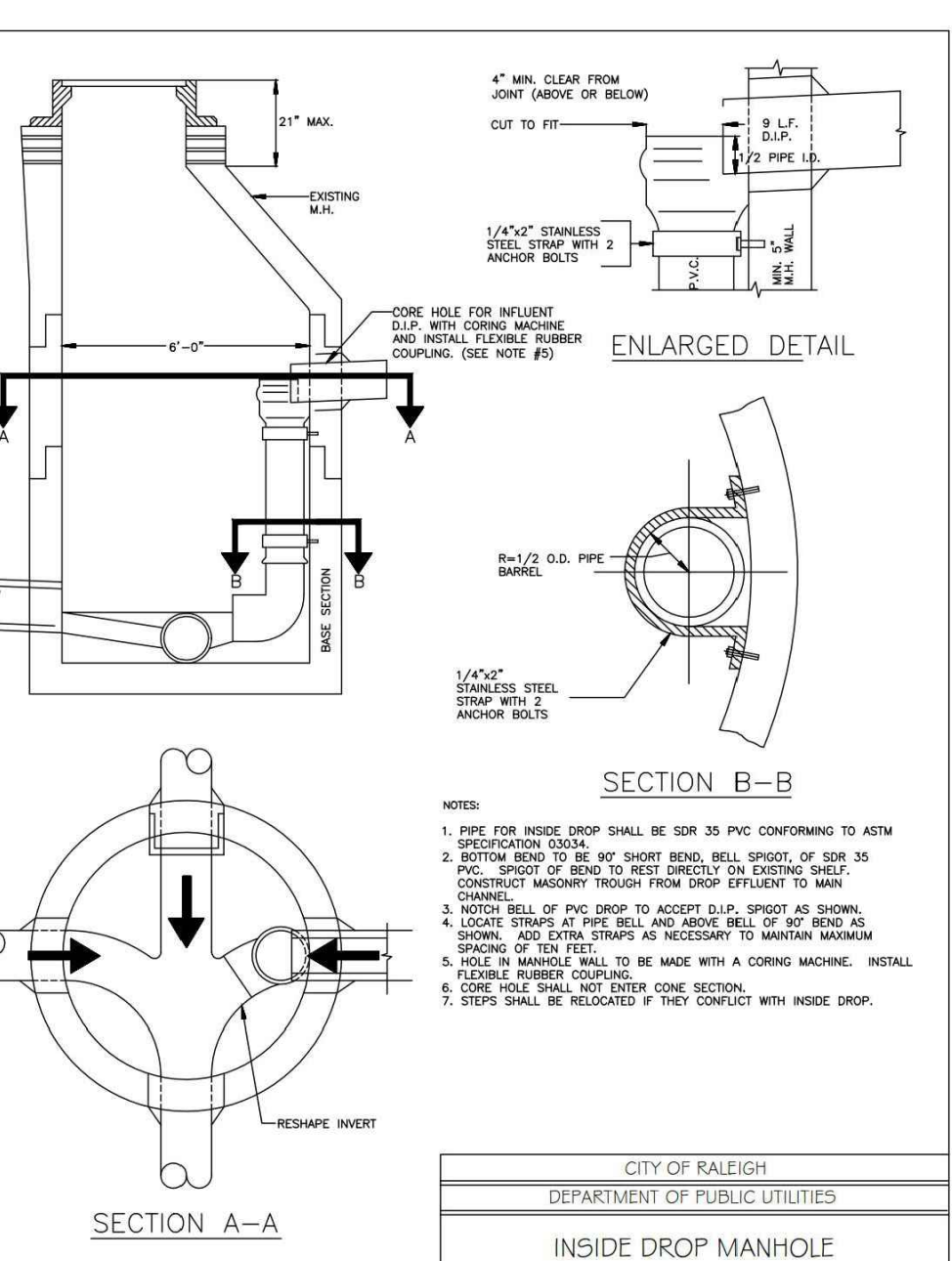

NOTES:  
 1. PIPE FOR INSIDE DROP SHALL BE SDR 35 PVC CONFORMING TO ASTM SPECIFICATION D-3052.  
 2. INSIDE DROP SHALL BE 2' BELOW GRADE.  
 3. WHEN SEWER CLEAN OUT IS IN PAVEMENT OR IMPERVIOUS SURFACE IT MUST BE INSTALLED INSIDE A VALVE BOX (OR MINI-MANHOLE) WITH COVER LABELED "SEWER".  
 4. FINISHED GRADE.  
 5. CAST IRON OR BRONZE CLEAN OUT PLUG.  
 6. INSTALLATIONS BY UTILITY CONTRACTORS BEYOND THE PROPERTY OR EASEMENT LINE REQUIRE A PLUMBING UTILITY PERMIT AND ARE INSPECTED BY THE PLUMBING INSPECTOR. DO NOT BACKFILL PRIOR TO INSPECTION.  
 7. SIZE OF BLOCKING WILL VARY WITH PIPE SIZE.  
 8. 5' MIN.  
 9. 3/4" THREADED STEEL RODS.  
 10. 5' MIN.

CITY OF RALEIGH DEPARTMENT OF PUBLIC UTILITIES INSIDE DROP MANHOLE				
DWG. NO.	REVISIONS	DATE	REVISIONS	DATE
5-53	M.A.B.	11-6-13		

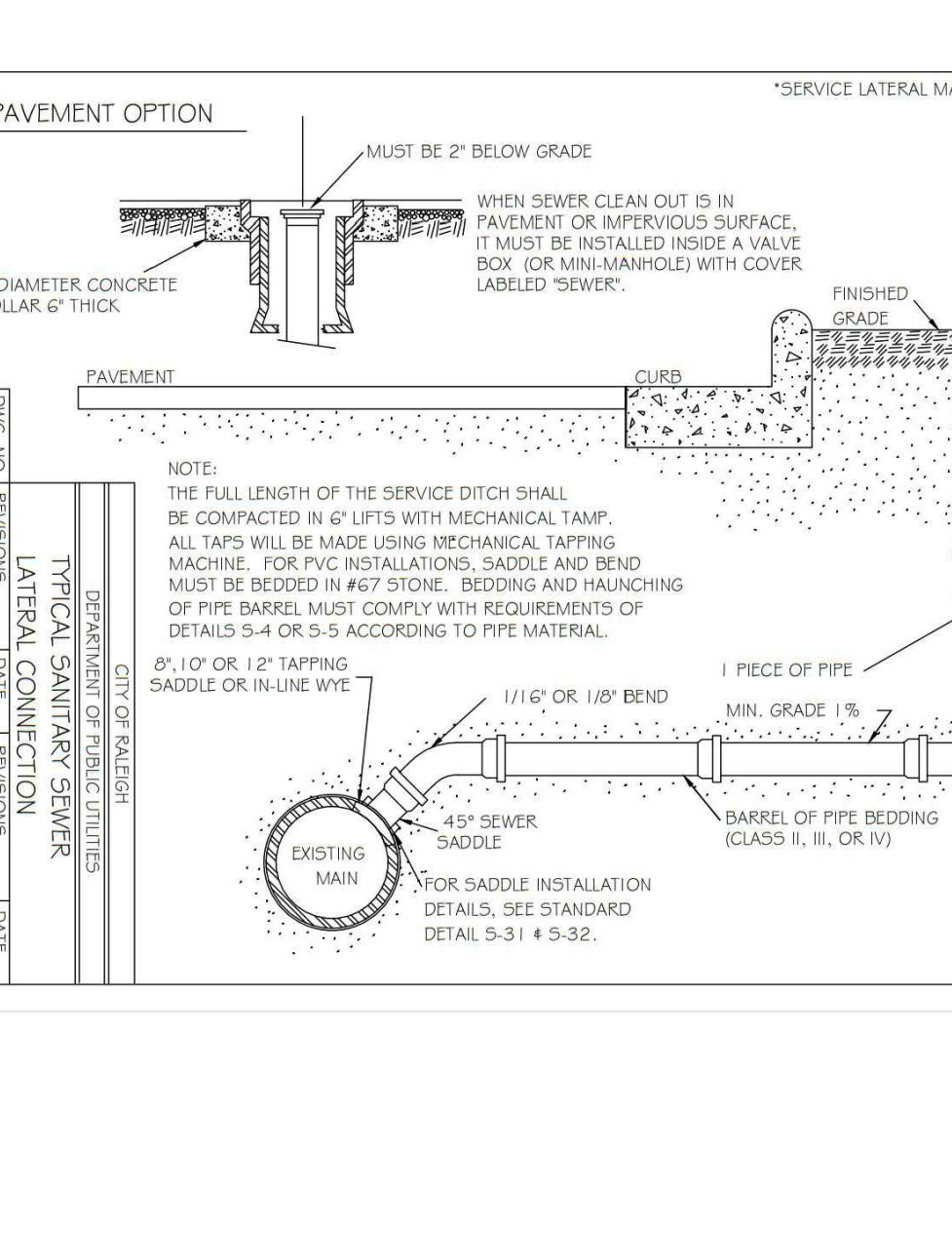

NOTE:  
 THE FULL LENGTH OF THE SERVICE DITCH SHALL BE COMPACTED IN 6" LIFTS WITH MECHANICAL TAMP. ALL TAPS WILL BE MADE USING MECHANICAL TAPPING MACHINE. FOR PVC INSTALLATIONS, SADDLE AND BEND MUST BE BEDDED IN #67 STONE. BEDDING AND HAUNCHING OF PIPE BARREL MUST COMPLY WITH REQUIREMENTS OF DETAILS S-4 OR S-5 ACCORDING TO PIPE MATERIAL.  
 1. 1/16" OR 1/8" TAPPING SADDLE OR IN-LINE WYE.  
 2. 1/16" OR 1/8" BEND.  
 3. 1 PIECE OF PIPE.  
 4. MIN. GRADE 1%.  
 5. 4" O.D. OR PVC PIPE.  
 6. 1/2" EXTENSION WITH PERMANENT PLUG CAP.  
 7. COMBINATION WYE AND 1/2" BEND (ONE PIECE).

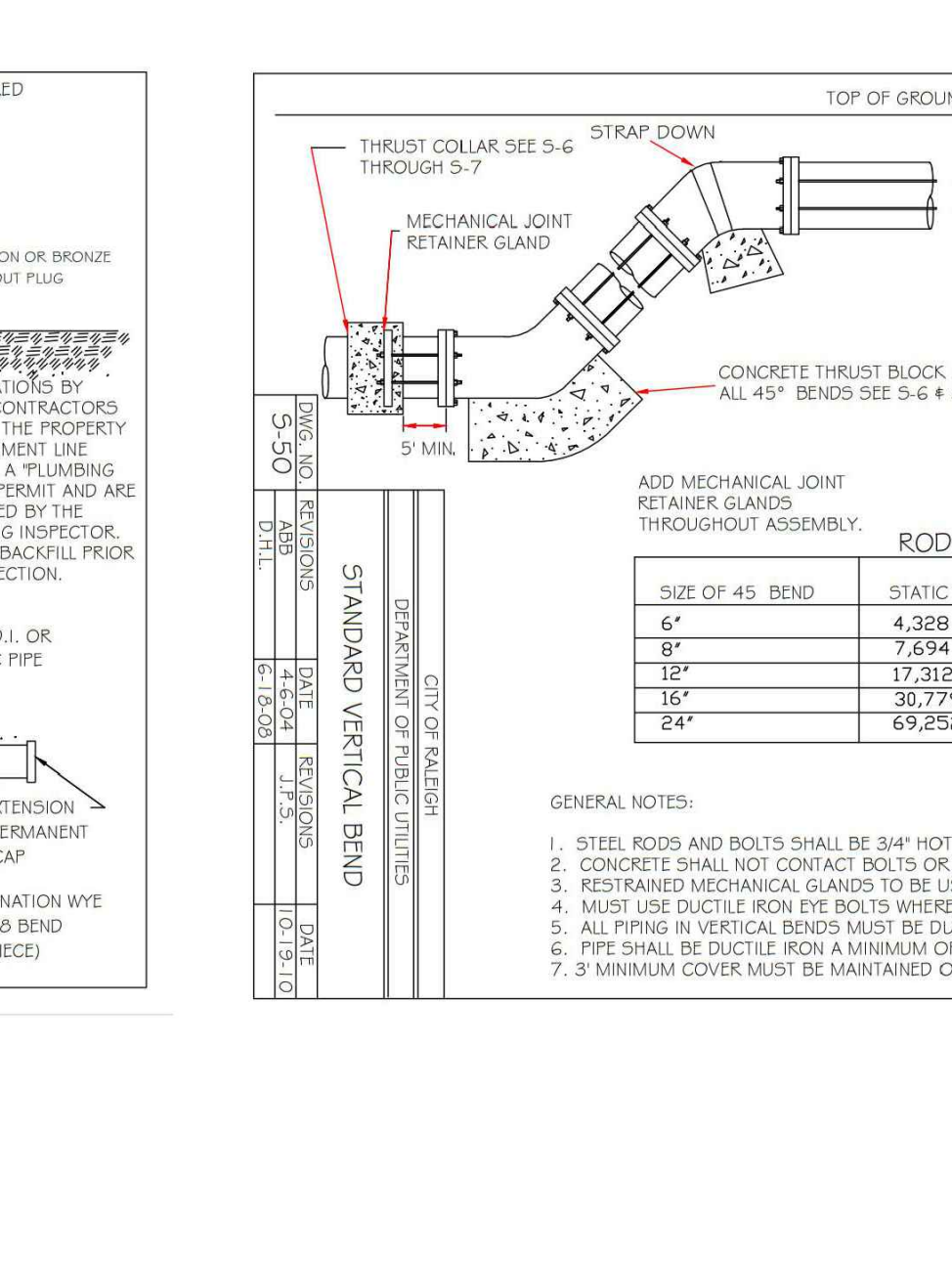

GENERAL NOTES:  
 1. STEEL RODS AND BOLTS SHALL BE 3/4" HOT DIPPED GALVANIZED.  
 2. CONCRETE SHALL NOT CONTACT BOLTS OR ENDS OF MECHANICAL JOINT BENDS.  
 3. RESTRAINED MECHANICAL GLANDS TO BE USED AT ALL FITTINGS.  
 4. MUST USE DUCTILE IRON EYE BOLTS WHERE NECESSARY.  
 5. ALL FITTING IN MECHANICAL BENDS MUST BE DUCTILE IRON.  
 6. PIPE SHALL BE DUCTILE IRON A MINIMUM OF ONE JOINT IN EACH DIRECTION.  
 7. 3" MINIMUM COVER MUST BE MAINTAINED ON ALL FORCE MAINS.

SIZE OF 45° BEND	STATIC THRUST IN POUNDS	NO. OF RODS REQUIRED
6"	4,328	2
8"	7,294	4
12"	17,312	4
15"	30,779	8
24"	69,252	8

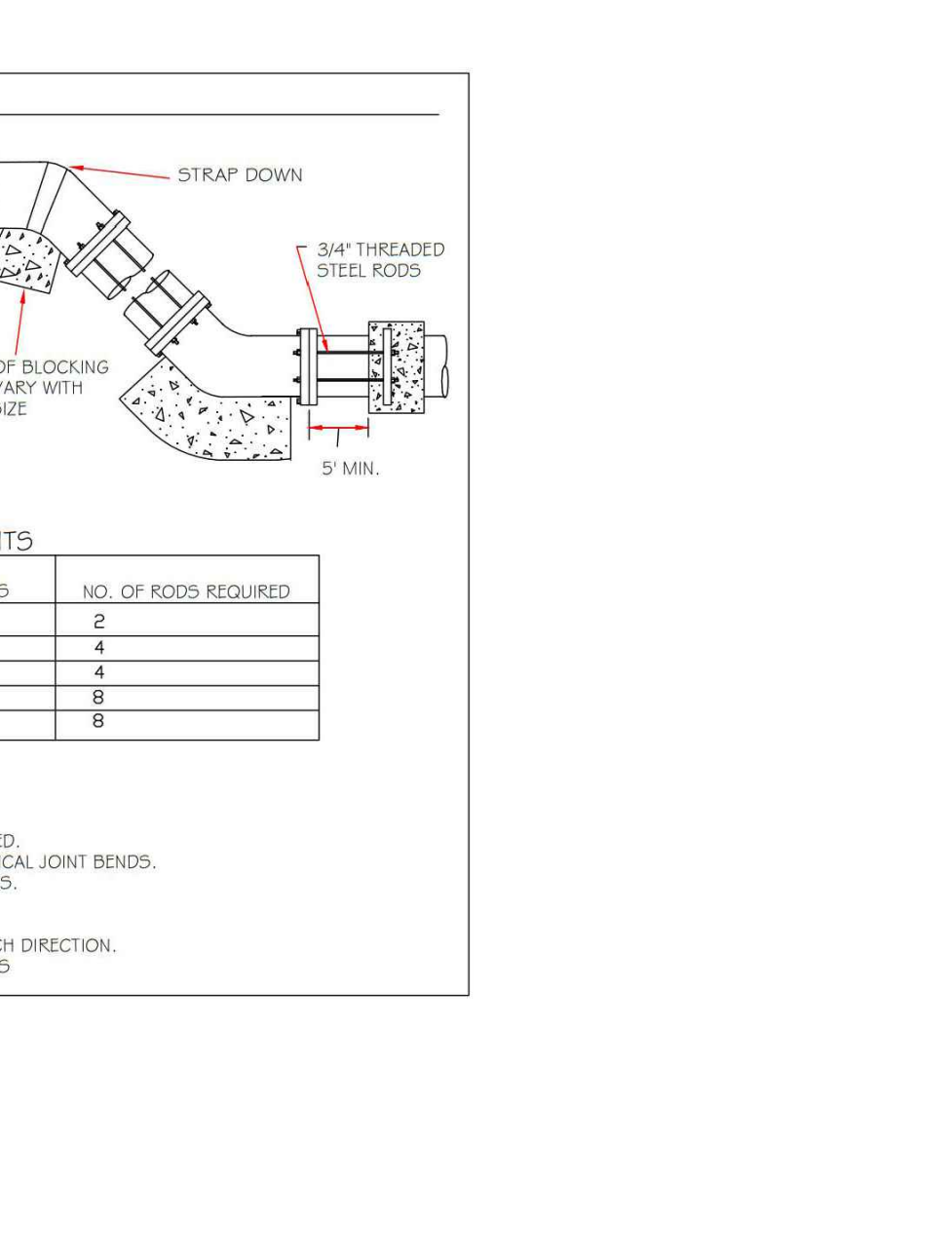

NOTE:  
 1. STEEL RODS AND BOLTS SHALL BE 3/4" HOT DIPPED GALVANIZED.  
 2. CONCRETE SHALL NOT CONTACT BOLTS OR ENDS OF MECHANICAL JOINT BENDS.  
 3. RESTRAINED MECHANICAL GLANDS TO BE USED AT ALL FITTINGS.  
 4. MUST USE DUCTILE IRON EYE BOLTS WHERE NECESSARY.  
 5. ALL FITTING IN MECHANICAL BENDS MUST BE DUCTILE IRON.  
 6. PIPE SHALL BE DUCTILE IRON A MINIMUM OF ONE JOINT IN EACH DIRECTION.  
 7. 3" MINIMUM COVER MUST BE MAINTAINED ON ALL FORCE MAINS.

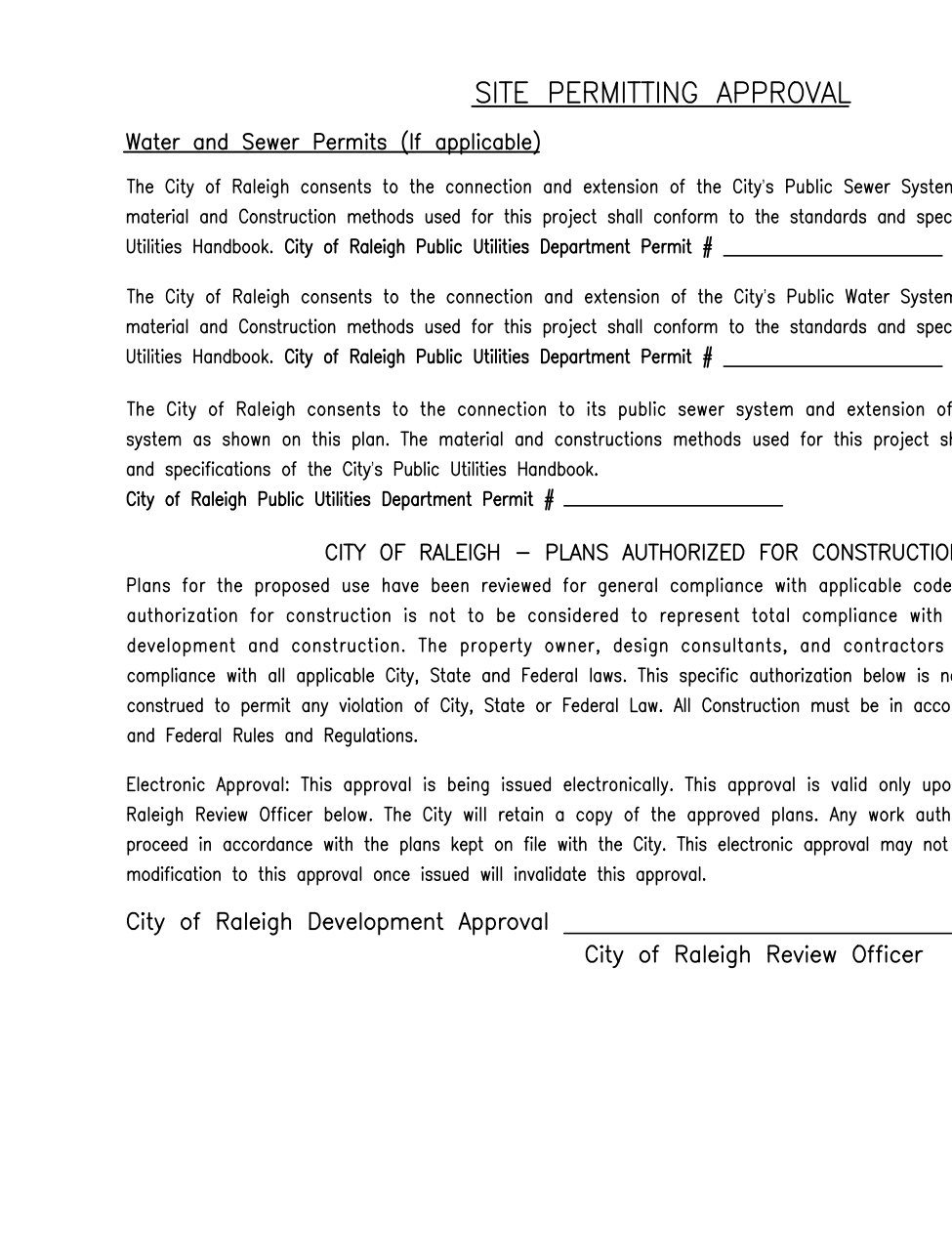

NOTE:  
 1. STEEL RODS AND BOLTS SHALL BE 3/4" HOT DIPPED GALVANIZED.  
 2. CONCRETE SHALL NOT CONTACT BOLTS OR ENDS OF MECHANICAL JOINT BENDS.  
 3. RESTRAINED MECHANICAL GLANDS TO BE USED AT ALL FITTINGS.  
 4. MUST USE DUCTILE IRON EYE BOLTS WHERE NECESSARY.  
 5. ALL FITTING IN MECHANICAL BENDS MUST BE DUCTILE IRON.  
 6. PIPE SHALL BE DUCTILE IRON A MINIMUM OF ONE JOINT IN EACH DIRECTION.  
 7. 3" MINIMUM COVER MUST BE MAINTAINED ON ALL FORCE MAINS.



**McADAMS**  
 The John R. McAdams Company, Inc.  
 2905 Meridian Parkway  
 Durham, NC 27713  
 phone 919. 361. 5000  
 fax 919. 361. 2269  
 license number: C-0293, C-187  
 www.mcadamsco.com

**CLIENT**  
 ASHTON RALEIGH RESIDENTIAL, LLC.  
 5711 SIX FORKS ROAD, SUITE 300  
 RALEIGH, NORTH CAROLINA 27609  
 PHONE: 919. 232. 3695  
 CONTACT: BOB MISHLER



**HARRIS CREEK INTERCEPTOR  
 IMPROVEMENTS**  
 TOWN OF ROLESVILLE, WAKE FOREST TOWNSHIP,  
 WAKE COUNTY, NORTH CAROLINA

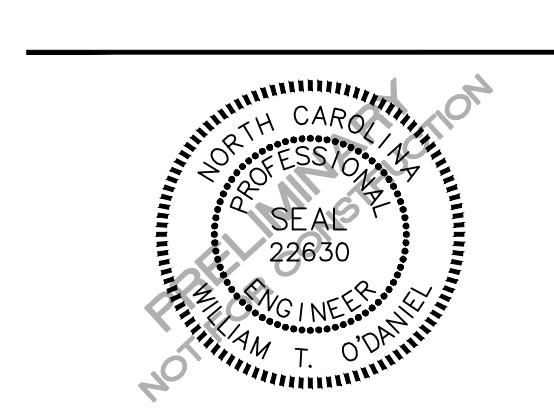

**SITE PERMITTING APPROVAL**

**Water and Sewer Permits (if applicable)**  
 The City of Raleigh consents to the connection and extension of the City's Public Sewer System as shown on this plan. The material and Construction methods used for this project shall conform to the standards and specifications of the City's Public Utilities Handbook, City of Raleigh Public Utilities Department Permit # \_\_\_\_\_

The City of Raleigh consents to the connection and extension of the City's Public Water System as shown on this plan. The material and Construction methods used for this project shall conform to the standards and specifications of the City's Public Utilities Handbook, City of Raleigh Public Utilities Department Permit # \_\_\_\_\_

The City of Raleigh consents to the connection to its public sewer system and extension of the private sewer collection system as shown on this plan. The material and construction methods used for this project shall conform to the standards and specifications of the City's Public Utilities Handbook, City of Raleigh Public Utilities Department Permit # \_\_\_\_\_

**CITY OF RALEIGH - PLANS AUTHORIZED FOR CONSTRUCTION**  
 Plans for the proposed use have been reviewed for general compliance with applicable codes. This limited review, and authorization for construction is not to be considered to represent total compliance with all legal requirements for development and construction. The property owner, design consultants, and contractors are each responsible for compliance with all applicable City, State and Federal laws. This specific authorization below is not a permit, nor shall it be construed to permit any violation of City, State or Federal Law. All Construction must be in accordance with all Local, State, and Federal Rules and Regulations.

Electronic Approval: This approval is being issued electronically. This approval is valid only upon the signature of a City of Raleigh Review Officer below. The City will retain a copy of the approved plans. Any work authorized by this approval must proceed in accordance with the plans kept on file with the City. This electronic approval may not be relied upon issued. Any modification to this approval once issued will invalidate this approval.

City of Raleigh Development Approval \_\_\_\_\_  
 City of Raleigh Review Officer \_\_\_\_\_

**REVISIONS**

NO.	DATE

**PLAN INFORMATION**

PROJECT NO. AWH-20000  
 FILENAME AWH20000-D1  
 CHECKED BY .  
 DRAWN BY .  
 SCALE N.T.S.  
 DATE 10. 12. 2021

**SHEET**

**SANITARY SEWER  
 DETAILS  
 C8.01**

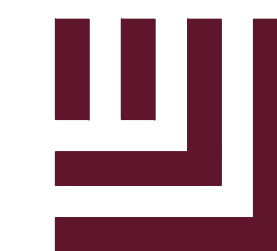

**McADAMS**

The John R. McAdams Company, Inc.  
2905 Meridian Parkway  
Durham, NC 27713

phone 919. 361. 5000  
fax 919. 361. 2269  
license number: C-0293, C-187

www.mcadamsco.com

**CLIENT**

ASHTON RALEIGH RESIDENTIAL, LLC.  
5711 SIX FORKS ROAD, SUITE 300  
RALEIGH, NORTH CAROLINA 27609  
PHONE: 919. 232. 3695  
CONTACT: BOB MISHLER

\\images\Ashton Woods logo.jpg

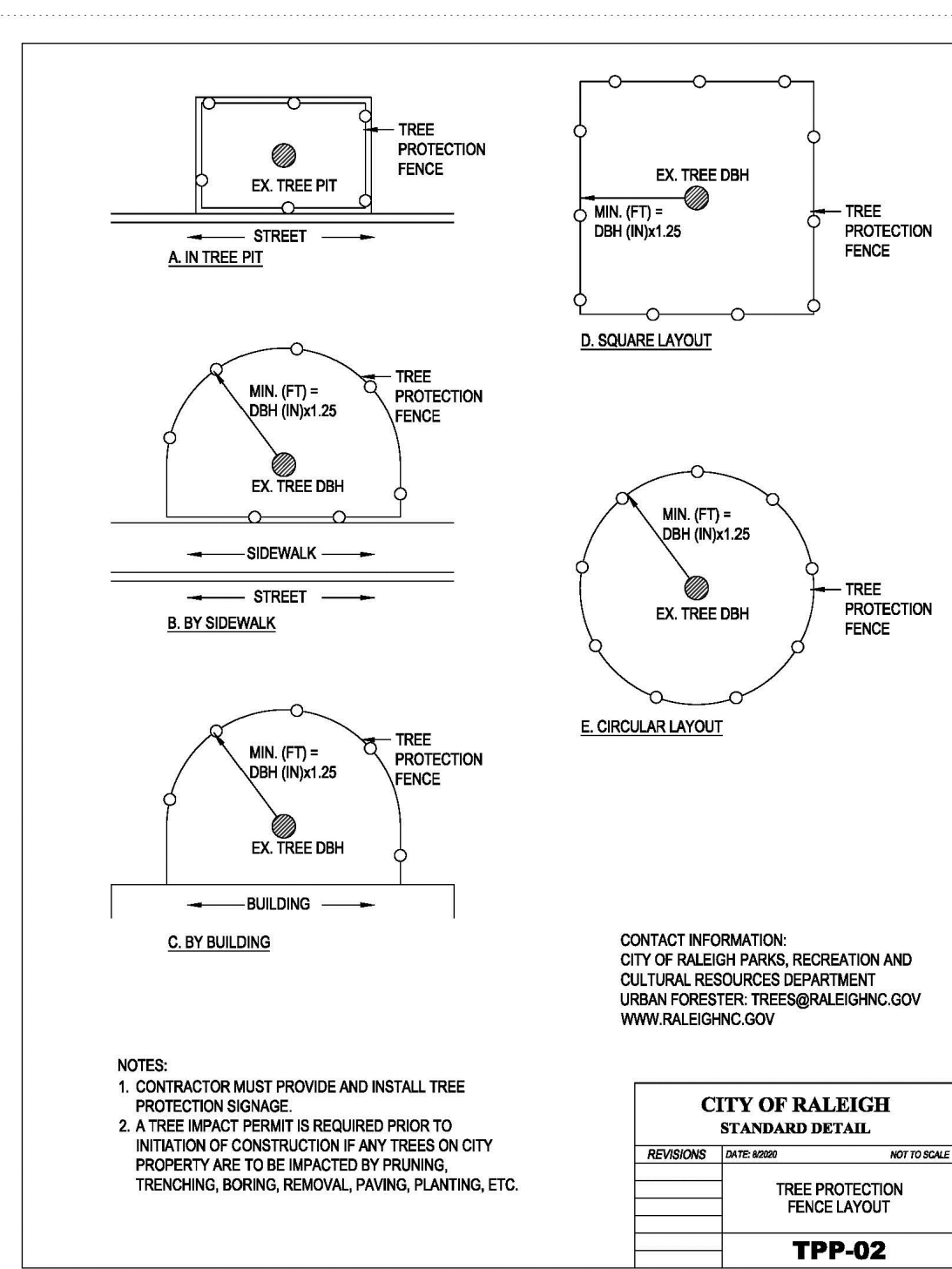
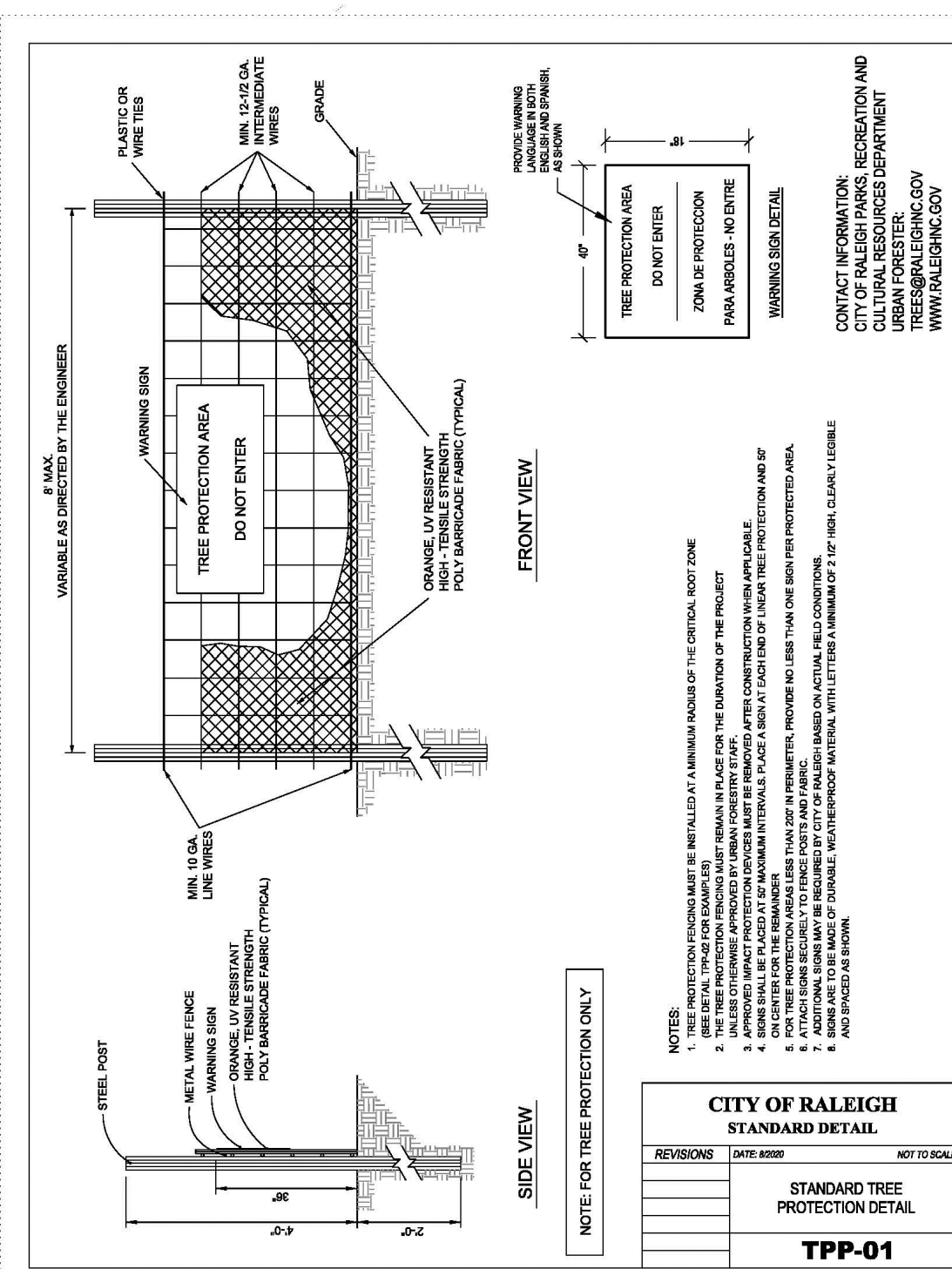
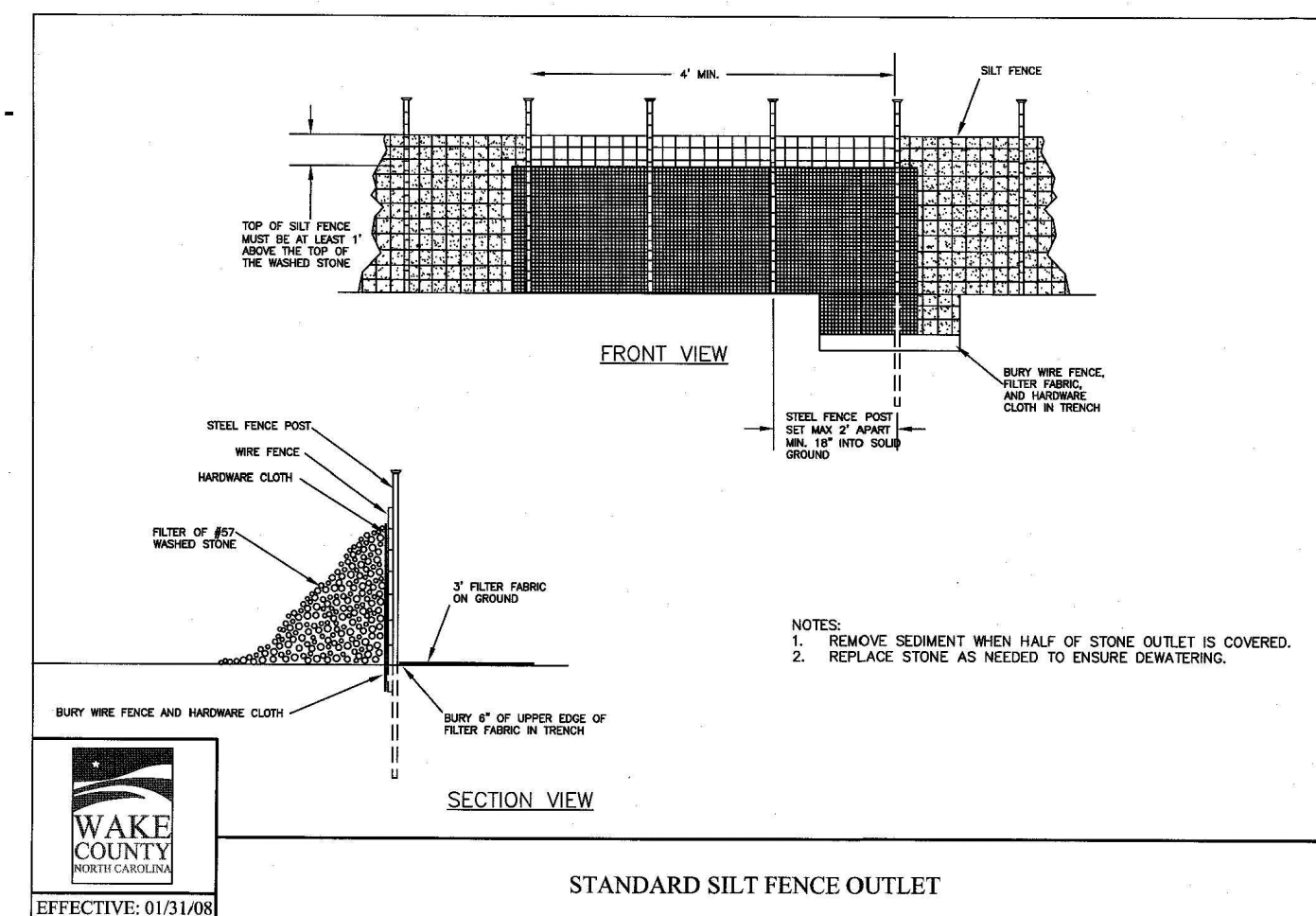
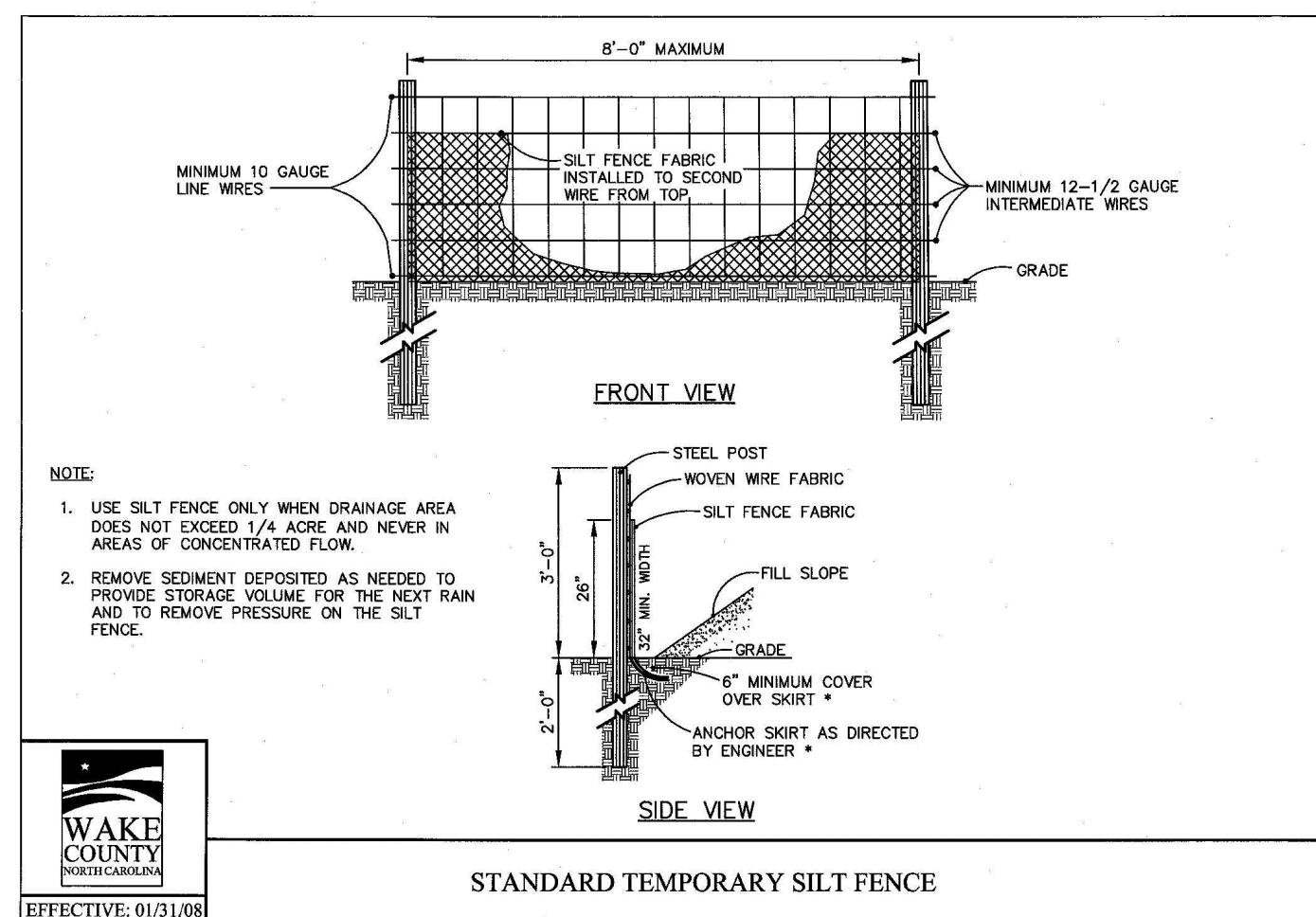

**HARRIS CREEK INTERCEPTOR IMPROVEMENTS**  
TOWN OF ROLESVILLE, WAKE FOREST TOWNSHIP,  
WAKE COUNTY, NORTH CAROLINA

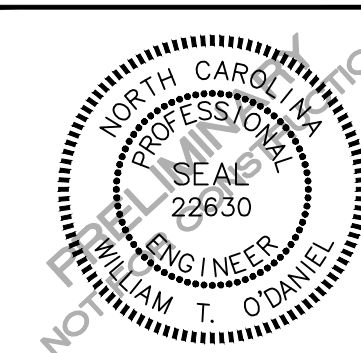

**SITE PERMITTING APPROVAL**

**Water and Sewer Permits (if applicable)**

The City of Raleigh consents to the connection and extension of the City's Public Sewer System as shown on this plan. The material and Construction methods used for this project shall conform to the standards and specifications of the City's Public Utilities Handbook, City of Raleigh Public Utilities Department Permit # \_\_\_\_\_

The City of Raleigh consents to the connection and extension of the City's Public Water System as shown on this plan. The material and Construction methods used for this project shall conform to the standards and specifications of the City's Public Utilities Handbook, City of Raleigh Public Utilities Department Permit # \_\_\_\_\_

The City of Raleigh consents to the connection to its public sewer system and extension of the private sewer collection system as shown on this plan. The material and constructions methods used for this project shall conform to the standards and specifications of the City's Public Utilities Handbook, City of Raleigh Public Utilities Department Permit # \_\_\_\_\_

**CITY OF RALEIGH - PLANS AUTHORIZED FOR CONSTRUCTION**

Plans for the proposed use have been reviewed for general compliance with applicable codes. This limited review, and authorization for construction is not to be considered to represent total compliance with all legal requirements for development and construction. The property owner, design consultants, and contractors are each responsible for compliance with all applicable City, State and Federal laws. This specific authorization below is not a permit, nor shall it be construed to permit any violation of City, State or Federal Law. All Construction must be in accordance with all Local, State, and Federal Rules and Regulations.

Electronic Approval: This approval is being issued electronically. This approval is valid only upon the signature of a City of Raleigh Review Officer below. The City will retain a copy of the approved plans. Any work authorized by this approval must proceed in accordance with the plans kept on file with the City. This electronic approval may not be edited once issued. Any modification to this approval once issued will invalidate this approval.

City of Raleigh Development Approval \_\_\_\_\_  
City of Raleigh Review Officer

**REVISIONS**

NO.	DATE

**PLAN INFORMATION**

PROJECT NO.	AWH-20000
FILENAME	AWH20000-D1
CHECKED BY	.
DRAWN BY	.
SCALE	N.T.S.
DATE	10.12.2021

**SHEET**

**EROSION CONTROL DETAILS**

**C8.02**