

WALLBROOK OFFSITE UTILITY IMPROVEMENTS

ROLESVILLE, NC

WALLBROOK LANDCO

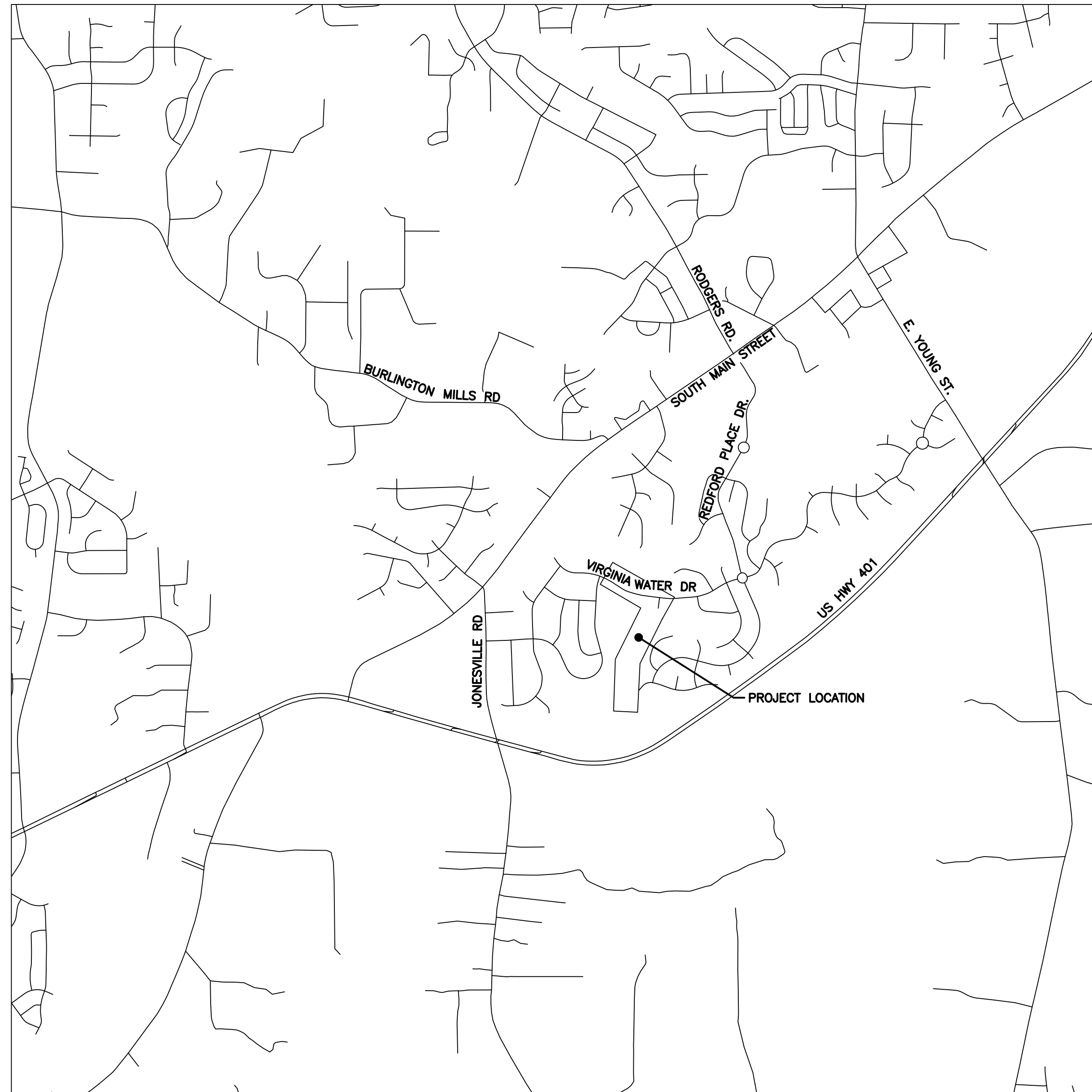

APPROXIMATE SITE ADDRESS: 250 VIRGINIA WATER DR, ROLESVILLE, NC 27571



- Traffic Control and Pedestrian Plan (TCPED) Notes:**
- Prior to any work that impacts the right-of-way, closing or detouring of any street, lane, or sidewalk, the contractor must apply for a permit with Right-of-Way Services. Please direct any questions to rightofwayservices@raleighnc.gov.
 - The City of Raleigh requires an approved Right-of-Way Permit for work on any public street or sidewalk and NCDOT road within Raleigh's Jurisdiction.
 - A permit request with a TCPED Plan shall be submitted to Right-of-Way Services through the City of Raleigh Permit and Development Portal.
 - Prior to the start of work, the Client shall schedule a Pre-Construction meeting with the Engineering Inspections Coordinator to review the specific components of the approved plan, and ensure all permits are issued.
 - All TCPED Plans shall comply with all Local, State, and Federal requirements and standards, including but not limited to:
 - Manual on Uniform Traffic Control (MUTCD);
 - Public Rights-of-Way Accessibility Guidelines (PROWAG);
 - American Disability Act (ADA) requirements;
 - Raleigh Street Design Manual (RSDM).
 - All public sidewalks must be accessible to pedestrians who are visually impaired and/or people with mobility concerns. Existing and alternative pedestrian routes during construction shall be required to be compliant with the Public Rights of Way Accessibility Guidelines (PROWAG), the ADA Standards for Accessible Design and the Manual on Uniform Traffic Control Devices (MUTCD).
 - All permits must be available and visible on site during the operation.

ATTENTION CONTRACTORS

The **Construction Contractor** responsible for the extension of water, sewer, and/or reuse, as approved in these plans, is responsible for **contacting the Public Works Department at (919) 996-2409**, and the **Public Utilities Department at (919)-857-4540** at least **twenty four hours** prior to beginning any of their construction.

Failure to notify both **City Departments** in advance of beginning construction, will result in the issuance of **monetary fines**, and require reinstallation of any water or sewer facilities not inspected as a result of this notification failure.

Failure to call for **Inspection, Install a Downstream Plug**, have **Permitted Plans on the Jobsite**, or any other **Violation of City of Raleigh Standards** will result in a **Fine and Possible Exclusion** from future work in the **City of Raleigh**.

SITE PERMITTING APPROVAL

Water and Sewer Permits (If applicable)

The City of Raleigh consents to the connection and extension of the City's **Public Sewer System** as shown on this plan. The material and Construction methods used for this project shall conform to the standards and specifications of the City's Public Utilities Handbook.
City of Raleigh Public Utilities Department Permit # S-5180

The City of Raleigh consents to the connection and extension of the City's **Public Water System** as shown on this plan. The material and Construction methods used for this project shall conform to the standards and specifications of the City's Public Utilities Handbook.
City of Raleigh Public Utilities Department Permit # N/A

The City of Raleigh consents to the connection and extension of its public sewer system and extension of the private sewer collection system as shown on this plan. The material and Construction methods used for this project shall conform to the standards and specifications of the City's Public Utilities Handbook.
City of Raleigh Public Utilities Department Permit # N/A

SCHEDULE OF DRAWINGS

SHEET	TITLE
COVER	VICINITY MAP AND SCHEDULE OF DRAWINGS
C-0.0	GENERAL NOTES
C-0.1	LEGEND, ABBREVIATIONS AND SHEET LAYOUT
C-0.2	TECHNICAL SPECIFICATIONS
C-1.0	VIRGINIA WATER DRIVE STA 10+00 TO STA 19+00
C-1.1	SOUTH OF TRILICK CT STA 22+50 TO 31+00
C-1.2	SOUTH OF TRILICK CT STA 31+00 TO 40+50
ED-1.0	EROSION CONTROL DETAILS
ED-2.0	EROSION CONTROL DETAILS
ED-3.0	EROSION CONTROL DETAILS
SD-1.0	STANDARD DETAILS
SD-2.0	STANDARD DETAILS
TD-1.0	TRAFFIC CONTROL DETAILS
TD-2.0	TRAFFIC CONTROL DETAILS

PUBLIC IMPROVEMENT QUANTITIES	
PHASE NUMBER	0
NUMBER OF LOTS	0
LOT NUMBER(S) BY PHASE	0
NUMBER OF UNITS	0
LIVABLE BUILDINGS	0
OPEN SPACE	0
NUMBER OF OPEN SPACE LOTS	0
PUBLIC WATER (LF)	0
PUBLIC SEWER (LF)	1,823 LF
PUBLIC STREET (LF)-FULL	0
PUBLIC STREET (LF)-PARTIAL	0
PUBLIC SIDEWALK (LF)	0
WATER SERVICE STUBS	0
SEWER SERVICE STUBS	0

EROSION AND SEDIMENT CONTROL

APPROVED PLAN

DATE _____

PERMIT NO. S-SEC-094784-2022

Wake County Environmental Services
 Sedimentation & Erosion Control
 919-856-7400

ENVIRONMENTAL CONSULTANT SIGNATURE _____

CITY OF RALEIGH - PLANS AUTHORIZED FOR CONSTRUCTION

Plans for the proposed use have been reviewed for general compliance with applicable codes. This limited review, and authorization for construction is not to be considered to represent total compliance with all legal requirements for development and construction. The property owner, design consultants, and contractors are each responsible for compliance with all applicable City, State and Federal laws. This specific authorization below is not a permit, nor shall it be construed to permit any violation of City, State or Federal Law. All construction must be in accordance with all Local, State, and Federal Rules and Regulations.

Electronic Approval: This approval is being issued electronically. This approval is valid only upon the signature of a City of Raleigh Review Officer below. The City will retain a copy of the approved plans. Any work authorized by this approval must proceed in accordance with the plans kept on file with the City. This electronic approval may not be edited once issued. Any modification to this approval once issued will invalidate this approval.

City of Raleigh Development Approval _____
 City of Raleigh Review Officer

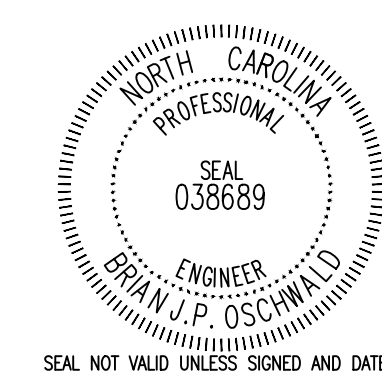

HIGHFILL
 INFRASTRUCTURE
 ENGINEERING, P.C.

2703 Jones Franklin Rd., Suite 201
 Cary, North Carolina 27518
 Tel 919-481-4342
 Fax 919-882-9762
 www.hiepc.com
 Firm License No. C-2586

Engineering is our profession. Service is our passion.

HIGHFILL PROJECT NO. CSE2201
 TOWN OF ROLESVILLE PROJECT NO. CD 22-06
 WALLBROOK LANDCO
 FEBRUARY 2023

**PRELIMINARY DESIGN NOT
 RELEASED FOR CONSTRUCTION**

WALLBROOK OFFSITE UTILITY IMPROVEMENTS (HIGHFILL PROJ. NO. CSE2201)

GENERAL NOTES:

- 1. EXISTING SURVEY DATA PROVIDED BY CAWTHORNE, MOSS & PANCIERA, PC FOR ENGINEERING PURPOSES ONLY, NOT FOR RECORDATION. ELEVATIONS SHOWN ARE BASED ON NAVD83, HORIZONTAL DATUM IN NAD83.
2. THE DRAWINGS DO NOT SHOW ALL HOMES AND BUSINESSES IN THE PROJECT AREAS OR OTHER EXISTING UTILITIES. THE CONTRACTOR IS ADVISED THAT THE AREAS ARE CONGESTED WITH HOMES, BUSINESSES, AND UTILITIES. THE CONTRACTOR SHALL MAKE NECESSARY SITE INVESTIGATIONS TO DETERMINE ACTUAL UTILITY LOCATIONS, OBSTACLES, HOMES, ETC. PRIOR TO BIDDING.
3. BUILDING LOCATIONS ARE APPROXIMATE AND ARE SHOWN FOR INFORMATIONAL PURPOSES ONLY. NOT ALL BUILDINGS ARE SHOWN.
4. WORK SHALL COMPLY WITH APPLICABLE STATE, FEDERAL, AND LOCAL CODES. NECESSARY LICENSES AND PERMITS SHALL BE OBTAINED BY CONTRACTOR AT ITS EXPENSE, UNLESS PREVIOUSLY OBTAINED BY THE OWNER AND PROVIDED IN THE CONTRACT DOCUMENTS.
5. THE CONTRACTOR SHALL HAVE A COMPLETE SET OF CONTRACT DOCUMENTS AS WELL AS ALL PERMIT APPROVALS AND EASEMENTS ON THE JOB SITE AT ALL TIMES.
6. THE CONTRACTOR SHALL NOTIFY THE ENGINEER IMMEDIATELY SHOULD ANY FIELD CONDITIONS BE ENCOUNTERED THAT VARY FROM THE INFORMATION PROVIDED IN THE CONTRACT DOCUMENTS.
7. DEVIATION FROM THE CONTRACT DOCUMENTS WITHOUT THE PRIOR WRITTEN CONSENT OF THE DEVELOPER, UTILITY OWNER, OR THE ENGINEER MAY BE CAUSE FOR THE WORK TO BE DEEMED UNACCEPTABLE.
8. AT LEAST FIVE BUSINESS DAYS PRIOR TO COMMENCING CONSTRUCTION, CONTRACTOR SHALL NOTIFY DEVELOPER, UTILITY OWNER, TOWN OF ROLESVILLE, ENGINEER AND APPLICABLE REGULATORY AGENCIES THAT THEY ARE PREPARED TO COMMENCE.
9. CONTRACTOR SHALL CALL NC 811 FOR UTILITY LOCATIONS PRIOR TO DIGGING.
10. CONTRACTOR SHALL BE RESPONSIBLE FOR COORDINATING WORK WITH DUKE ENERGY. SUPPORT EXISTING UTILITY POLES AS REQUIRED FOR EXCAVATION AND INSTALLATION OF THE WORK. COSTS OF SUCH WORK SHALL BE PAID BY CONTRACTOR.
11. BURIED TELEPHONE AND CATV CABLES (FIBER OPTICS AND CONVENTIONAL) ARE KNOWN TO VARY DUE TO INSTALLATION TECHNIQUES. CONTRACTOR SHALL COORDINATE WORK WITH CONFLICTING TELEPHONE AND CATV CABLES AS INCLUDED IN THE PROJECT SCHEDULE AND IT IS THE EXPLICIT RESPONSIBILITY OF CONTRACTOR TO ASSURE THAT THE PROJECT SCHEDULE INCLUDES THE NECESSARY COORDINATION.
12. REASONABLE CARE HAS BEEN EXERCISED IN SHOWING THE LOCATION OF EXISTING UTILITIES ON THE PLANS. THE EXACT LOCATION OF ALL EXISTING UTILITIES IS NOT KNOWN IN ALL CASES. THE CONTRACTOR SHALL EXPLORE THE AREA AHEAD OF EXCAVATION OPERATIONS BY OBSERVATION, ELECTRONIC DEVICES, HAND DIGGING, AND BY PERSONAL CONTACT WITH THE UTILITY COMPANIES TO DETERMINE THE ACTUAL LOCATION OF ALL EXISTING UTILITIES IN AN EFFORT TO AVOID INFLECTING DAMAGE TO THOSE UTILITIES. THE CONTRACTOR SHALL BE RESPONSIBLE FOR UTILITY RELOCATION COSTS IF REQUIRED FOR CONTRACTOR'S METHOD OF CONSTRUCTION. THE CONTRACTOR SHALL BE RESPONSIBLE FOR ALL COSTS RESULTING FROM DAMAGE TO THE EXISTING UTILITIES ARISING FROM CONSTRUCTION OF THIS PROJECT. SUCH COSTS INCLUDE LOSS OF UTILITY REVENUES. IF NECESSARY, CONTRACTOR SHALL ARRANGE FOR RELOCATION OR TEMPORARY SUPPORT OF EXISTING UTILITIES SUCH AS POLES, CONDUITS, CABLES, WATER AND SEWER MAINS, ETC.
13. CONTRACTOR SHALL MAKE EVERY EFFORT TO PRESERVE PROPERTY IRONS, MONUMENTS, OTHER PERMANENT POINTS AND LINES OF REFERENCE AND CONSTRUCTION STAKES. PROPERTY IRONS, MONUMENTS, AND OTHER PERMANENT POINTS OF REFERENCE DESTROYED BY THE CONTRACTOR SHALL BE REPLACED BY A PROFESSIONAL LAND SURVEYOR AT THE CONTRACTOR'S EXPENSE.
14. CONTRACTOR IS RESPONSIBLE FOR ALL SURVEY REQUIRED FOR CONSTRUCTION.
15. CONTRACTOR ACTIVITY SHALL BE LIMITED TO STREETS RIGHTS-OF-WAY AND CITY EASEMENTS.
16. CONTRACTOR SHALL CLEAR AND GRUB THE CONSTRUCTION CORRIDOR AND ALL UTILITY EASEMENT ONLY TO THE EXTENT REQUIRED FOR SANITARY SEWER MAIN INSTALLATION. CONTRACTOR SHALL MAKE EVERY EFFORT TO PROTECT TREES THAT WILL NOT BE REMOVED DURING CONSTRUCTION.
17. CONTRACTOR SHALL MAINTAIN ACCESS TO EACH PROPERTY AND BUSINESS AT ALL TIMES.
18. PRIOR TO DISTURBANCE, CONTRACTOR SHALL VIDEOTAPE SEWER ALIGNMENT INCLUDING EACH DRIVEWAY, SIDEWALK, STRUCTURE, ETC., TO BE DISTURBED. EACH SHALL BE RESTORED TO ITS PRECONSTRUCTION CONDITION OR BETTER. VIDEO SHALL BE SUBMITTED TO ENGINEER PRIOR TO WORK.
19. CONTRACTOR SHALL RESTORE/REPLACE ALL DISTURBED SIGNS, MAILBOXES, STORM DRAINS, ETC. TO ORIGINAL CONDITION AND LOCATION AS SOON AS THE CONSTRUCTION PROGRESSES BEYOND THAT LOCATION. IN NO CIRCUMSTANCES SHALL POSTAL SERVICE BE INTERRUPTED TO PROPERTIES ALONG THE CONSTRUCTION CORRIDOR.
20. ALL ROADSIDE DITCHES DISTURBED DURING CONSTRUCTION SHALL BE RESTORED TO PRE-CONSTRUCTION CONDITION OR BETTER AND STABILIZED WITH STRAW AND NET MATTING UNLESS OTHERWISE INDICATED.
21. ALL MATERIAL CLEARED OR DEMOLISHED BY THE CONTRACTOR IN ORDER TO PERFORM THE WORK SHALL BECOME THE PROPERTY OF THE CONTRACTOR AND SHALL BE PROPERLY DISPOSED OF OFF SITE. NO BURNING WILL BE ALLOWED.
22. RELATIONSHIP OF SANITARY SEWER TO EXISTING UTILITIES (15A NCAC 02T .0305)
A) SANITARY SEWER SHALL MAINTAIN MINIMUM VERTICAL SEPARATION OF 24" FROM STORM SEWERS.
B) SANITARY SEWER SHALL MAINTAIN MINIMUM VERTICAL SEPARATION OF 18" FROM WATER MAINS, OR A HORIZONTAL MINIMUM SEPARATION OF 10".
23. AT LOCATIONS WHERE SANITARY SEWER MUST BE INSTALLED WITH LESS THAN 24" SEPARATION FROM STORM DRAINS DUE TO SURROUNDING CONDITIONS, THE TRENCH SHALL BE BACKFILLED WITH CLASS M (FLOWABLE FILL) CONCRETE UP TO THE OUTSIDE DIAMETER OF EACH PIPE. SEE DETAIL S-49/SD-2.0.
24. CONTRACTOR SHALL CONFINE WORK HOURS FROM 7:00 AM TO 6:00 PM MONDAY THROUGH FRIDAY UNLESS APPROVED BY UTILITY OWNER, AND TOWN OF ROLESVILLE.
25. CONTRACTOR SHALL PROVIDE TRAFFIC CONTROL, AND ERECT AND MAINTAIN AT ALL TIMES DURING THE PROGRESS OR TEMPORARY SUSPENSION OF WORK, SUITABLE BARRIERS, FENCES, SIGNS OR OTHER ADEQUATE PROTECTION, INCLUDING FLAGMEN AND WATCHMEN AS NECESSARY TO ENSURE THE SAFETY OF THE PUBLIC AS WELL AS THOSE ENGAGED IN THE CONSTRUCTION WORK. CONSTRUCTION SIGNAGE SHALL BE IN ACCORDANCE WITH THE "MANUAL ON UNIFORM TRAFFIC CONTROL DEVICES" (MUTCD) AS SUPPLEMENTED BY THE NCDOT.
26. CONTRACTOR SHALL NOTIFY HOME AND BUSINESS OWNERS IN WRITING AT LEAST 7 DAYS PRIOR TO CONSTRUCTION THAT CONSTRUCTION ACTIVITY WILL TAKE PLACE IN THE VICINITY OF THEIR PROPERTY.
27. IF THE TOWN OF ROLESVILLE OR STATE DOT ALLOWS EXCAVATED MATERIAL STORAGE ON PAVEMENT, A LAYER OF COARSE SAND, SCREENINGS OR ACCEPTABLE ALTERNATIVE SHALL BE PLACED ON THE PAVEMENT PRIOR TO DEPOSITION OF EXCAVATED MATERIAL.
28. LANE CLOSURES OR CONSTRUCTION SHALL NOT OCCUR ON OPPOSITE SIDES OF A STREET OR INTERSECTION SIMULTANEOUSLY.
29. ALL TRAFFIC SHALL BE RESTORED TO TWO-WAY TRAFFIC AT THE END OF EACH WORK DAY.
30. CONTRACTOR SHALL OBTAIN ALL NECESSARY PERMITS FROM TOWN OF ROLESVILLE INCLUDING BUT NOT LIMITED TO STREET CUT PERMITS AND LANE CLOSURE PERMITS, AT LEAST 72 HOURS PRIOR TO COMMENCEMENT OF WORK.
31. PAVEMENT CUTS SHALL BE SAW CUT ALONG A STRAIGHT CONTINUOUS EDGE.
32. CONTRACTOR SHALL FURNISH AND INSTALL SHEETING REQUIRED FOR THE INSTALLATION OF THE UTILITY. EXCAVATIONS SHALL BE KEPT WITHIN THE DESIGNATED EASEMENT AND RIGHT-OF-WAY WIDTHS. EXCAVATION WITH PAVED AREAS SHALL BE KEPT TO A MINIMUM. SHEETING SHALL BE INSTALLED AS REQUIRED TO PROTECT EXISTING UTILITIES.
33. CONTRACTOR SHALL REMOVE AND REINSTALL EXISTING FENCES AS REQUIRED FOR CONSTRUCTION. ADDITIONAL FENCE MATERIALS REQUIRED SHALL BE PROVIDED BY CONTRACTOR AT NO ADDITIONAL COST TO THE OWNER.
34. CONCRETE CURBS AND DRIVEWAYS SHALL BE REPLACED TO THE FIRST EXPANSION JOINT BEYOND THE TRENCH EXCAVATION LIMITS AND TO THE FULL WIDTH. CURBS AND CONCRETE DRIVEWAYS SHALL MATCH EXISTING.
35. EMERGENCY VEHICLE ACCESS AND ACCESS TO FIRE HYDRANTS SHALL BE MAINTAINED AT ALL TIMES.

RALEIGH STANDARD UTILITY NOTES:

- 1. ALL MATERIALS & CONSTRUCTION METHODS SHALL BE IN ACCORDANCE WITH CITY OF RALEIGH DESIGN STANDARDS, DETAILS & SPECIFICATIONS (REFERENCE: CORFUD HANDBOOK, CURRENT EDITION).
2. ANY NECESSARY FIELD REVISIONS ARE SUBJECT TO REVIEW & APPROVAL OF AN AMENDED PLAN &/OR PROFILE BY RALEIGH WATER PRIOR TO CONSTRUCTION.
3. CONTRACTOR SHALL MAINTAIN CONTINUOUS WATER & SEWER SERVICE TO EXISTING RESIDENCES & BUSINESSES THROUGHOUT CONSTRUCTION OF PROJECT. ANY NECESSARY SERVICE INTERRUPTIONS SHALL BE PRECEDED BY A 24 HOUR ADVANCE NOTICE TO RALEIGH WATER.
4. INSTALL 4" PVC SEWER SERVICES @ 1.0% MINIMUM GRADE WITH CLEANOUTS LOCATED AT ROW OR EASEMENT LINE & SPACED EVERY 75 LINEAR FEET MAXIMUM.
5. ALL ENVIRONMENTAL PERMITS APPLICABLE TO THE PROJECT MUST BE OBTAINED FROM NCDEQ, USACE &/OR FEMA FOR ANY RIPARIAN BUFFER, WETLAND &/OR FLOODPLAIN IMPACTS (RESPECTIVELY) PRIOR TO CONSTRUCTION.
6. WATER AND SEWER WORK IN STREETS SHALL BE BACKFILLED, TOPPED WITH GRAVEL, AND COMPACTED DAILY AS WORK PROGRESSES TO CONTROL EROSION. EROSION CONTROL MEASURES SHALL BE USED AT CURB INLETS TO PREVENT RUNOFF FROM ENTERING THE STORM SEWER SYSTEM WHERE NEEDED.
7. ANY STORM DRAIN PIPE DAMAGED DURING THE INSTALLATION OF NEW SEWER AND/OR WATER LINES SHALL BE REPAIRED WITH A MINIMUM OF 10' OF REPLACEMENT PIPE OF THE SAME MATERIAL AS THE PIPE DAMAGED. ALL DAMAGED PIPE SHALL BE REPLACED.

EROSION CONTROL NOTES:

- 1. CONTRACTOR SHALL SCHEDULE AN ON-SITE MEETING WITH ENGINEER, RALEIGH WATER INSPECTOR, AND TOWN OF ROLESVILLE PUBLIC WORKS DEPARTMENT AS FOLLOWS:
A. PRIOR TO BEGINNING ANY LAND DISTURBING ACTIVITY AND BEFORE INSTALLATION OF EROSION CONTROL MEASURES.
B. AFTER INSTALLATION OF PERMANENT AND TEMPORARY EROSION CONTROL MEASURES, BUT PRIOR TO CLEARING AND GRADING.
C. AFTER SITE RESTORATION AND INSTALLATION OF PERMANENT EROSION CONTROL MEASURES, INCLUDING GROUND COVER, BUT PRIOR TO FINAL COMPLETION.
2. PER NPDES REQUIREMENTS, A RAIN GAUGE, SELF-INSPECTIONS RECORDS, PERMIT, AND S&E PLAN ARE REQUIRED TO BE MAINTAINED ON SITE AND ACCESSIBLE DURING INSPECTION. IT IS RECOMMENDED THAT THESE ITEMS BE PLACED IN A PERMITS BOX AT THE BEGINNING OR ENTRANCE OF PROJECT.
3. ALL EROSION CONTROL DEVICES SHALL CONFORM WITH THE NORTH CAROLINA EROSION AND SEDIMENT CONTROL PLANNING AND DESIGN MANUAL AND GENERAL PERMIT NCG01.
4. THE ESCAPE OF SEDIMENT FROM THE SEWER LINE ALIGNMENT SHALL BE PREVENTED BY THE INSTALLATION OF EROSION CONTROL MEASURES AND PRACTICES PRIOR TO CONSTRUCTION.
5. CONTRACTOR SHALL UTILIZE A SILT BAG TO DE-WATER TRENCHES AND PITS DURING CONSTRUCTION.
6. CONTRACTOR SHALL USE EROSION CONTROL DEVICES SHOWN AND ANY ADDITIONAL DEVICES NECESSARY TO CONTROL EROSION AND/OR OFFSITE SEDIMENTATION.
7. ALL EROSION CONTROL DEVICES SHALL BE PROPERLY MAINTAINED DURING ALL PHASES OF CONSTRUCTION UNTIL THE COMPLETION OF ALL CONSTRUCTION ACTIVITIES AND ALL DISTURBED AREAS HAVE BEEN STABILIZED.
8. ALL EROSION AND SEDIMENT CONTROL DEVICES SHALL BE INSPECTED EVERY SEVEN DAYS OR AFTER EACH RAINFALL EVENT THAT EXCEEDS ONE INCH. DAMAGED OR INEFFECTIVE DEVICES SHALL BE REPAIRED OR REPLACED, AS NECESSARY. ALL ESC MEASURES SHALL BE MAINTAINED AS SPECIFIED IN THE CONSTRUCTION PLANS.
9. THE CONTRACTOR SHALL CONDUCT SELF-INSPECTIONS OF THE EROSION AND SEDIMENTATION CONTROL MEASURES AND COMPLETE THE FOLLOWING COMBINED SELF-INSPECTION FORM FOUND ON THE DEMLR WEBSITE
https://files.nc.gov/ncdeq/energy%20mineral%20and%20land%20resources/
stormwater/npdes%20general%20permits/demlr-csw-monitoring-form-rev-august-8--2019.pdf . TWELVE MONTHS OF COMPLETE INSPECTION FORMS SHALL BE KEPT ON-SITE AND AVAILABLE FOR INSPECTION AT ALL TIMES. IT IS RECOMMENDED A COPY BE KEPT IN A PERMITS BOX.
10. TEMPORARY STABILIZATION SHALL BE PROVIDED AT THE END OF EACH WORK DAY TO DISTURBED AREAS.
11. CONTRACTOR SHALL SEED, FERTILIZE, AND MULCH ALL DISTURBED AREAS WITHIN 14 CALENDAR DAYS, OR SOONER AS OUTLINED BY NPDES GROUND STABILIZATION TABLE LOCATED ON ED-2.0. FOR ANY CRITICAL AREA OR AREAS WITH A SLOPE GREATER THAN 2:1, ROLLED EROSION CONTROL PRODUCTS SHALL BE UTILIZED TO AID IN SURFACE STABILIZATION. CRITICAL AREAS SUCH AS STEEP SLOPES, WETLANDS OR FLOOD AREAS SHALL BE STABILIZED IMMEDIATELY UPON COMPLETION OF PIPE INSTALLATION. ADDITIONALLY, CONTRACTOR SHALL IMMEDIATELY STABILIZE GRADING CUT SECTIONS SHOWN ON SS-1.4 UPON COMPETITION OF GRADING ACTIVITIES.
12. CONTRACTOR SHALL PROVIDE A CONSTRUCTION ENTRANCE AND ADDITIONAL EROSION CONTROL DEVICES AS NEEDED, TO BE IMMEDIATELY INSTALLED, FOR ANY MATERIAL LAY DOWN, STAGING AREA, EXCAVATED MATERIAL STORAGE OR ANY OTHER AREAS DISTURBED BY CONSTRUCTION.
13. THE ANGLE FOR GRADED SLOPES AND FILLS SHALL BE NO GREATER THAN THE ANGLE THAT CAN BE RETAINED BY VEGETATIVE COVER OR OTHER ADEQUATE EROSION-CONTROL DEVICES OR STRUCTURES. IN ANY EVENT, SLOPES LEFT EXPOSED SHALL WITHIN 7 OR 14 CALENDAR DAYS OF COMPLETION OF ANY PHASE OF GRADING, BE PLANTED OR OTHERWISE PROVIDED WITH TEMPORARY GROUND COVER, DEVICES OR STRUCTURES SUFFICIENT TO RESTRAIN EROSION.
14. UPON STABILIZATION OF THE CONSTRUCTION CORRIDOR AND APPROVAL BY ENGINEER, CONTRACTOR SHALL REMOVE AND PROPERLY DISPOSE OF EROSION CONTROL DEVICES.
15. PERMANENT GROUND COVER WILL BE PROVIDED FOR ALL DISTURBED AREAS WITHIN 15 WORKING DAYS OR NO MORE THAN 90 CALENDAR DAYS (WHICHEVER IS SHORTER) FOLLOWING COMPLETION OF CONSTRUCTION.
16. ALONG STREAM BANKS AND/OR WITHIN 10 FEET OF THE ORDINARY WATER LEVEL FOR LARGE CHANNELS, VEGETATION MAY BE CUT TO GROUND LEVEL DURING THE CLEARING PHASE OF THE PROJECT; HOWEVER, NO GRUBBING OR SOIL DISTURBANCE SHALL OCCUR WITHIN THE CORRIDOR UNTIL IMMEDIATELY PRIOR TO PIPE INSTALLATION AND THEN ALL WORK SHALL CONTINUE IN THE LOCATION UNTIL COMPLETE AND RE-STABILIZED.

EROSION CONTROL AND CONSTRUCTION SEQUENCE:

- 1. CERTIFICATE OF COVERAGE (COC) MUST BE OBTAINED BEFORE ANY LAND DISTURBING ACTIVITIES OCCUR. THE COC CAN BE OBTAINED BY FILLING OUT THE ELECTRONIC NOTICE OF INTENT (E-NOI) FORM AT DEQ.NC.GOV/NCG01. A COPY OF THE E&S PERMIT, THE COC, AND A HARD COPY OF THE PLAN MUST BE KEPT ON SITE AND ACCESSIBLE DURING INSPECTION.
2. CONTRACTOR SHALL SCHEDULE A PRE-CONSTRUCTION CONFERENCE WITH THE TOWN OF ROLESVILLE PUBLIC WORKS (919-556-3506), RALEIGH WATER INSPECTION DEPARTMENT, AND WAKE COUNTY ENVIRONMENTAL CONSULTANT. NOTIFICATION OF THE MEETING SHALL BE A MINIMUM OF 7 DAYS PRIOR TO BEGINNING LAND DISTURBING ACTIVITIES.
3. OBTAIN A LAND DISTURBING PERMIT FROM WAKE COUNTY.
4. CONFIRM LOCATIONS OF AND CONSTRUCT OR INSTALL NECESSARY EROSION CONTROL DEVICES AS INDICATED ON THE DRAWINGS. INSTALL ALL OTHER NECESSARY EROSION CONTROL MEASURES WHETHER OR NOT INDICATED ON THE DRAWINGS IN ACCORDANCE WITH STANDARD DETAILS AND SPECIFICATIONS. LIMIT CLEARING AND LAND DISTURBING ACTIVITY TO ONLY THE AREA NECESSARY TO INSTALL THE PERMITTED MEASURES.
5. CONTRACTOR SHALL SCHEDULE AN ONSITE INSPECTION BY THE WAKE COUNTY ENVIRONMENTAL CONSULTANT. UPON SUCCESSFUL ONSITE MEETING, OBTAIN A CERTIFICATE OF COMPLIANCE FROM WAKE COUNTY.
6. BEGIN CONSTRUCTION AND INSTALLATION OF INFRASTRUCTURE. DEPENDING ON CONSTRUCTION STAFFING, OPERATIONS MAY OCCUR IN PARALLEL. LAND DISTURBING OPERATIONS INCLUDE:
6.1. LINEAR PIPE LINE INSTALLATION
6.2. GRADING
7. CONTRACTOR SHALL USE SILT BAGS AS NECESSARY FOR DEWATERING OF UTILITY TRENCHES (SEE SW-20.04/ED-1.0). SILT BAGS SHALL BE CONTINUOUSLY MONITORED DURING OPERATIONS.
8. STOCKPILED FILL MATERIAL, IF NOT REMOVED FROM SITE, SHALL BE PROTECTED FROM SEDIMENTATION AND RUNOFF BY COVERING OR INSTALLING EROSION CONTROL MATTING.
9. GRADED AREAS MUST BE STABILIZED UPON COMPLETION WITH TEMPORARY SEEDING AND ROLLED EROSION CONTROL MATTING WITHIN 7 DAYS.
10. BACKFILL AND ESTABLISH FINISH GRADES AS QUICKLY AS POSSIBLE AFTER PIPES HAVE BEEN INSTALLED. CONTRACTOR SHALL APPLY TEMPORARY SEEDING OVER BACKFILLED AREAS AT THE END OF EACH WORK DAY.
11. ALL EROSION AND SEDIMENTATION CONTROL MEASURES SHALL BE INSPECTED WEEKLY AND AFTER EACH RAINFALL EVENT ≥ 1 INCH. NEEDED REPAIRS SHALL BE MADE IMMEDIATELY.
12. TO FACILITATE IN CLEANUP OF PAVED SURFACES, A LAYER OF SAND, SCREENINGS, OR FINES WILL BE PLACED BEFORE DEPOSITION OF ANY EXCAVATED MATERIAL OR USE BY EQUIPMENT/VEHICLES ASSOCIATED WITH THE PROJECT.
13. ONCE CONSTRUCTION ACTIVITY IN COMPLETE FOR EACH AREA, CONTRACTOR SHALL APPLY PERMANENT SOIL VEGETATION WITH PERMANENT SEEDING, FERTILIZER, MULCH AND TACK.
14. SITE MUST BE STABILIZED PRIOR TO SCHEDULING FOR FINAL APPROVAL. GRASS UTILIZED AS PERMANENT GROUND COVER MUST BE AT A MOWABLE HEIGHT THAT GENERALLY PROVIDES AT LEAST 80% COVERAGE THROUGHOUT THE SITE, WITH NO LARGE BARE PATCHES OR EVIDENCE OF EROSION.
15. WHEN CONSTRUCTION ACTIVITIES ARE COMPLETE AND ALL AREAS ARE STABILIZED, THE CONTRACTOR SHALL CONTACT THE WAKE COUNTY ENVIRONMENTAL CONSULTANT FOR A SITE INSPECTION.
16. CONTRACTOR CAN REQUEST FINAL INSPECTION WITH CITY INSPECTOR THROUGH THE PERMIT AND DEVELOPMENT PORTAL (SEE LINK ABOVE).
17. 30 DAYS AFTER PROJECT INSPECTOR OR ENGINEER HAS DETERMINED THAT FINAL SITE HAS BEEN ADEQUATELY STABILIZED WITH PERMANENT SOIL VEGETATION, CONTRACTOR SHALL RETURN TO THE SITE AND REMOVE ALL TEMPORARY MEASURES. CONTRACTOR SHALL INSTALL PERMANENT STABILIZATION TO ALL AREAS DISTURBED BY THE TEMPORARY MEASURES.
18. WHEN THE PROJECT IS COMPLETE AND VEGETATION IS ESTABLISHED, THE CONTRACTOR SHALL CONTACT WAKE COUNTY ENVIRONMENTAL CONSULTANT TO OBTAIN A CERTIFICATE OF COMPLETION.

TRANSPORTATION NOTES:

- 1. ALL SIGNAGE SHALL ADHERE TO MUTCD STANDARDS AND SPECIFICATIONS.
2. IF AN APPROVAL FOR A TRAFFIC CONTROL AND PEDESTRIAN ROUTING SETUP FOR WATER AND SEWER INSTALLATION IS REQUESTED PRIOR TO THE INSTALLATION, PLEASE SEND A PLAN TO RIGHTOFWAYSERVICES@RALEIGHNC.GOV. PLEASE ALLOW 5 BUSINESS DAYS FOR REVIEW.
3. THE SIDEWALK AND PAVEMENT SHALL BE FREE AND CLEAR OF DEBRIS AT ALL TIMES.
4. ALL SIDEWALKS ARE PUBLIC AND MUST BE ACCESSIBLE TO PEDESTRIANS WHO ARE VISUALLY IMPAIRED AND/OR PEOPLE WITH MOBILITY DISABILITIES. EXISTING AND ALTERNATIVE PEDESTRIAN ROUTES DURING CONSTRUCTION SHALL BE REQUIRED TO BE COMPLIANT WITH THE PUBLIC RIGHTS OF WAY ACCESSIBILITY GUIDELINES (PROWAG), 2010 ADA STANDARDS FOR ACCESSIBLE DESIGN AND THE MANUAL ON UNIFORM TRAFFIC CONTROL DEVICES (MUTCD).
5. CONSTRUCTION FENCING SHOULD NOT ENCRUCH INTO THE PUBLIC RIGHT OF WAY. IF IT DOES, IT MUST BE MOVABLE IN CASE ADJUSTMENTS HAVE TO BE MADE. NO DRILLING, BORING OR ANY PERMANENT FASTENING OF THE FENCE IS ALLOWED IN THE PUBLIC RIGHT OF WAY.
6. ACCESS TO ALL DRIVEWAYS AND SIDE STREETS SHALL BE MAINTAINED AT ALL TIMES.

PROJECT NOTES:

- 1. ACCESS SHALL BE ALONG THE EXISTING SEWER EASEMENTS OR WITHIN EXISTING ROAD RIGHTS-OF-WAY AND WORK SHALL BE MAINTAINED WITHIN THE EASEMENTS AND RIGHTS-OF-WAY UNLESS OTHERWISE APPROVED BY THE INDIVIDUAL PROPERTY OWNERS AND/OR THE ENGINEER. THE CONTRACTOR SHALL BE RESPONSIBLE FOR NEGOTIATING WITH PROPERTY OWNERS FOR SUCH ALTERNATE ACCESS AND SHALL PAY ANY AND ALL COSTS ASSOCIATED WITH SUCH ALTERNATE ACCESS AS SPECIFIED ABOVE. ALL SUCH NEGOTIATIONS WITH PROPERTY OWNERS SHALL BE IN WRITING, AND COPIES OF THE AGREEMENTS SHALL BE SUBMITTED TO THE ENGINEER PRIOR TO USING THE ACCESS.
2. TRAFFIC CONTROL DETAILS, DRAWINGS, OR SPECIFICATIONS ARE NOT INTENDED TO ADDRESS EVERY POSSIBLE SITUATION.
3. STREET RIGHTS-OF-WAY ARE SHOWN. CONTRACTOR SHALL CONFINE WORK WITHIN CITY EASEMENTS. CONTRACTOR SHALL OBTAIN ADDITIONAL CONSTRUCTION EASEMENTS IF NEEDED TO COMPLETE WORK.
4. ALL NON-FERROUS PIPES SHALL BE INSTALLED WITH TRACER WIRE AND WARNING TAPE. TERMINATE EACH END OF TRACER WIRE AT VALVE BOX OR MANHOLE. SEE DETAILS FOR INSTALLATION.
5. CONTRACTOR SHALL PERFORM SITE RESTORATION AS CONSTRUCTION PROGRESSES.
6. THE CONTRACTOR IS RESPONSIBLE FOR HANDLING AND ACCOMMODATING ALL EXISTING WASTEWATER FLOWS DURING THE WORK. THE CONTRACTOR WILL BE REQUIRED TO SUBMIT FOR APPROVAL BY THE ENGINEER AND RALEIGH WATER, A DETAILED PLAN OF THE METHOD THE CONTRACTOR PROPOSES TO MAINTAIN EXISTING FLOW DURING CONSTRUCTION. WHEN BYPASS PUMPING IS USED, AN IDENTICAL STANDBY PUMP(S) SHALL BE ON SITE IN THE EVENT OF FAILURE OF THE PRIMARY PUMP(S).
7. BYPASS PLAN SEALED BY A NC PROFESSIONAL ENGINEER MUST BE SUBMITTED TO RALEIGH WATER FOR REVIEW PRIOR TO PUMPING OPERATIONS. PUMPS SHOULD BE SIZED TO HANDLE THE PEAK DAILY FLOW (2.5 TIMES THE AVERAGE DAILY FLOW) FOR THE LINE OR AREA OF WORK. THE CONTRACTOR SHALL SECURE PUMPS FROM A PUMP SUPPLIER ACCORDING TO THE PROVIDED FLOW INFORMATION. PUMPING OPERATIONS MUST BE MONITORED 24 HOURS A DAY FOR EACH DAY OF THE PUMPING OPERATION BY QUALIFIED PERSONNEL IN ORDER TO RESPOND TO PROBLEMS OR FAILURES. 100% REDUNDANCY IS REQUIRED FOR PUMPING OPERATIONS. IN ADDITION, BACK UP PUMPS ARE TO BE CONNECTED TO THE BYPASS FORCE MAIN TO FACILITATE IMMEDIATE USE UPON FAILURE OF THE PRIMARY PUMPS. SEE SHEET C-1.0 FOR SUGGESTED SEWER BYPASS PUMPING PLAN.
8. IF, AT ANY TIME DURING CONSTRUCTION, EFFLUENT FROM THE EXISTING SEWER IS NOT FULLY CONTAINED BY THE BYPASS SYSTEM, SERVICE WILL BE RESTORED AND WORK SHALL BE SUSPENDED UNTIL THE PROBLEM IS RESOLVED TO THE SATISFACTION OF THE ENGINEER AND RALEIGH WATER. THIS INCLUDES WASTEWATER FLOWING INTO TRENCHES DURING EXCAVATION WORK. SEWER SYSTEM OVERFLOWS WILL NOT BE TOLERATED. ALL FINES IMPOSED ON THE DEVELOPER OR RALEIGH WATER AND ASSOCIATED WITH OVERFLOWS CAUSED BY THE CONTRACTOR'S WORK SHALL BE PAID BY THE CONTRACTOR.
9. CONTRACTOR SHALL MAKE TEMPORARY TIE-INS, IF NEEDED, AT THE END OF EACH WORK DAY. OVERNIGHT BYPASS PUMPING IS NOT ALLOWED WITHOUT WRITTEN APPROVAL BY THE OWNER.
10. CONTRACTOR SHALL RECONNECT SANITARY SEWER SERVICES AT THE END OF EACH WORK DAY. THE PERMANENT SANITARY SEWER CONNECTION SHALL BE MADE IN ACCORDANCE TO CITY OF RALEIGH DETAIL 30A, LOCATED ON SHEET SD-2.0.

URBAN FORESTRY NOTES:

- 1. CONTRACTOR SHALL INSTALL REQUIRED TREE PROTECTION FENCE AS SHOWN ON DRAWINGS AND HAVE IT INSPECTED BY TOWN STAFF BEFORE PROCEEDING WITH ADDITIONAL WORK.
2. THE CONTRACTOR SHALL CLEAR, GRUB, AND REMOVE ALL TREES WITHIN LIMITS OF DISTURBANCE.
3. REFRAIN FROM ADDITIONAL CONSTRUCTION ACTIVITIES ON CITY-OWNED OR CONTROLLED EASEMENT UNTIL A SATISFACTORY INSPECTION HAS BEEN COMPLETED BY THE TOWN OF THE REQUIRED TREE PROTECTION FENCING AS APPROVED. DISTURBANCE WITHIN THE REQUIRED TREE PROTECTION AREAS WILL RESULT IN THE ISSUANCE OF A STOP WORK ORDER AND MAY REQUIRE MITIGATION INCLUDING BUT NOT LIMITED TO MONETARY PENALTIES, PRUNING, TREE REMOVAL AND REPLANTING AS DETERMINED BY THE TOWN.
4. ADDITIONAL TREES MAY BE REQUIRED TO BE REMOVED ON CITY-OWNED OR CONTROLLED EASEMENT AT THE DISCRETION OF THE TOWN.

NOTE: ALL CONSTRUCTION SHALL ADHERE TO CITY OF RALEIGH STANDARDS AND SPECIFICATIONS
CITY OF RALEIGH - PLANS AUTHORIZED FOR CONSTRUCTION
Plans for the proposed use have been reviewed for general compliance with applicable codes. This limited review, and authorization for construction is not to be considered to represent total compliance with all legal requirements for development and construction. The property owner, design consultants, and contractors are each responsible for compliance with all applicable City, State and Federal laws. This specific authorization below is not a permit, nor shall it be construed to permit any violation of City, State or Federal Law. All construction must be in accordance with all Local, State, and Federal Rules and Regulations. This approval of this electronic document is only valid if the document has not been modified and the digital signature below is valid.
City of Raleigh Development Approval

Professional Engineer Seal for Brian J.P. Oschwald, No. 038689. Highfill Infrastructure Engineering, P.C. 2703 Jones Franklin Rd, Suite 201, Cary, NC 27518. Tel 919-481-4342, Fax 919-882-9762, www.hiepc.com, Firm License No. C-2586. Engineering is our profession. Service is our passion. WALLBROOK OFFSITE UTILITY IMPROVEMENTS, WALLBROOK LANDCO, ROLESVILLE, NC. GENERAL NOTES. PROJECT NO. CSE2201, C-0.0.

PRELIMINARY DESIGN NOT RELEASED FOR CONSTRUCTION

CD 22-06

LEGEND		
SYMBOL (NEW)	SYMBOL (EX.)	DESCRIPTION
		UTILITY PEDESTAL (SIZE/SHAPE VARIES)
		TREE/SHRUB (DIA. & TYPE SOMETIMES NOTED)
		SEWER CLEAN-OUT
		CONTOUR
		SPOT ELEVATION
		WOODS LINE, CLEARING LIMIT
		SEWER, STORMWATER, & FIBER OPTIC MH
		CATCH BASIN/GRILL BASIN
		WELL
		POWER OR TELEPHONE POLE
		FIRE HYDRANT ASSEMBLY
		GATE VALVE
		BALL VALVE
		FLOODWAY BOUNDARY
		UNDERGROUND / OVERHEAD POWER
		UNDERGROUND TELEPHONE
		OVERHEAD TELEPHONE
		GAS LINE
		WATER LINE
		SEWER LINE
		SEWER FORCE MAIN
		STORMWATER PIPE
		UNDERGROUND FIBER OPTIC LINE
		FENCE
		GUARD RAIL
		PROPERTY LINE
		PERMANENT EASEMENT OR R/W
		STRUCTURE OUTLINE (SHAPES VARY)
		TEMPORARY BENCH MARK
		WATER METER
		SEWER ABANDONMENT
		LIGHT POLE
		PROPERTY OR R/W MONUMENT
		GUY WIRE
		SEWER REMOVAL
		CASING AND CARRIER PIPE
		MAILBOX
		TEMPORARY CONSTRUCTION EASEMENT
		WETLANDS BOUNDARY
		SUBSURFACE TEST BORE
		ITEM TO BE REMOVED
		ASPHALT/CONCRETE REMOVAL & RESTORATION
		LIMITS OF DISTURBANCE LINE
		CRITICAL ROOT ZONE
		TREE CONSERVATION AREA LINE
		PERMIT/RECORD BOX LOCATION
		CONCRETE WASHOUT
		SILT FENCE
		TREE PROTECTION FENCE
		COMBINATION SILT FENCE & TREE PROTECTION FENCE
		SILT FENCE OUTLET
		PIPE INLET PROTECTION
		CHECK DAM
		INLET PROTECTION
		WATTLE
		EROSION CONTROL MATTING
		TEMPORARY CONSTRUCTION ENTRANCE
		RIP-RAP BANK STABILIZATION
		STREAM STABILIZATION



1 SHEET LAYOUT
SCALE: 1" = 200'

ABBREVIATIONS:

AWWA - AMERICAN WATER WORKS ASSOCIATION
 CL - CENTERLINE
 CB - CATCH BASIN
 CMP - CORRUGATED METAL PIPE
 CONC - CONCRETE
 CPP - CORRUGATED PLASTIC PIPE
 CT - COURT
 DI - DUCTILE IRON
 DIP - DUCTILE IRON PIPE
 DR - DRIVE
 EX - EXISTING
 EOP - EDGE OF PAVEMENT

FM - FORCE MAIN
 GV - GATE VALVE
 HDPE - HIGH DENSITY POLYETHYLENE
 INV - INVERT
 IP - IRON PIPE
 LSE - LANDSCAPE EASEMENT
 LF - LINEAR FEET
 L.O.D - LIMITS OF DISTURBANCE
 MIN - MINIMUM
 MH - MANHOLE
 MJ - MECHANICAL JOINT
 NIC - NOT IN CONTRACT
 OC - ON CENTER
 NTS - NOT TO SCALE
 PE - PLAIN END

PJ - PUSH-ON JOINT
 PL - PROPERTY LINE
 PP - POWER POLE
 PSI - POUNDS PER SQUARE INCH
 PV - PLUG VALVE
 PVC - POLYVINYL CHLORIDE
 PVMT - PAVEMENT
 R/W or ROW - RIGHT-OF-WAY
 R or RAD - RADIUS
 RCP - REINFORCED CONCRETE PIPE
 REQ'D - REQUIRED
 RD - ROAD
 RJ - RESTRAINED JOINT
 STA - STATION
 SR - SECONDARY ROAD (STATE)

THK - THICK
 TOS - TOP OF SLAB
 TS&V - TAPPING SLEEVE AND VALVE
 TYP. - TYPICAL
 U/G - UNDERGROUND
 U.N.O. - UNLESS NOTED OTHERWISE
 UT - UNDERGROUND TELEPHONE
 W/ - WITH
 WL - WATER LINE
 WWF - WELDED WIRE FABRIC OR FENCE
 # or LB - POUNDS
 5/SD-1 - DETAIL CROSS-REFERENCE (DETAIL 5 ON SHEET SD-1 IN THIS EXAMPLE)

PROJECT SPECIFICATIONS

PART 1 - GENERAL

- CONTRACTOR SHALL COMPLY WITH CITY OF RALEIGH DESIGN STANDARDS.
- SHOP DRAWINGS: SUBMIT SHOP DRAWINGS FOR GRAVITY SEWER PIPE, MANHOLES, PAVEMENT, AND ALL OTHER MATERIALS.
- RECORD DRAWINGS: SUBMIT RED-LINED RECORD OF CONSTRUCTION DRAWINGS AND COPIES OF PRESSURE TESTING.
- WARRANTY: THE CONTRACTOR WARRANTS THE GRAVITY SEWER AND INSTALLATION WILL BE FREE FROM DEFECTS IN MATERIAL AND WORKMANSHIP FOR ONE YEAR FROM INSTALLATION.
- INSTALL ALL GRAVITY SEWER AND MANHOLES IN ACCORDANCE WITH MANUFACTURER'S INSTRUCTIONS.
- CONTRACTOR SHALL COORDINATE WITH THE CITY OF RALEIGH TO SCHEDULE SPECIAL INSPECTIONS.

PART 2 - PRODUCTS

1. POLYVINYL CHLORIDE (PVC) GRAVITY PIPE:

- A.GENERAL:**
- ALL PVC PIPE SHALL BE DESIGNED IN ACCORDANCE WITH AWWA M23 PVC PIPE - DESIGN AND INSTALLATION AND THE UNIBELL HANDBOOK OF PVC PIPE DESIGN AND CONSTRUCTION BY THE PVC PIPE ASSOCIATION.
 - PVC MATERIALS SHALL COMPLY WITH ASTM D1784 AND D3034.
 - SEE DETAIL S-5 ON SHEET SD-1.0 FOR TRENCH BEDDING REQUIREMENTS.
- B.SEWER MAINS:**
- PIPE SIZE AND SDR SHALL BE AS SHOWN ON THE DRAWINGS.
 - PIPE SHALL HAVE AN INTEGRAL ELASTOMERIC-GASKET BELL END. GASKETS SHALL BE IN CONFORMANCE WITH ASTM F477.
 - NOMINAL PIPE LENGTH SHALL BE A MINIMUM OF 13 FEET.
- C.SEWER SERVICES:**
- PIPE AND FITTINGS SHALL BE SCHEDULE 40 OR 80 AS SPECIFIED ON THE DRAWINGS.
 - SCHEDULE 40 FITTINGS SHALL BE MANUFACTURED IN ACCORDANCE WITH ASTM D2466. SCHEDULE 80 FITTINGS SHALL BE MANUFACTURED IN ACCORDANCE WITH ASTM D2467.
 - JOINTS SHALL BE SOLVENT CEMENT WELD. SOLVENT CEMENT SHALL BE IN ACCORDANCE WITH ASTM D2564. JOINTS SHALL BE MADE IN STRICT ACCORDANCE WITH THE PIPE MANUFACTURER'S RECOMMENDATIONS INCLUDING NECESSARY FIELD CUTTINGS, SANDING OF PIPE ENDS, JOINT SUPPORT DURING SETTING PERIOD, ETC.

2. PRECAST CONCRETE MANHOLES:

A.PROVIDE MANHOLES MADE OF PRECAST CONCRETE SECTIONS IN CONFORMANCE WITH ASTM C478, THE DRAWINGS, THE CITY OF RALEIGH PUBLIC UTILITIES HANDBOOK, NC DEPARTMENT OF TRANSPORTATION, AND THE REQUIREMENTS THAT FOLLOW:

- B.GENERAL:**
- PRECAST CONCRETE MANHOLES SHALL BE AS MANUFACTURED BY TINDALL CONCRETE PRODUCTS, INC., ADAMS CONCRETE, HANSON PIPE AND PRECAST, LINDSAY PRECAST, OLDCASTLE, OR APPROVED EQUAL.

C.COATINGS:

WHEN APPLYING COATINGS TO NEW MANHOLES, COATINGS WILL BE APPLIED ABOVE GROUND (BEFORE MANHOLE COMPONENTS ARE INSTALLED). AREAS TO BE COATED SHALL MEET COATING MANUFACTURER REQUIREMENTS FOR SURFACE PREPARATION. JOINTS SHALL BE COATED AFTER MANHOLE INSTALLATION.

D.EPOXY:

- THE EPOXY SYSTEM SHALL BE A SPRAY APPLIED, TWO COMPONENT, 100% SOLIDS, SOLVENT-FREE EPOXY DEVELOPED SPECIFICALLY FOR USE IN THE WASTEWATER ENVIRONMENT. EPOXY LINER SHALL BE RAVEN 405, MANUFACTURED BY RAVEN LINING SYSTEMS; DURA-PLATE 5900 OR 6100 MANUFACTURED BY SHERWIN-WILLIAMS; PERMA-SHIELD H₂S SERIES 434 AND PERMA-GLAZE SERIES 435, MANUFACTURED BY TMEC, OR APPROVED EQUAL.
- APPLICATION PROCEDURES FOR THE EPOXY LINING SYSTEM SHALL BE IN ACCORDANCE WITH THE MANUFACTURER'S RECOMMENDATIONS, INCLUDING MATERIALS HANDLING, MIXING, ENVIRONMENTAL CONTROLS DURING APPLICATION, SAFETY AND SPRAY EQUIPMENT.
- THE EPOXY LINER, WHEN CURED, SHALL HAVE THE FOLLOWING MINIMUM CHARACTERISTICS MEASURED BY THE APPLICABLE ASTM STANDARDS REFERENCED HEREIN:
 - HARDNESS, SHORE D ASTM D-2240 70
 - TENSILE STRENGTH ASTM D-638 >7,000 PSI
 - FLEXURAL STRENGTH ASTM D-790 >10,000 PSI
- WHEN CURED, THE LINING SHALL FORM A CONTINUOUS, TIGHT-FITTING, HARD, IMPERMEABLE SURFACE WHICH IS SUITABLE FOR SEWER SYSTEM SERVICE AND CHEMICALLY RESISTANT TO ANY CHEMICALS OR VAPORS NORMALLY FOUND IN DOMESTIC SEWAGE.
- THE LINING SHALL BE COMPATIBLE WITH THE THERMAL CONDITION OF THE EXISTING SEWER MANHOLE SURFACES. SURFACE TEMPERATURES WILL RANGE FROM 20°F TO 100°F.

E.PRECAST CONCRETE SECTIONS:

- MINIMUM WALL THICKNESS SHALL BE 5-INCHES.
- BASE: CAST MONOLITHICALLY WITHOUT CONSTRUCTION JOINTS OR WITH AN APPROVED PVC WATERSTOP IN THE COLD JOINT BETWEEN THE BASE SLAB AND THE WALLS. MINIMUM THICKNESS OF BASE SHALL BE 6-INCHES.
- THE WIDTH OF THE BASE EXTENSIONS ON EXTENDED BASE MANHOLES SHALL BE NO LESS THAN THE BASE SLAB THICKNESS. EXTENDED BASES SHALL COMPLY WITH THE DETAILS ON DRAWINGS.
- RISER: MINIMUM LAY LENGTH OF 16 INCHES.
- CONE: ECCENTRIC OR CONCENTRIC CONES MAY BE USED ON 8 THROUGH 12-INCH MAINS. CONCENTRIC CONES SHALL BE USED ON ALL 15-INCH AND LARGER MAINS. SHALL BE SIZED TO FIT WITHIN THE MANHOLE ID AND THE TOP AND BOTTOM SURFACES. PROVIDE A FLOAT FINISH FOR EXTERIOR SLAB SURFACE.
- FLAT SLAB TOP: DESIGNED FOR HS-20 TRAFFIC LOADINGS AS DEFINED IN ASTM C890. ITEMS TO BE CAST INTO SPECIAL FLAT SLAB TOPS (I.E. RING, COVER, VENT BASE) SHALL BE SIZED TO FIT WITHIN THE MANHOLE ID AND THE TOP AND BOTTOM SURFACES. PROVIDE A FLOAT FINISH FOR EXTERIOR SLAB SURFACE.
- PRECAST OR CORE HOLES FOR PIPE CONNECTIONS. DIAMETER OF HOLE SHALL NOT EXCEED OUTSIDE DIAMETER OF PIPE BY MORE THAN 3-INCHES.
- LIFTING DEVICES: DEVICES FOR HANDLING PRECAST COMPONENTS SHALL BE PROVIDED BY THE PRECAST MANUFACTURER AND COMPLY WITH OSHA STANDARD 1926.704.

F.JOINTS:

- MANUFACTURER IN ACCORDANCE WITH TOLERANCE REQUIREMENTS OF ASTM C 990 FOR BUTYL TYPE JOINTS.
- MINIMIZE NUMBER OF JOINTS. DO NOT USE RISER SECTION FOR MANHOLES UP TO 6 FEET TALL AND NO MORE THAN ONE RISER FOR EACH ADDITIONAL 4 FEET IN HEIGHT.
- FLEXIBLE JOINT SEALANTS: FLEXIBLE JOINT SEALANTS: PREFORMED BUTYL RUBBER BASED SEALANT MATERIAL CONFORMING TO FEDERAL SPECIFICATION SS-S-210A, TYPE B AND ASTM C990.
- EXTERNAL SEAL: POLYETHYLENE BACKED FLAT BUTYL RUBBER SHEET NO LESS THAN 1/16-INCH THICK AND 8-INCHES WIDE.

G.INVERTS:

- BRICK AND MORTAR OR PRECAST CONCRETE INVERT CONSTRUCTED TO THE WIDTH OF THE EFFLUENT PIPE.
- FORM AND FINISH INVERT CHANNEL TO PROVIDE A CONSISTENT SLOPE FROM INLET(S) TO OUTLET(S) UP TO 6-INCHES.
- CHANNEL WALLS SHALL BE FORMED TO THE SPRINGLINE OF THE OUTLET PIPE DIAMETER.
- FINISH BENCHES AT 60 DEGREES TO MANHOLE WALLS. PROVIDE A 1/4-INCH RADIUS AT THE EDGE OF BENCH AND TROUGH.

H.FLEXIBLE PIPE CONNECTORS:

- PROVIDE FLEXIBLE CONNECTORS FOR PIPE TO MANHOLE THAT CONFORM TO ASTM C923. LOCATION OF CONNECTORS SHALL VARY FROM DRAWINGS NO MORE THAN 1/2-INCH VERTICALLY AND 5 DEGREES HORIZONTALLY. BOOT SLEEVES SHALL HAVE STAINLESS STEEL EXPANSION BANDS AND PIPE CLAMPS THAT MEET OR EXCEED ASTM C923.

I. STEPS:

- STEPS ARE NOT ALLOWED INSIDE MANHOLES.
- STEPS SHALL BE PROVIDED ON OUTSIDE OF RAISED MANHOLES WHEN TOP ELEVATION IS GREATER THAN THREE (3) FEET ABOVE EXISTING GROUND ELEVATION.

J.SEWER SERVICE:

- PROVIDE PVC WYE SEWER SADDLES FOR SERVICES ON PVC MAINS. SADDLES SHALL BE SOLVENT WELDED AND FASTENED WITH DOUBLE STAINLESS-STEEL BANDS.
- PROVIDE A CAST OR DUCTILE IRON WYE SEWER SADDLE FOR SERVICES ON DUCTILE IRON MAIN. SADDLES SHALL BE "GENECO E40" SEWER SADDLES OR APPROVED EQUAL CONSISTING OF A VIRGIN SBR GASKET COMPOUNDED FOR SEWER SERVICE, A DUCTILE IRON SADDLE CASTING, A 304 STAINLESS-STEEL ADJUSTABLE STRAP FOR FASTENING THE GASKET AND THE SADDLE CASTING TO THE SEWER MAIN, AND A 304 STAINLESS STEEL ADJUSTABLE CIRCLE CLAMP FOR SECURING THE SERVICE LINE INTO THE SBR GASKET.

3. ENCASUREMENT PIPE:

ENCASUREMENT PIPE SHALL BE HIGH STRENGTH SPIRAL WELDED STEEL MEETING ASTM A-252, GRADE 2 STEEL, WITH MINIMUM YIELD STRENGTH OF 35,000 PSI. PIPE LENGTH, SIZE, AND MINIMUM THICKNESS SHALL BE AS INDICATED ON THE DRAWINGS.

B.PIPE SUPPORT:

- PROVIDE PIPE SUPPORTS DESIGNED AND MANUFACTURED FOR THE SUPPORT OF THE CARRIER PIPE SIZE AND MATERIAL TO BE USED WITHIN THE ENCASUREMENT SIZE INDICATED ON DRAWINGS. SUPPORTS SHALL BE DESIGNED TO CARRY THE PIPE AT THE SUPPORT SPACING SPECIFIED AND MEET THE FOLLOWING REQUIREMENTS:
- BAND WIDTH: 8 INCHES FOR PIPES 14 INCHES AND UNDER AND 12 INCHES FOR PIPES 16 INCHES AND OVER.
- BAND AND RISER SHALL BE 14 GAUGE STEEL. RISER SHALL BE CHANNEL SHAPED. BAND WITH RISERS SHALL HAVE A FUSION BONDED PVC COATING OF A MINIMUM 10-MIL THICKNESS. BAND SHALL BE BOLTED TOGETHER WITH STAINLESS STEEL BOLTS, NUTS, AND WASHERS.
- RUNNER SHALL BE A MINIMUM OF 1 INCH WIDE AND NOT MORE THAN 1 INCH SHORTER THAN BANDWIDTH. PROVIDE TWO TOP AND TWO BOTTOM RUNNERS FOR PIPE PIPES 12 INCHES AND UNDER.

C.THE CARRIER PIPE SHALL BE CENTERED WITHIN THE ENCASUREMENT PIPE.

D.PROVIDE MORTARED CASING SEAL ON EACH END OF THE CASING.

NOTE: ALL CONSTRUCTION SHALL ADHERE TO CITY OF RALEIGH STANDARDS AND SPECIFICATIONS

CITY OF RALEIGH - PLANS AUTHORIZED FOR CONSTRUCTION

Plans for the proposed use have been reviewed for general compliance with applicable codes. This limited review, and authorization for construction is not to be considered to represent total compliance with all legal requirements for development and construction. The property owner, design consultants, and contractors are each responsible for compliance with all applicable City, State and Federal laws. This specific authorization below is not a permit, nor shall it be construed to permit any violation of City, State or Federal Law. All construction must be in accordance with all Local, State, and Federal Rules and Regulations. This approval of this electronic document is only valid if the document has not been modified and the digital signature below is valid.

City of Raleigh Development Approval

NO.	DATE	BY	REVISION
1	02/24/22	MWC	3RD SUBMITTAL TO TRC
2	12/28/22	JV	2ND SUBMITTAL TO TRC
3	10/28/22	GDF	90% DESIGN 1ST SUBMITTAL TO TRC



2703 Jones Franklin Rd, Suite 201
 Cary, NC 27518
 Tel 919-481-4342
 Fax 919-882-9762
 www.hiepc.com
 Firm License No. C-2586

Engineering is our profession.
 Service is our passion.

WALLBROOK OFFSITE UTILITY IMPROVEMENTS
 WALLBROOK LANDCO
 ROLESVILLE, NC
 LEGEND, ABBREVIATIONS AND SHEET LAYOUT

PROJECT NO.
 CSE2201

C-0.1

CD 22-06

PRELIMINARY DESIGN NOT RELEASED FOR CONSTRUCTION

PROJECT SPECIFICATIONS

SECTION 3 — EXECUTION

1. GENERAL:

A. PIPE INSTALLATION SHALL MEET THE FOLLOWING GENERAL GUIDELINES:

1. LAY PIPE IN THE PRESENCE OF THE OWNER'S DESIGNATED RESIDENT PROJECT REPRESENTATIVE, UNLESS SPECIFICALLY APPROVED OTHERWISE.
2. HANDLE PIPE AND ACCESSORIES IN ACCORDANCE WITH MANUFACTURER'S RECOMMENDATIONS. TAKE PARTICULAR CARE NOT TO DAMAGE PIPE COATINGS.
3. CAREFULLY INSPECT PIPE IMMEDIATELY PRIOR TO LAYING. DO NOT USE DEFECTIVE PIPE. REPLACE PIPE DAMAGED DURING CONSTRUCTION.
4. LAY PIPE TO GRADE AND ALIGNMENT INDICATED ON THE DRAWINGS.
5. PROVIDE PROPER EQUIPMENT FOR LOWERING PIPE INTO TRENCH.
6. PROVIDE TIGHT CLOSURE PIPE ENDS WHEN WORK IS NOT IN PROGRESS.
7. KEEP PIPE INTERIOR FREE OF FOREIGN MATERIALS.
8. DO NOT LAY PIPE IN WATER OR WHEN THE TRENCH OR WEATHER CONDITIONS ARE UNSUITABLE FOR THE WORK.
9. CLEAN BELL AND SPOIGTS BEFORE JOINING. MAKE JOINTS AND LUBRICATE GASKET IN ACCORDANCE WITH PIPE MANUFACTURER RECOMMENDATION.
10. BLOCK FITTINGS WITH CONCRETE OR RESTRAINED AS INDICATED ON THE DRAWINGS OR AS REQUIRED TO PREVENT MOVEMENT.

B. GRAVITY SEWER PIPE: GRAVITY PIPE INSTALLATION SHALL MEET THE FOLLOWING GENERAL GUIDELINES:

1. LAY PIPE UPGRADE FROM THE LOWER END AND AT THE GRADES AND ALIGNMENT INDICATED ON THE DRAWINGS.
2. LAY SEWER PIPE TO TRUE LINES AND GRADES BY USING LASER BEAM EQUIPMENT OR OTHER ACCEPTABLE MEANS.

C. MANHOLES:

1. SET BASE PLUMB AND LEVEL. IF USING PRECAST INVERTS, THEN ALIGN MANHOLE INVERT WITH PIPE INVERT.
2. SECURE PIPE CONNECTORS TO PIPE IN ACCORDANCE WITH MANUFACTURER'S RECOMMENDATION.
3. CLEAN BELLS AND SPOIGTS OF FOREIGN MATERIAL THAT MAY PREVENT SEALING. UNROLL THE BUTYL SEALANT ROPE DIRECTLY AGAINST BASE OF SPOIGT. DO NOT STRETCH. FOLLOW MANUFACTURER'S INSTRUCTIONS WHEN USING O-RING SEALS.
4. PLUG LIFT HOLES USING A NON-SHRINK GROUT. COVER WITH A BUTYL SEALANT SHEET ON THE OUTSIDE AND SEAL ON THE INSIDE WITH AN APPLICATION OF AN EPOXY GEL 1/8-INCH THICK EXTENDING 2 INCHES BEYOND THE OPENING.
5. SET MANHOLE FRAMES TO GRADE WITH GRADE RINGS IN PAVED AREAS. GRADE RINGS ARE NOT ALLOWABLE FOR MANHOLES LOCATED IN EASEMENTS. SEAL JOINTS BETWEEN CONE, ADJUSTING RINGS, AND MANHOLE FRAME WITH BUTYL SEALANT ROPE AND SHEET. CONCRETE COLLAR AS SHOWN IN DETAIL ON THE DRAWINGS SHALL BE INSTALLED FOR MANHOLES LOCATED IN PAVEMENT.
6. APPLY EXTERNAL SEAL TO THE OUTSIDE OF JOINT.
7. FINISH THE INTERIOR BY FILLING FRACTURES GREATER THAN 1/2-INCH IN LENGTH, WIDTH OR DEPTH WITH A SAND CEMENT MORTAR.
8. CLEAN THE INTERIOR OF THE MANHOLE OF FOREIGN MATTER.

D. SEWER CLEANOUTS:

1. SEWER CLEANOUTS CONNECTED TO DUCTILE IRON PIPE SHALL ALSO BE DUCTILE IRON SEWER PIPE CONFORMING TO THESE SPECIFICATIONS.
2. SEWER CLEANOUTS CONNECTED TO PVC PIPE SHALL ALSO BE PVC SEWER PIPE SCHEDULE 40 CONFORMING TO ASTM-D-3034 LATEST REVISION. USE ELASTOMERIC GASKETS FOR PIPE JOINTS.
3. PVC WYE SEWER SADDLES SHALL BE USED ON NEW PVC PIPE. SADDLES SHALL BE USED ON EXISTING PVC. SOLVENT WELDED TO THE MAIN AND FASTENED WITH DOUBLE STAINLESS STEEL BANDS.
4. CLEANOUTS SHALL BE A MINIMUM OF 4-INCH DIAMETER UNLESS NOTED OTHERWISE ON THE DRAWINGS. PROVIDE SEWER CLEANOUTS WITH SCREW-IN WATERTIGHT CAP. INSTALLATION SHALL BE IN ACCORDANCE WITH THE DETAILS AS SHOWN ON THE DRAWINGS.

E. SERVICE CONNECTIONS:

1. MAKE SERVICE CONNECTIONS IN ACCORDANCE WITH THE STANDARD DETAIL(S) ON THE DRAWINGS.
2. SERVICE CONNECTIONS TO THE MAIN LINES SHALL BE PERPENDICULAR TO THE MAIN LINE TO THE EDGE OF THE RIGHT-OF-WAY OR EASEMENT LINE.
3. FOUR-INCH LINES SHALL HAVE A MINIMUM SLOPE OF 1.0 % AND HAVE CLEANOUTS EVERY 75 FEET AT A MINIMUM IN ADDITION TO A CLEANOUT AT THE RIGHT-OF-WAY LINE OR AT THE EDGE OF THE EASEMENT.
4. SIX-INCH LINES SHALL HAVE A MINIMUM SLOPE OF 0.60 % AND HAVE CLEANOUTS EVERY 100 FEET AT A MINIMUM IN ADDITION TO A CLEANOUT AT THE RIGHT-OF-WAY LINE OR AT THE EDGE OF THE EASEMENT.
5. 6-INCH SERVICE LINES SHALL TIE DIRECTLY INTO A MANHOLE.
6. WYE SEWER SADDLES SHALL BE MADE ONLY WHEN THE SEWER MAIN IS 8-, 10-, OR 12-INCH DIAMETER CONCRETE, DUCTILE IRON, OR PVC SEWER PIPE. THIS TYPE CONNECTION CANNOT BE USED ON TRUSS SEWER PIPE. THE OPENING IN THE SEWER MAIN FOR THE SADDLE SHALL BE CUT WITH A HYDRAULICALLY DRIVEN OR PNEUMATICALLY DRIVEN CIRCULAR TAPPING SAW OF THE SAME NOMINAL DIAMETER AS THE SEWER SERVICE LINE.

2. TESTING:

G. GENERAL

1. CLEAN AND FLUSH PIPE SYSTEM OF FOREIGN MATTER PRIOR TO TESTING.
2. NOTIFY OWNER AND ENGINEER A MINIMUM OF 48 HOURS PRIOR TO TESTING.
3. PERFORM TESTS IN THE PRESENCE OF ENGINEER.
4. LENGTH OF LINE TO BE TESTED AT ONE TIME SHALL BE SUBJECT TO APPROVAL OF ENGINEER.
5. PIPE SECTIONS SHALL NOT BE ACCEPTED AND PLACED INTO SERVICE UNTIL SPECIFIED TEST HAVE BEEN PERFORMED AND APPROVED.
6. REPAIR DEFECTS IN THE PIPE SYSTEM. MAKE REPAIRS TO THE SAME STANDARD AS SPECIFIED FOR THE PIPE SYSTEM.
7. RETEST REPAIRED SECTIONS UNTIL ACCEPTANCE.
8. REPAIR VISIBLE LEAKS REGARDLESS OF THE TEST RESULTS.

H. GRAVITY SEWER MAINS:

1. TEST GRAVITY SEWER BETWEEN MANHOLES USING LOW-PRESSURE AIR. EACH PIPE JOINT/COUPLING SHALL BE INDIVIDUALLY TESTED WITH AN INTERNAL JOINT TESTER FOLLOWING INSTALLATION AND PRIOR TO THE NEXT JOINT/COUPLING OF PIPE BEING INSTALLED. THE JOINT/COUPLING OF PIPE BEING TESTED SHALL BE RETESTED AFTER THE NEXT UPSTREAM JOINT/COUPLING OF PIPE IS TESTED, TO INSURE THAT THE UPSTREAM PIPE CONNECTION HAS NOT CAUSED THE INITIAL PIPE JOINT/COUPLING TO LOSE ITS SEAL.
2. LIGHT TESTING: ENGINEER WILL CHECK FOR DISPLACEMENT OF PIPE AS FOLLOWS:
 - a. A LIGHT WILL BE FLASHED THROUGH THE ENDS OF THE PIPE SECTION BEING TESTED.
 - b. IF THE ILLUMINATED INTERIOR SHOWS MISALIGNMENT, OR OTHER DEFECTS AS DESIGNATED BY ENGINEER, DEFECTS SHALL BE REPAIRED

3. GENERAL:

- a. INFILTRATION SHALL NOT EXCEED 100 GALLONS PER INCH OF DIAMETER, PER MILE OF PIPE, PER 24 HOURS. ENGINEER MAY REQUIRE FLOW MEASUREMENT FOR VERIFICATION OF INFILTRATION
 - b. VERIFY THAT MAXIMUM INFILTRATION RATE SHALL NOT BE SURPASSED BY PERFORMING AN AIR TESTING AS FOLLOWS.
4. LOW PRESSURE AIR TESTING:
- a. AIR TESTING OF SEWER MAINS SHALL CONFORM TO UNI-B-6 AND THE FOLLOWING REQUIREMENTS:
 - b. PERFORM INITIAL AIR TEST WHEN EACH SECTION OF MAIN IS COMPLETE INCLUDING SERVICES TO RIGHT OF WAY. TEST AS CONSTRUCTION PROCEEDS.
 - c. WET INTERIOR SURFACES OF POROUS PIPE MATERIAL PRIOR TO TESTING.

d. SAFETY

- 1) PROVIDE A SUPERINTENDENT WHO HAS EXPERIENCE IN LOW PRESSURE AIR TESTING OF GRAVITY SEWER MAINS.
- 2) FOLLOW SAFETY RECOMMENDATIONS OF AIR TESTING EQUIPMENT MANUFACTURER.
- 3) PROPERLY BRACE SEWER PLUGS DURING TESTING. TEST PLUGS PRIOR TO USE IN AIR TESTING.
- 4) NO ONE SHALL BE ALLOWED IN MANHOLE OR TRENCH WHEN PIPE IS UNDER PRESSURE.
- 5) PRESSURIZING EQUIPMENT SHALL INCLUDE A REGULATOR AND A PRESSURE RELIEF VALVE, WHICH ARE SET NO HIGHER THAN 9 PSIG. MONITOR GAUGES CONTINUOUSLY TO ASSURE THAT THE PRESSURE DOES NOT EXCEED 9 PSIG.

e. EQUIPMENT

- 1) SEWER PLUGS SHALL BE SPECIFICALLY DESIGNED FOR LOW PRESSURE AIR TESTING.
- 2) USE TWO SEPARATE AIR HOSES.
 - i) ONE TO CONNECT THE CONTROL PANEL TO THE SEALED LINE FOR INTRODUCING THE AIR.
 - ii) ONE FROM THE SEALED LINE TO THE CONTROL PANEL TO PROVIDE CONSTANT MONITORING OF THE AIR PRESSURE IN THE LINE.
 - iii) IF PNEUMATIC PLUGS ARE USED A SEPARATE LINE SHALL BE USED TO INFLATE THE PLUGS.
- 3) AS A MINIMUM THE ABOVE GROUND AIR TESTING EQUIPMENT SHALL INCLUDE A SHUTOFF VALVE, PRESSURE REGULATING VALVE, PRESSURE RELIEF VALVE, INPUT PRESSURE GAUGE, AND A CONTINUOUS MONITORING PRESSURE GAUGE HAVING A PRESSURE RANGE FROM 0 TO AT LEAST 10 PSIG.
- 4) CONTINUOUS MONITORING PRESSURE GAUGE SHALL BE AT LEAST 4 INCHES IN DIAMETER WITH MINIMUM DIVISIONS OF 0.10 PSI AND AN ACCURACY OF +/- 0.04 PSI.
- 5) MONITORING GAUGES SHALL BE SUBJECT TO CALIBRATION AS DEEMED NECESSARY.
- 6) AIR USED FOR TESTING SHALL PASS THROUGH A SINGLE ABOVE GROUND CONTROL PANEL.
- 7) INTERNAL JOINT TESTERS SHALL BE MANUFACTURED BY LANSAS PRODUCTS, PLUG-IT PRODUCTS, OR CHERNE INDUSTRIES, INC.

f. TESTING

- 1) GROUNDWATER DETERMINATION: IMMEDIATELY PRIOR TO EACH AIR TEST, DETERMINE GROUNDWATER LEVEL BY A METHOD ACCEPTABLE TO THE ENGINEER. ADJUST PRESSURE USED IN AIR TEST IN ACCORDANCE WITH GROUNDWATER LEVEL.
- 2) APPLY AIR SLOWLY TO THE TEST SECTION UNTIL THE PRESSURE REACHED IS 4.0 PSI PLUS AN ADJUSTMENT OF 0.433 PSI FOR EACH FOOT OF GROUND WATER ABOVE THE CROWN OF THE PIPE. INTERNAL AIR PRESSURE, INCLUDING ADJUSTMENT FOR GROUND WATER, SHOULD NEVER EXCEED 9.0 PSI FOR DUCTILE IRON AND CONCRETE PIPE AND 5.0 PSI FOR FIBERGLASS PIPES. THE CONTRACTOR MAY HAVE TO DEWATER TRENCH TO MAINTAIN GROUND WATER AT OR BELOW CROWN OF FIBERGLASS PIPE WHEN TESTING. COST FOR THIS SHALL BE INCLUDED IN UNIT PRICE FOR PIPE INSTALLATION.
- 3) WHEN THE ABOVE REQUIRED PRESSURE IS REACHED, THROTTLE AIR SUPPLY TO MAINTAIN INTERNAL PRESSURE FOR AT LEAST TWO MINUTES TO PERMIT STABILIZATION.
- 4) WHEN PRESSURE HAS STABILIZED AT REQUIRED PRESSURE, SHUT OFF AIR SUPPLY.
- 5) WHILE OBSERVING THE CONTINUOUS MONITORING PRESSURE GAUGE, DECREASE PRESSURE APPROXIMATELY 0.5 PSI FROM REQUIRED PRESSURE.
- 6) AT THIS READING TIMING SHALL COMMENCE WITH A STOP WATCH AND ALLOWED TO RUN UNTIL PRESSURE HAS DROPPED 1.0 PSI OR ALLOWABLE TIME HAS LAPSED. LINE SHALL BE "ACCEPTABLE" IF THE PRESSURE DROP DOES NOT EXCEED 1 PSIG IN THE TIME PRESCRIBED FOR THE TEST BELOW IN TABLE 1. LOW PRESSURE AIR TESTING FOR GRAVITY SEWER MAINS.
- 7) AIR PRESSURE APPLIED THROUGH THE INTERNAL JOINT TESTERS SHALL BE IN ACCORDANCE WITH ITEM 2) ABOVE.

I. VACUUM TEST EACH MANHOLE IN ACCORDANCE WITH ASTM C1244 AND THE FOLLOWING:

1. NO PERSONNEL SHALL BE ALLOWED IN MANHOLE DURING TESTING.
2. TEST MANHOLE AFTER ASSEMBLY AND PRIOR TO BACKFILLING.
3. PLUG PIPES WITH SUITABLY SIZED AND RATED PNEUMATIC OR MECHANICAL PIPELINE PLUGS. BRACE PLUGS TO PREVENT DISPLACEMENT.
4. POSITION VACUUM TEST HEAD ASSEMBLY TO SEAL AGAINST INTERIOR SURFACE OF THE TOP OF CONE SECTION IN ACCORDANCE WITH MANUFACTURER'S RECOMMENDATION.
5. DRAW VACUUM OF 10 INCHES OF MERCURY ON MANHOLE. SHUT OFF THE VACUUM PUMP AND CLOSE VALVE ON VACUUM LINE.
6. MEASURE TIME FOR VACUUM TO DROP TO 9 INCHES OF MERCURY. MANHOLE SHALL PASS IF TIME MEETS OR EXCEEDS THE FOLLOWING:
MANHOLE I.D. (INCHES) 48 60 72 84 96 120 T-SERIES
SECONDS 60 75 90 105 120 150 105
7. IF MANHOLE FAILS TEST, REMOVE HEAD ASSEMBLY, COAT INTERIOR WITH A SOAP AND WATER SOLUTION, AND REPEAT VACUUM TEST FOR APPROXIMATELY 30 SECONDS. LEAKING AREAS WILL HAVE SOAPY BUBBLES. MAKE NECESSARY REPAIRS TO THE SATISFACTION OF ENGINEER AND REPEAT TEST UNTIL MANHOLE PASSES.

3. CLEANING AND TV INSPECTIONS:

- 1) UPON COMPLETION OF OTHER TESTING, CLEAN ALL NEWLY INSTALLED SEWER MAINS. THIS SHALL INCLUDE ALL SEWER MAIN AND LATERAL CONNECTIONS. THIS CLEANING SHALL MEET THE FOLLOWING REQUIREMENTS:
 - i) 1. THE OWNER'S DESIGNATED RESIDENT PROJECT REPRESENTATIVE SHALL BE PRESENT THROUGHOUT THE CLEANING OPERATIONS.
 - ii) 1. THE SEWER MAINS SHALL BE CLEANED WITH A HIGH-VELOCITY WATER JET. NO DEBRIS OF ANY KIND SHALL BE RELEASED INTO THE SEWER SYSTEM.
- 2) UPON COMPLETION OF CLEANING OPERATIONS, WITHIN 2 HOURS, OWNER SHALL TELEVIEW ALL NEWLY INSTALLED SEWER MAINS.
 - i) CONTRACTOR SHALL COORDINATE CLEANING AND TELEVISION OPERATIONS WITH OWNER TO ENSURE TIME SCHEDULES CAN BE ACHIEVED
 - ii) IF TELEVISION IS NOT PROPERLY COORDINATED, OWNER MAY REQUEST CONTRACTOR TO CLEAN SEWER MAINS AGAIN AT NO ADDITIONAL COST TO THE OWNER.

END OF SECTION

MANHOLE EPOXY LINER NOTES:

1. INTERIOR LININGS FOR EXISTING PRECAST REINFORCED CONCRETE MANHOLES
 - 1.1. EXISTING MANHOLES TO BE LINED FOR PROTECTION FROM CORROSION SHALL BE LINED WITH AN EPOXY SYSTEM SUITABLE FOR WASTEWATER ENVIRONMENTS. THE EPOXY SYSTEM SHALL BE A SPRAY APPLIED, TWO COMPONENT, 100% SOLIDS, SOLVENT-FREE EPOXY DEVELOPED SPECIFICALLY FOR USE IN THE WASTEWATER ENVIRONMENT. EPOXY LINER SHALL BE RAVEN 405, MANUFACTURED BY RAVEN LINING SYSTEMS; DURA-PLATE 5900 OR 6100 MANUFACTURED BY SHERWIN-WILLIAMS; PERMA-SHIELD H2S SERIES 434 AND PERMA-GLAZE SERIES 435, MANUFACTURED BY TNEC, OR APPROVED EQUAL.
2. INTERIOR LININGS FOR NEW PRECAST REINFORCED CONCRETE MANHOLES
 - 2.1. ALL SANITARY SEWER INTERCEPTOR/OUTFALL MANHOLES ON LINES 12-INCHES AND LARGER, SHALL BE POLYMER CONCRETE MANHOLES OR INTERNALLY COATED WITH A POLYUREA/POLYURETHANE COATING. DURAMER 1030 SHALL BE APPLIED IN ONE COAT OF A 20% SOLIDS, DEEPLY PENETRATING, DUAL-COMPONENT POLYUREA PRIMER (0.5 -1.0 MILS DRY FILM THICKNESS, 150 FT2/GAL), ONE INTERMEDIATE COAT OF A DUAL COMPONENT POLYUREA (50-100 MILS DRY FILM THICKNESS, 50 FT2/GAL) AND ONE TOP COAT OF A 65% SOLIDS, TWO-PART POLYUREA (7.5-10 MILS DRY FILM THICKNESS, 125 FT2/GAL). ALL COATS CAN BE APPLIED BY BRUSH, SPRAY, OR ROLLER. SHERFLEX ELASTOMERIC POLYURETHANE SHALL BE APPLIED ACCORDING TO MANUFACTURER'S RECOMMENDATIONS. POLYUREA/POLYURETHANE COATINGS SHALL BE DURAMER 1030 AS MANUFACTURED BY SEWERKOTE, SHERFLEX ELASTOMERIC POLYURETHANE AS MANUFACTURED BY SHERWIN-WILLIAMS, OR APPROVED EQUAL.

TABLE 1

LOW PRESSURE AIR TESTING FOR GRAVITY SEWER MAINS

MINIMUM TIME REQUIRED FOR A MAXIMUM 1.0 PSIG PRESSURE DROP FOR SIZE AND LENGTH OF PIPE INDICATED

1 Pipe Dia. (in.)	2 Minimum Time (min:sec)	3 Length for Minimum Time (ft)	4 Time for Longer Length (sec)	5 Specification Time for Length (L) Shown (min:sec)							
				100 ft	150 ft	200 ft	250 ft	300 ft	350 ft	400 ft	450 ft
4	3:46	597	380 L	3:46	3:46	3:46	3:46	3:46	3:46	3:46	3:46
6	5:40	398	854 L	5:40	5:40	5:40	5:40	5:40	5:40	5:42	6:24
8	7:34	298	1,520 L	7:34	7:34	7:34	7:36	7:36	7:36	8:52	10:08
10	9:26	239	2,374 L	9:26	9:26	9:26	9:53	9:53	11:52	13:51	15:49
12	11:20	199	3,418 L	11:20	11:20	11:24	14:15	14:15	19:56	22:47	25:38
15	14:10	159	5,324 L	14:10	14:10	17:48	22:15	22:15	28:42	31:09	35:36
18	17:00	133	7,692 L	17:00	19:13	25:38	32:03	32:03	38:27	44:52	51:16
21	19:50	114	10,470 L	19:50	26:10	34:54	43:37	43:37	52:21	61:00	69:48
24	22:40	99	13,674 L	22:47	34:11	45:34	56:58	56:58	68:22	79:46	91:10
27	25:30	88	17,306 L	28:51	43:16	57:41	72:07	72:07	86:32	100:57	115:22
30	28:20	80	21,366 L	35:37	53:25	71:13	89:02	89:02	106:50	124:38	142:26
33	31:10	72	25,852 L	43:05	64:38	86:10	107:43	107:43	129:16	150:43	172:21
36	34:00	66	30,768 L	51:17	76:55	102:34	128:12	128:12	153:50	179:29	205:07

This Table is from UNI-B-6-90. The table is based on a Q (allowable air loss rate in test section) = 0.0015 cubic feet / minute / square feet. To shorten required test time a maximum pressure drop of 0.5 psig may be used and time requirements reduced by half.

1 LOW PRESSURE AIR TESTING TABLE

MWC	02/24/22	3RD SUBMITTAL TO TRC
JV	12/29/22	2ND SUBMITTAL TO TRC
GDF	10/28/22	90% DESIGN 1ST SUBMITTAL TO TRC
BY	DATE	REVISION

PRELIMINARY DESIGN NOT RELEASED FOR CONSTRUCTION



HIGHFILL
INFRASTRUCTURE
ENGINEERING, P.C.

2703 Jones Franklin Rd, Suite 201
Cary, NC 27518
Tel 919-481-4342
Fax 919-882-9762
www.hiepc.com
Firm License No. C-2586

*Engineering is our profession.
Service is our passion.*

WALLBROOK OFFSITE UTILITY IMPROVEMENTS
WALLBROOK LANDCO
ROLESVILLE, NC

TECHNICAL SPECIFICATIONS

PROJECT NO.
CSE2201

C-0.2

CD 22-06

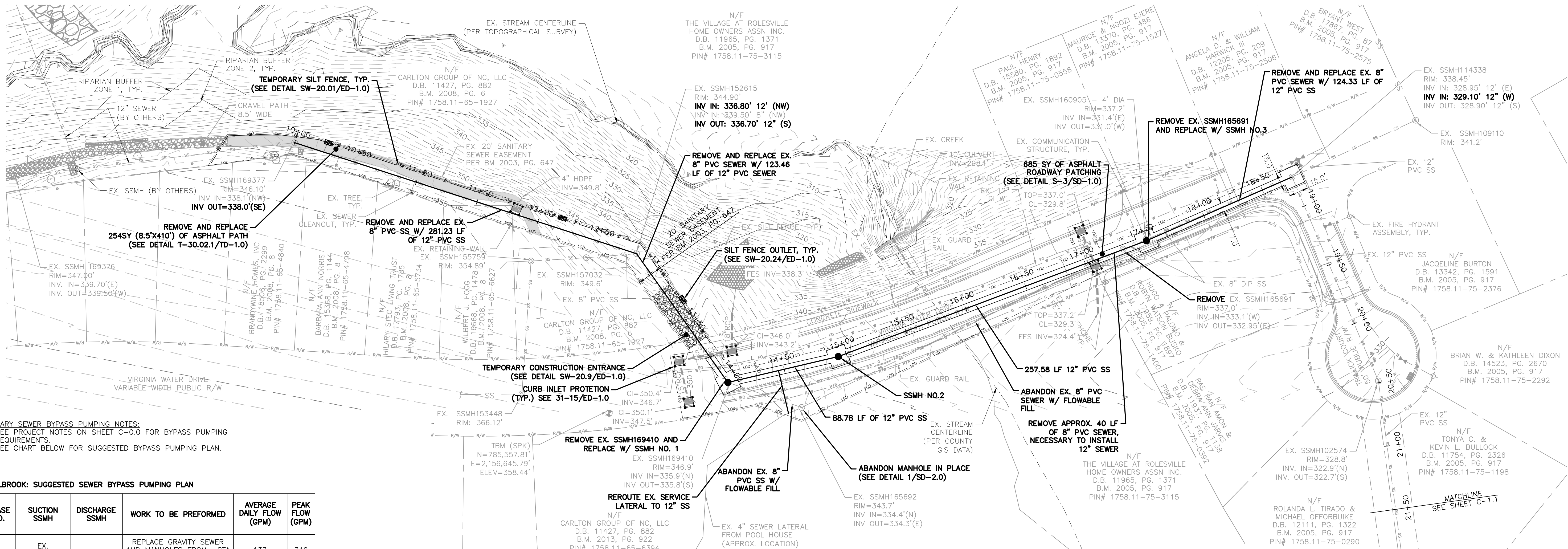

SANITARY SEWER BYPASS PUMPING NOTES:
 1. SEE PROJECT NOTES ON SHEET C-0.0 FOR BYPASS PUMPING REQUIREMENTS.
 2. SEE CHART BELOW FOR SUGGESTED BYPASS PUMPING PLAN.

WALLBROOK: SUGGESTED SEWER BYPASS PUMPING PLAN

PHASE NO.	SUCTION SSMH	DISCHARGE SSMH	WORK TO BE PREFORMED	AVERAGE DAILY FLOW (GPM)	PEAK FLOW (GPM)
1	EX. SSMH165692	EX. SSMH102574	REPLACE GRAVITY SEWER AND MANHOLES FROM ~STA 14+25 TO STA 18+75	133	340
	EX. SSMH109110		REPLACE EX. SSMH114338	350	900
2	EX. SSMH169376	SSMH 2	REPLACE GRAVITY SEWER AND MANHOLES FROM ~STA 10+00 TO STA 14+25	133	340

1 PLAN - STA. 10+00 TO 18+75
 SCALE: 1" = 40'

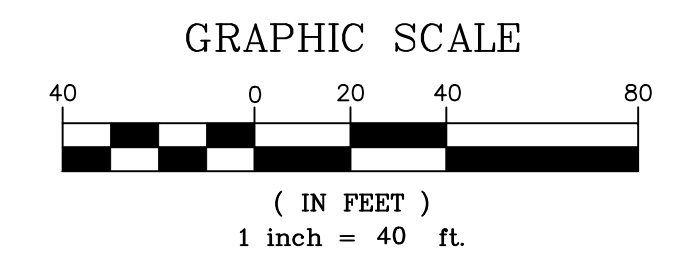

- BENCHMARK:**
 1. TBM (SPK) LOCATED APPROXIMATELY 95 FT WEST OF MANHOLE 2
- NOTES:**
 1. SEE DETAIL S-5/SD-1.0 FOR TRENCH AND BACKFILL.
 2. ALL CONSTRUCTION SHALL ADHERE TO CITY OF RALEIGH STANDARDS AND SPECIFICATIONS.
 3. CONTRACTOR SHALL CORE DRILL EXISTING MANHOLE TO ACCOMMODATE NEW LINE SIZE.
 4. MODIFY EXISTING MANHOLE TROUGH FOR NEW SEWER LINE.
 5. ALL EXISTING AND NEW MANHOLES TO BE EPOXY COATED, SEE MANHOLE EPOXY LINER NOTE.
 6. STEEL ENCASUREMENT (MIN WALL THICKNESS 0.50") AND 12" SDR35 PVC SEWER, CENTER THE PVC SEWER PIPE ON THE STEEL ENCASUREMENT PIPE SO THAT THERE ARE NO JOINTS WITHIN THE STEEL ENCASUREMENT.

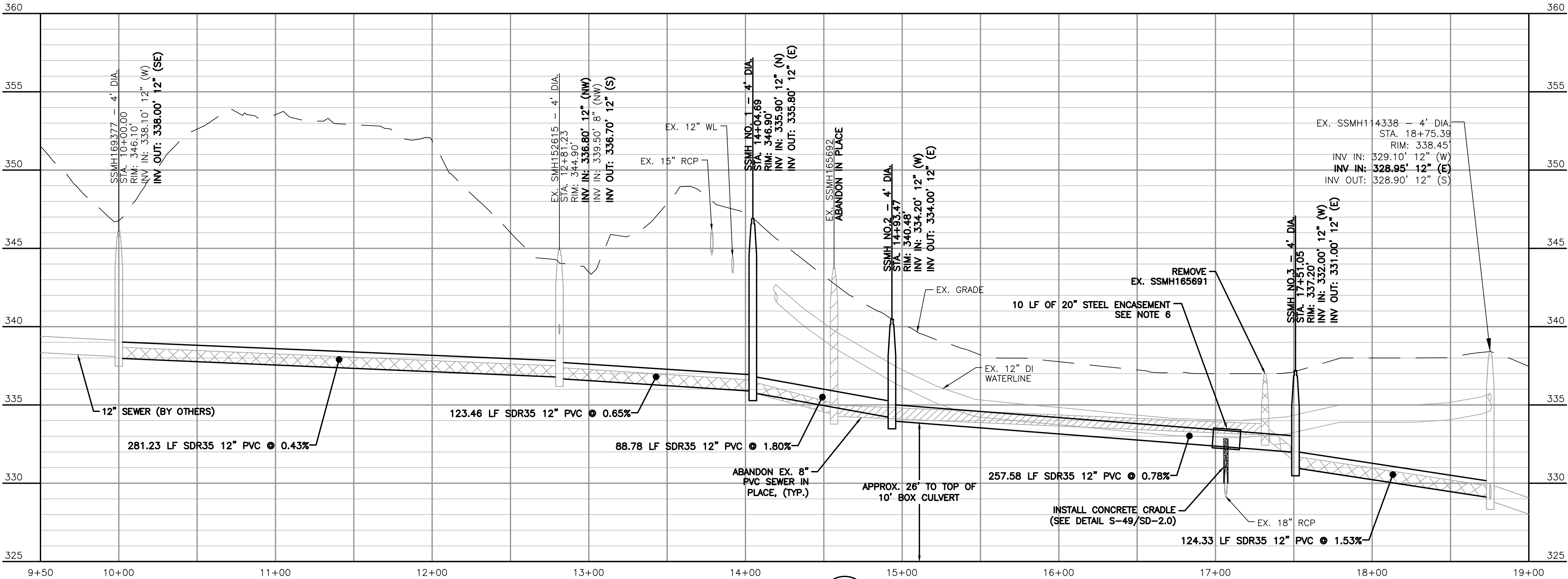

2 PROFILE - STA. 10+00 TO 18+75
 SCALE: 1" = 40'
 VERTICAL SCALE: 1" = 4'

Public Sewer Collection / Extension System

The City of Raleigh consents to the connection and extension of the City's public sewer system as shown on this plan. The material and Construction methods used for this project shall conform to the standards and specifications of the City's Public Utilities Handbook.

City of Raleigh
 Public Utilities Department Permit # S-xxxx
 Authorization to Construct See digital signature

NOTE: ALL CONSTRUCTION SHALL ADHERE TO CITY OF RALEIGH STANDARDS AND SPECIFICATIONS
 CITY OF RALEIGH - PLANS AUTHORIZED FOR CONSTRUCTION

Plans for the proposed use have been reviewed for general compliance with applicable codes. This limited review, and authorization for construction is not to be considered to represent total compliance with all legal requirements for development and construction. The property owner, design consultants, and contractors are each responsible for compliance with all applicable City, State and Federal laws. This specific authorization below is not a permit, nor shall it be construed to permit any violation of City, State or Federal Law. All construction must be in accordance with all Local, State, and Federal Rules and Regulations. This approval of this electronic document is only valid if the document has not been modified and the digital signature below is valid.

City of Raleigh Development Approval

BY	REVISION	DATE
GF	90% DESIGN 1ST SUBMITTAL TO TRC	10/28/22
JV	2ND SUBMITTAL TO TRC	12/29/22
MWC	3RD SUBMITTAL TO TRC	02/24/23

PRELIMINARY DESIGN NOT RELEASED FOR CONSTRUCTION

2703 Jones Franklin Rd, Suite 201
 Cary, NC 27518
 Tel 919-481-4342
 Fax 919-882-9762
 www.hiepc.com
 Firm License No. C-2586

Engineering is our profession.
 Service is our passion.

WALLBROOK OFFSITE UTILITY IMPROVEMENTS
 WALLBROOK LANDCO
 ROLESVILLE, NC
 VIRGINIA WATER DRIVE STA 10+00 TO
 STA 19+00

PROJECT NO.
CSE2201
 C-1.0

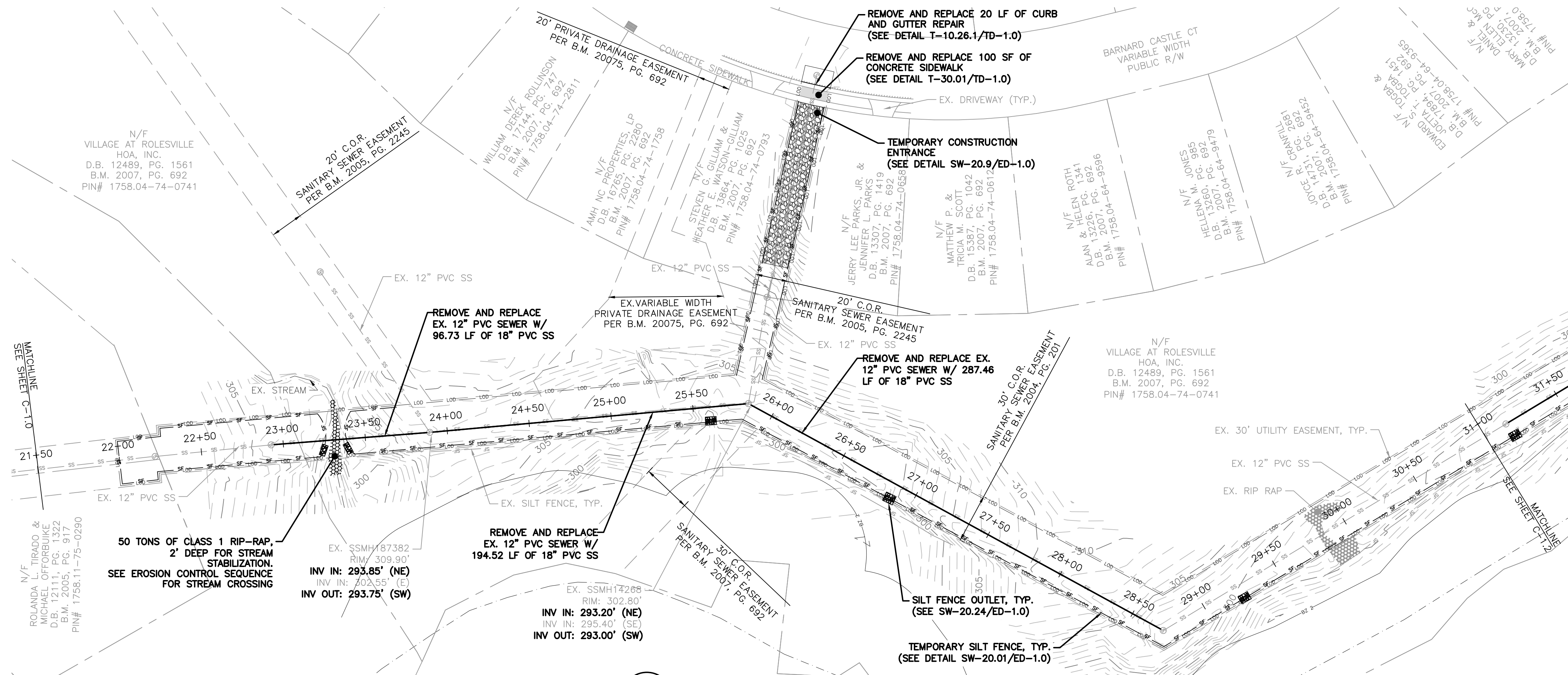

1 PLAN - STA. 22+50 TO 31+00
 SCALE: 1" = 40'
 GRAPHIC SCALE
 (IN FEET)
 1 inch = 40 ft.

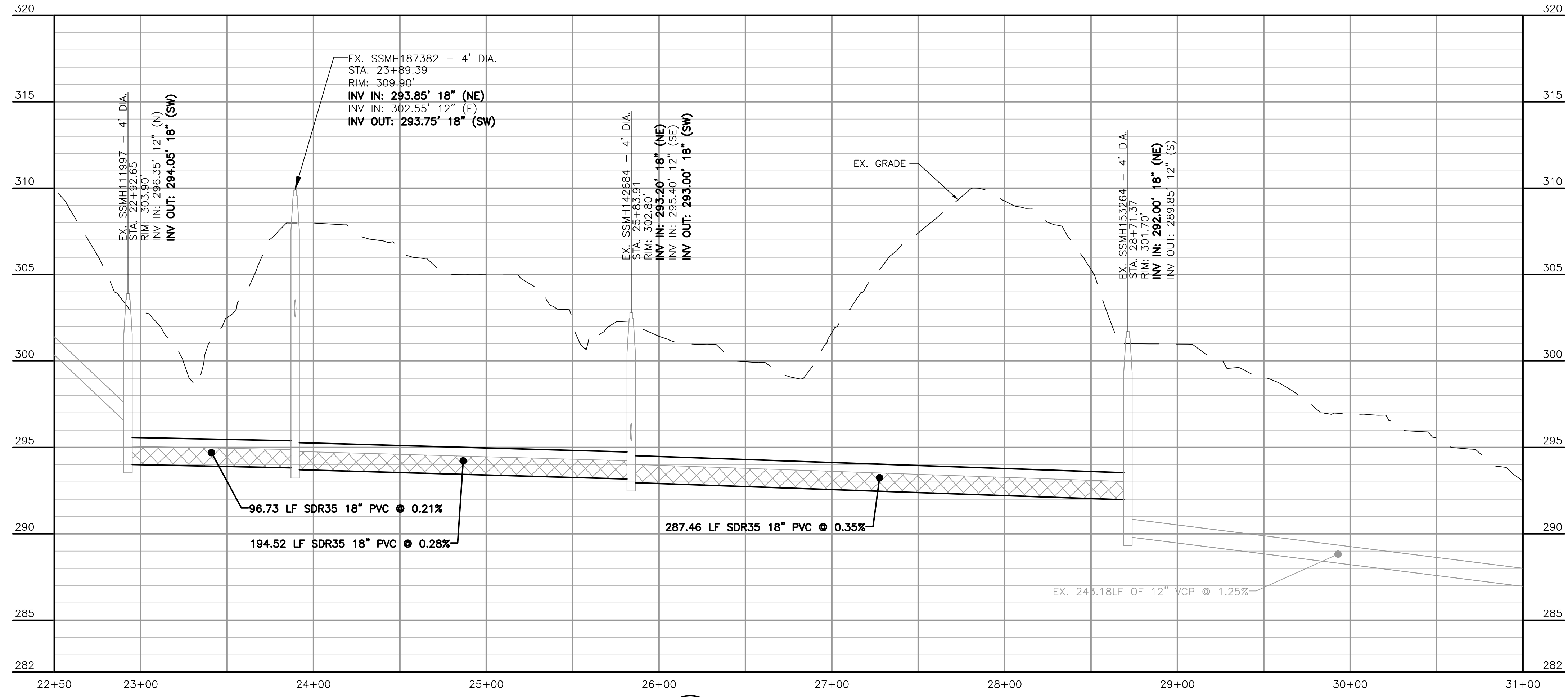

1 PROFILE - STA. 22+50 TO 31+00
 SCALE: 1" = 40'
 VERTICAL SCALE: 1" = 4'

- NOTES:**
- SEE DETAIL S-5/SD-1.0 FOR TRENCH AND BACKFILL.
 - ALL CONSTRUCTION SHALL ADHERE TO CITY OF RALEIGH STANDARDS AND SPECIFICATIONS.
 - CONTRACTOR SHALL CORE DRILL EXISTING MANHOLE TO ACCOMMODATE NEW LINE SIZE.
 - MODIFY EXISTING MANHOLE TROUGH FOR NEW SEWER LINE.
 - ALL EXISTING AND NEW MANHOLES TO BE EPOXY COATED, SEE MANHOLE EPOXY LINER NOTE.

- EROSION CONTROL SEQUENCE FOR STREAM CROSSING:**
- INSTALL SILT FENCE (SEE DETAIL SW-20.01/ED-1.0) AND SILT FENCE OUTLETS (SEE DETAIL SW-20.24/ED-1.0) AS INDICATED ALONG TOP OF BANK WHILE CLEARING AND GRUBBING.
 - INSTALL RIP-RAP SUCH THAT TOP OF RIP-RAP MATCHES PRE-CONSTRUCTION DITCH BED ELEVATION AND BANK ELEVATION CONTOURS.
 - UTILIZE DAMS AND PUMPING AS NECESSARY TO PREVENT DOWNSTREAM SEDIMENT TRANSPORTATION.
 - UPON FINAL COMPLETION OF CONSTRUCTION, CONTRACTOR SHALL INSTALL PERMANENT STREAM STABILIZATION (SEE 1/ED-3.0) AND REMOVE TEMPORARY EROSION CONTROL MEASURES.

**Public
Sewer Collection / Extension System**

The City of Raleigh consents to the connection and extension of the City's public sewer system as shown on this plan. The material and construction methods used for this project shall conform to the standards and specifications of the City's Public Utilities Handbook.

City of Raleigh
Public Utilities Department Permit # **S-xxxx**

Authorization to Construct See digital signature

NOTE: ALL CONSTRUCTION SHALL ADHERE TO CITY OF RALEIGH STANDARDS AND SPECIFICATIONS

CITY OF RALEIGH - PLANS AUTHORIZED FOR CONSTRUCTION

Plans for the proposed use have been reviewed for general compliance with applicable codes. This limited review, and authorization for construction is not to be considered to represent total compliance with all legal requirements for development and construction. The property owner, design consultants, and contractors are each responsible for compliance with all applicable City, State and Federal laws. This specific authorization below is not a permit, nor shall it be construed to permit any violation of City, State or Federal Law. All construction must be in accordance with all Local, State, and Federal Rules and Regulations. This approval of this electronic document is only valid if the document has not been modified and the digital signature below is valid.

City of Raleigh Development Approval _____

DATE	REVISION	BY
02/24/22	3RD SUBMITTAL TO TRC	MWC
02/24/22	3RD SUBMITTAL TO TRC	MWC
12/29/22	2ND SUBMITTAL TO TRC	JV

NORTH CAROLINA
PROFESSIONAL ENGINEER
SEAL 038689
BRIAN J.P. OSCINIELLO

SEAL NOT VALID UNLESS SIGNED AND DATED

HIGHFILL
INFRASTRUCTURE
ENGINEERING, P.C.

2703 Jones Franklin Rd, Suite 201
 Cary, NC 27518
 Tel 919-481-4342
 Fax 919-882-9762
 www.hiepc.com
 Firm License No. C-2586

Engineering is our profession.
 Service is our passion.

CD 22-06

WALLBROOK OFFSITE UTILITY IMPROVEMENTS
 WALLBROOK LANDCO
 ROLESVILLE, NC

SOUTH OF TRILICK CT STA 22+50 TO
 31+00

PROJECT NO.
CSE2201

C-1.1

PRELIMINARY DESIGN NOT RELEASED FOR CONSTRUCTION

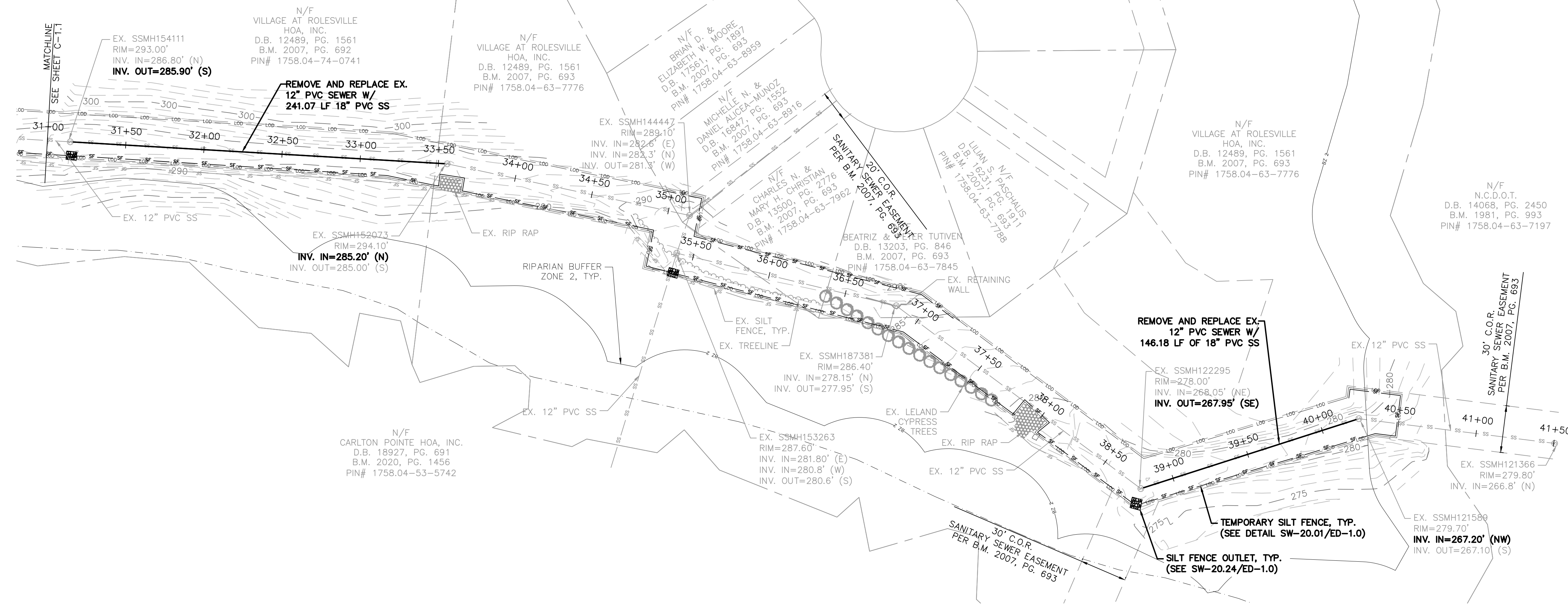

1 PLAN - STA. 31+00 TO 40+50
SCALE: 1" = 40'

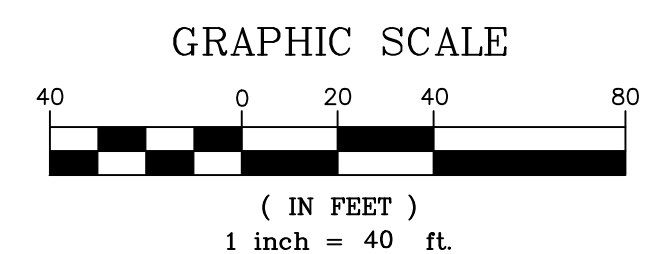

- NOTES:
1. SEE DETAIL S-5/SD-1.0 FOR TRENCH AND BACKFILL.
 2. ALL CONSTRUCTION SHALL ADHERE TO CITY OF RALEIGH STANDARDS AND SPECIFICATIONS.
 3. CONTRACTOR SHALL CORE DRILL EXISTING MANHOLE TO ACCOMMODATE NEW LINE SIZE.
 4. MODIFY EXISTING MANHOLE TROUGH FOR NEW SEWER LINE.
 5. ALL MANHOLES TO BE EPOXY COATED, SEE MANHOLE EPOXY LINER NOTE.

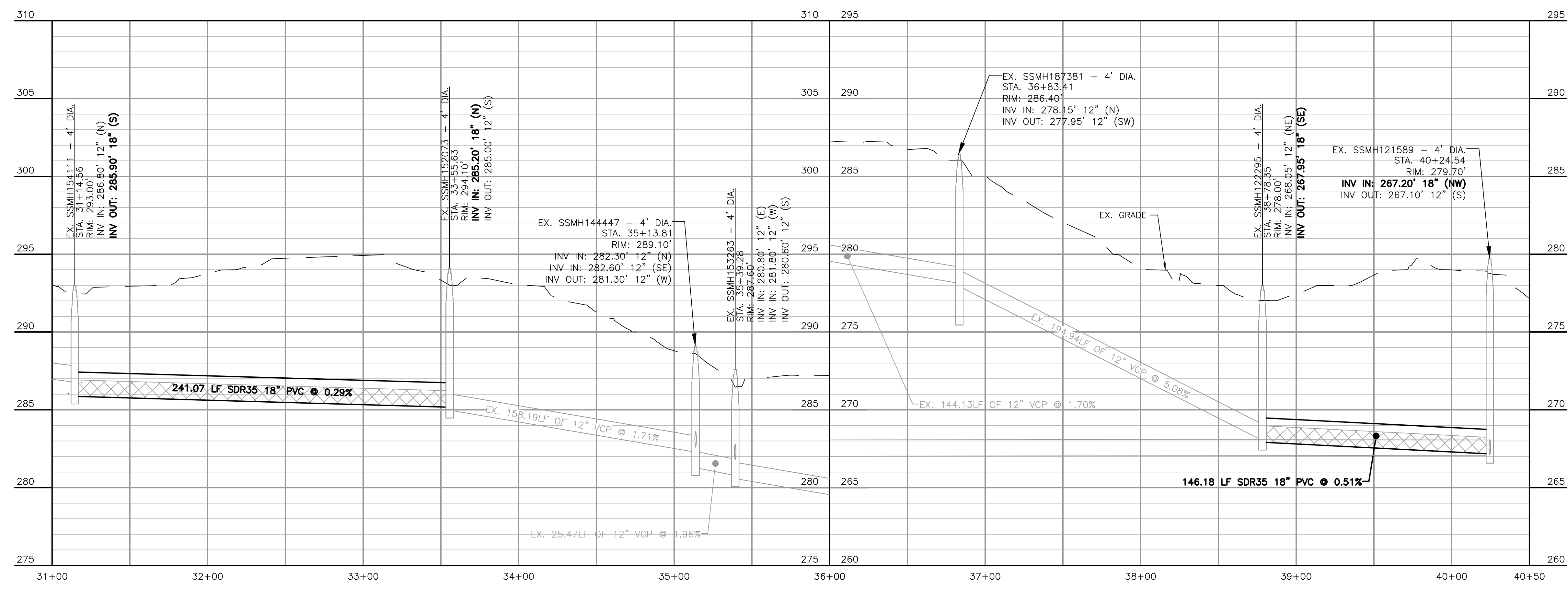

1 PROFILE - STA. 31+00 TO 40+50
SCALE: 1" = 40'
VERTICAL SCALE: 1" = 4'

Public Sewer Collection / Extension System

The City of Raleigh consents to the connection and extension of the City's public sewer system as shown on this plan. The material and Construction methods used for this project shall conform to the standards and specifications of the City's Public Utilities Handbook.

City of Raleigh
Public Utilities Department Permit # S-xxx
Authorization to Construct See digital signature

NOTE: ALL CONSTRUCTION SHALL ADHERE TO CITY OF RALEIGH STANDARDS AND SPECIFICATIONS

CITY OF RALEIGH - PLANS AUTHORIZED FOR CONSTRUCTION

Plans for the proposed use have been reviewed for general compliance with applicable codes. This limited review, and authorization for construction is not to be considered to represent total compliance with all legal requirements for development and construction. The property owner, design consultants, and contractors are each responsible for compliance with all applicable City, State and Federal laws. This specific authorization below is not a permit, nor shall it be construed to permit any violation of City, State or Federal Law. All construction must be in accordance with all Local, State, and Federal Rules and Regulations. This approval of this electronic document is only valid if the document has not been modified and the digital signature below is valid.

DATE	REVISION	BY
02/24/22	3RD SUBMITTAL TO TRC	MWC
02/24/22	3RD SUBMITTAL TO TRC	MWC
12/29/22	2ND SUBMITTAL TO TRC	JV

PRELIMINARY DESIGN NOT RELEASED FOR CONSTRUCTION

SEAL NOT VALID UNLESS SIGNED AND DATED

North Carolina Professional Engineer
SEAL 038689
ENGINEER
BRIAN J.P. OSCIFIELD

Highfill Infrastructure Engineering, P.C.
2703 Jones Franklin Rd, Suite 201
Cary, NC 27518
Tel 919-481-4342
Fax 919-882-9762
www.hiepc.com
Firm License No. C-2586

Engineering is our profession.
Service is our passion.

CD 22-06

WALLBROOK OFFSITE UTILITY IMPROVEMENTS
WALLBROOK LANDCO
ROLESVILLE, NC

SOUTH OF TRILICK CT STA 31+00 TO 40+50

PROJECT NO.
CSE2201

C-1.2

City of Raleigh Development Approval

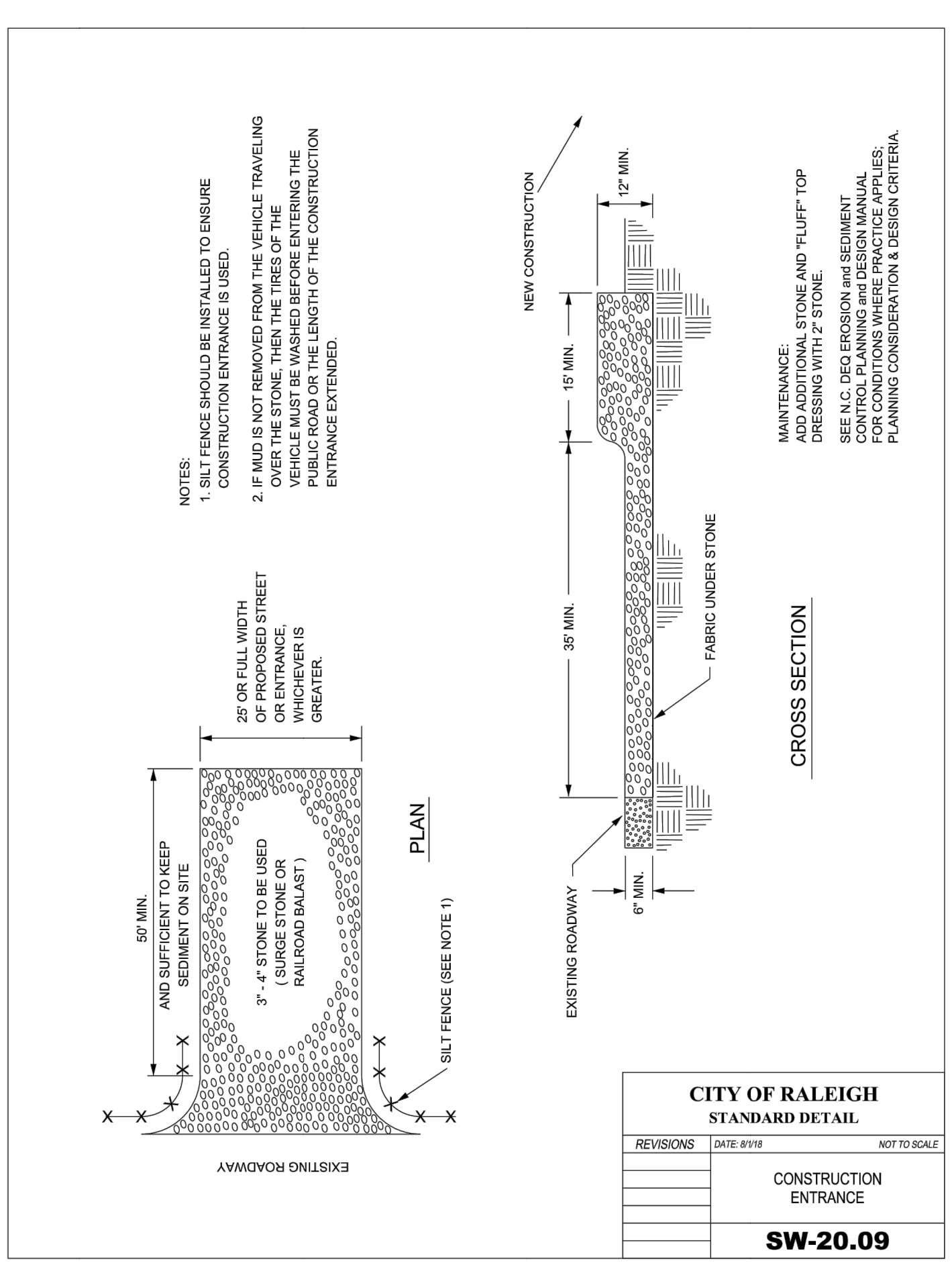
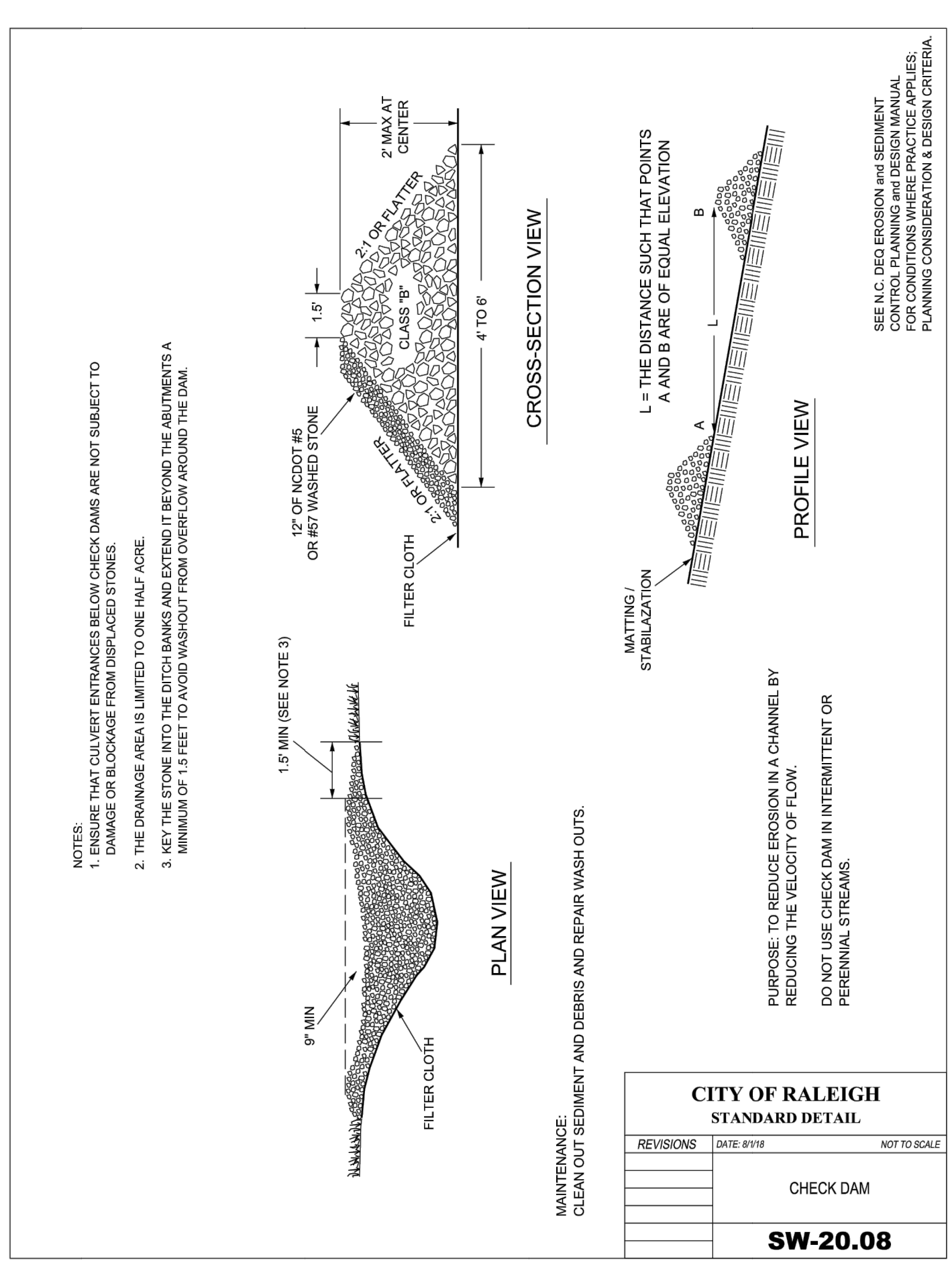
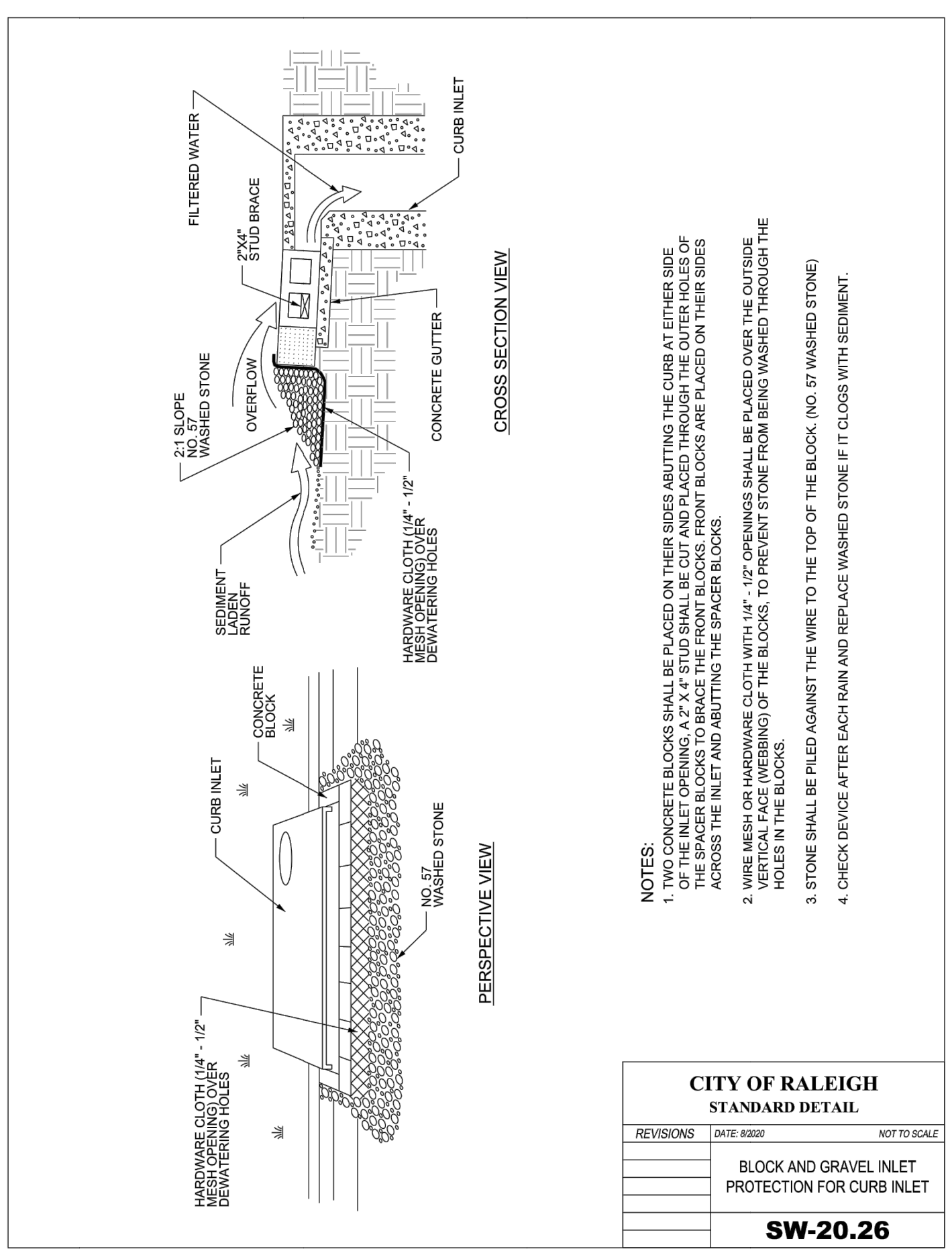
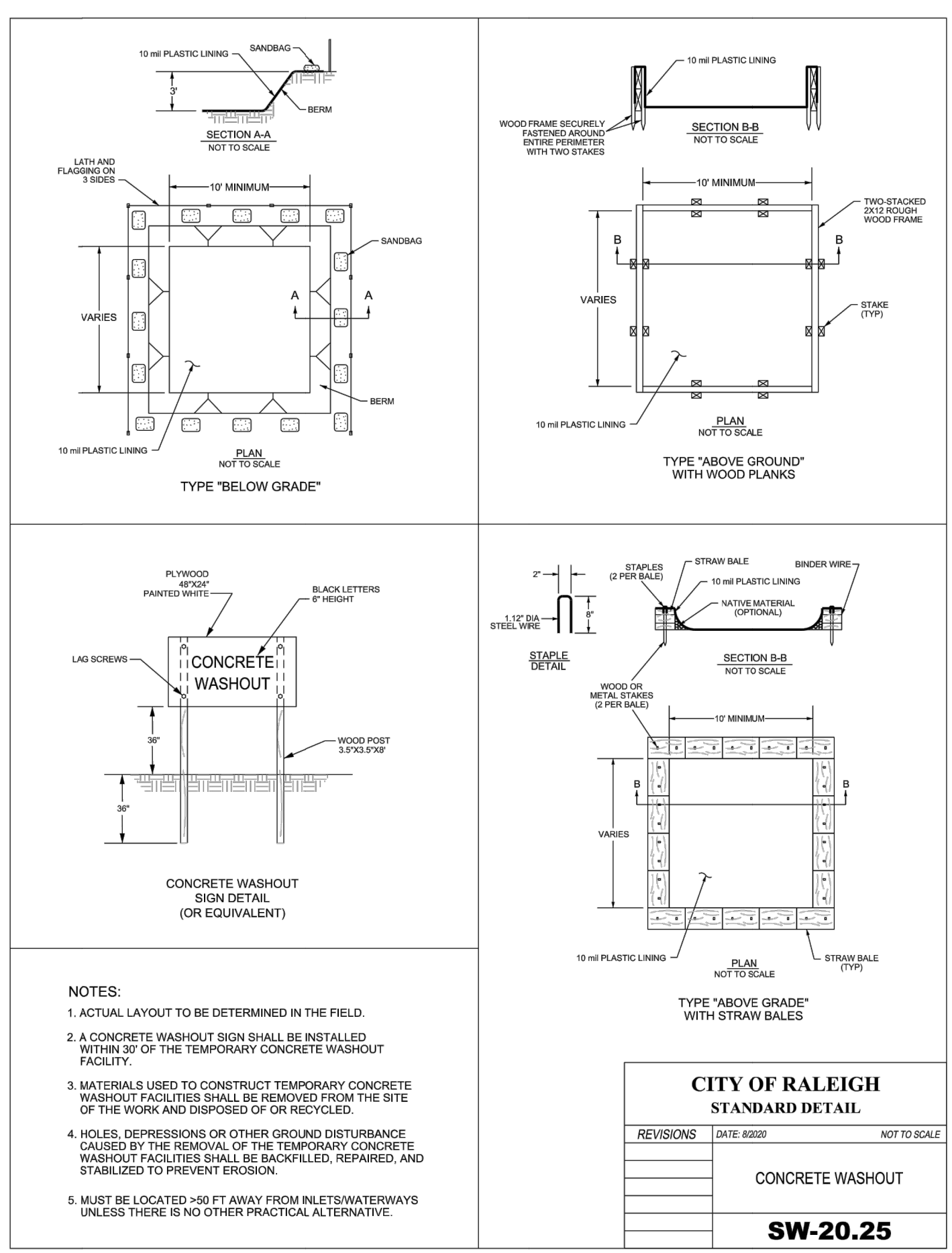
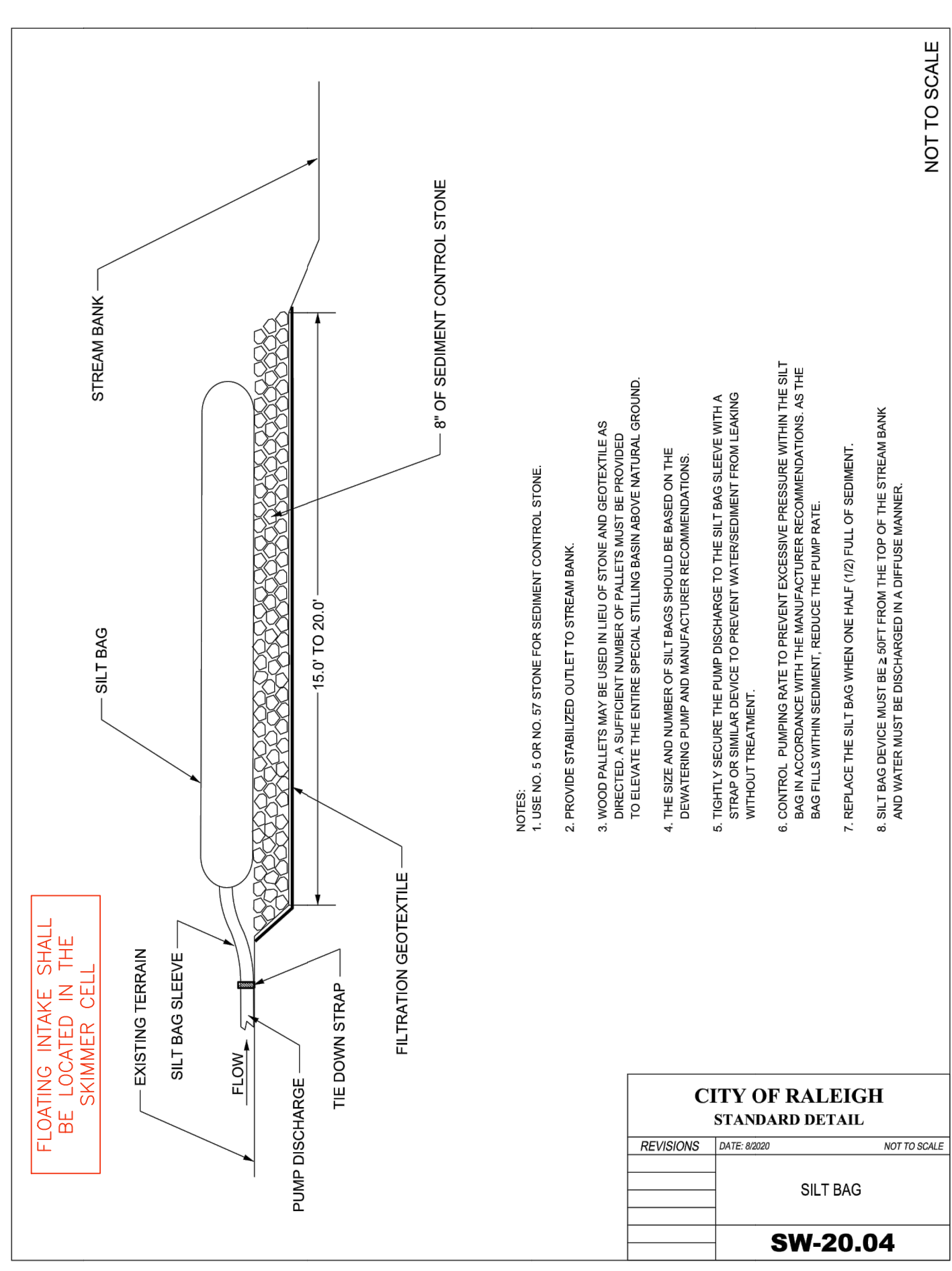
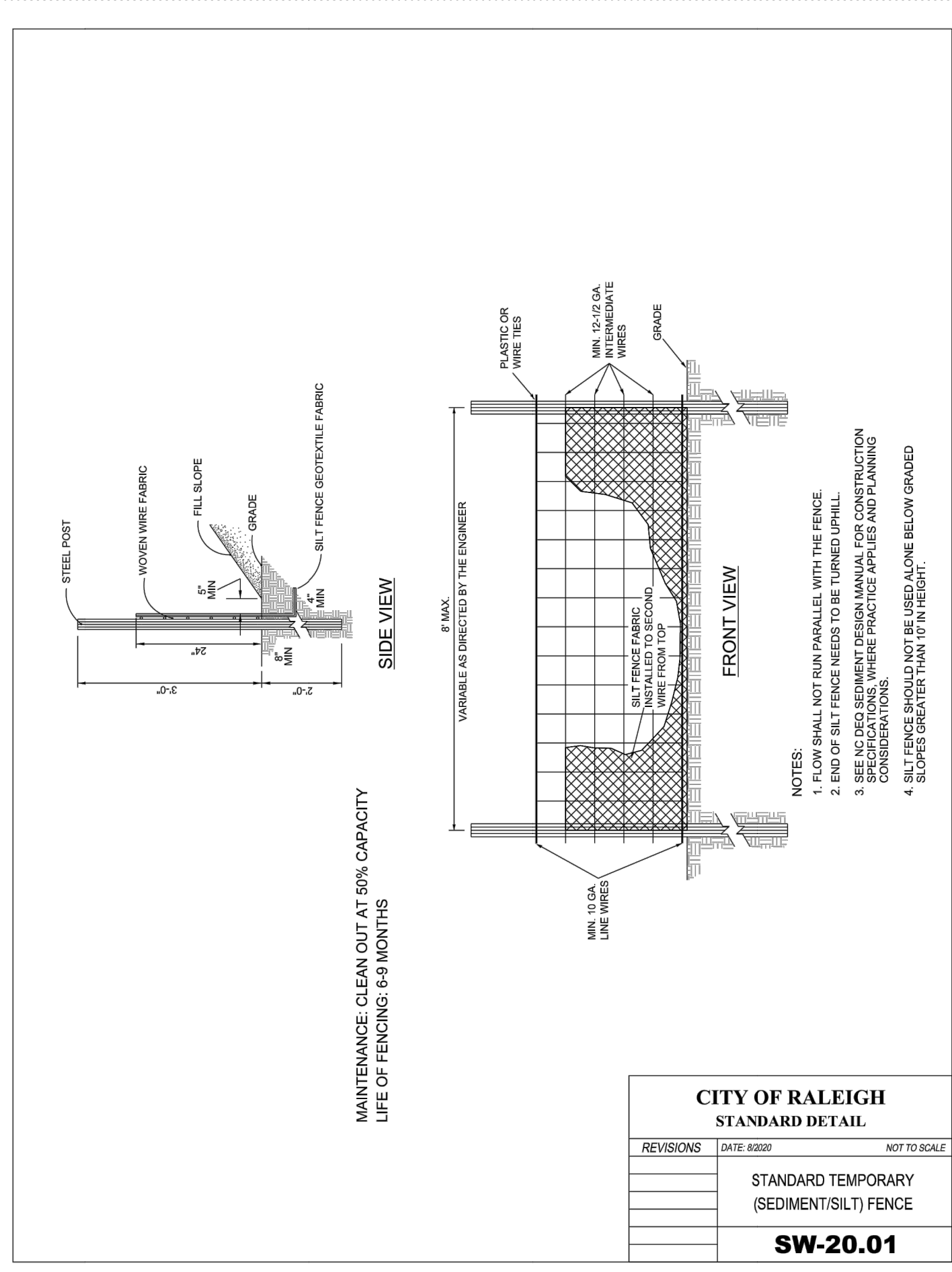
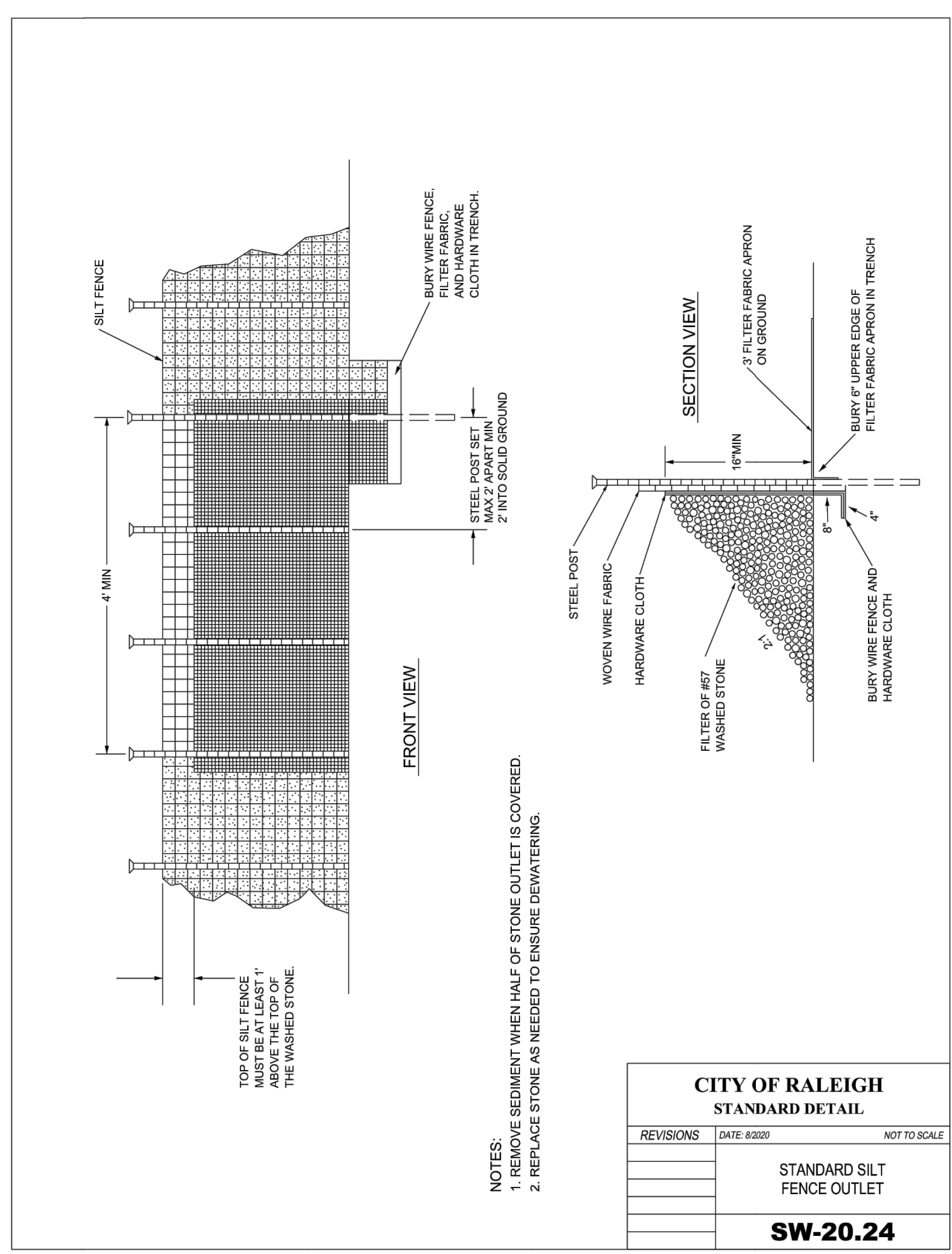
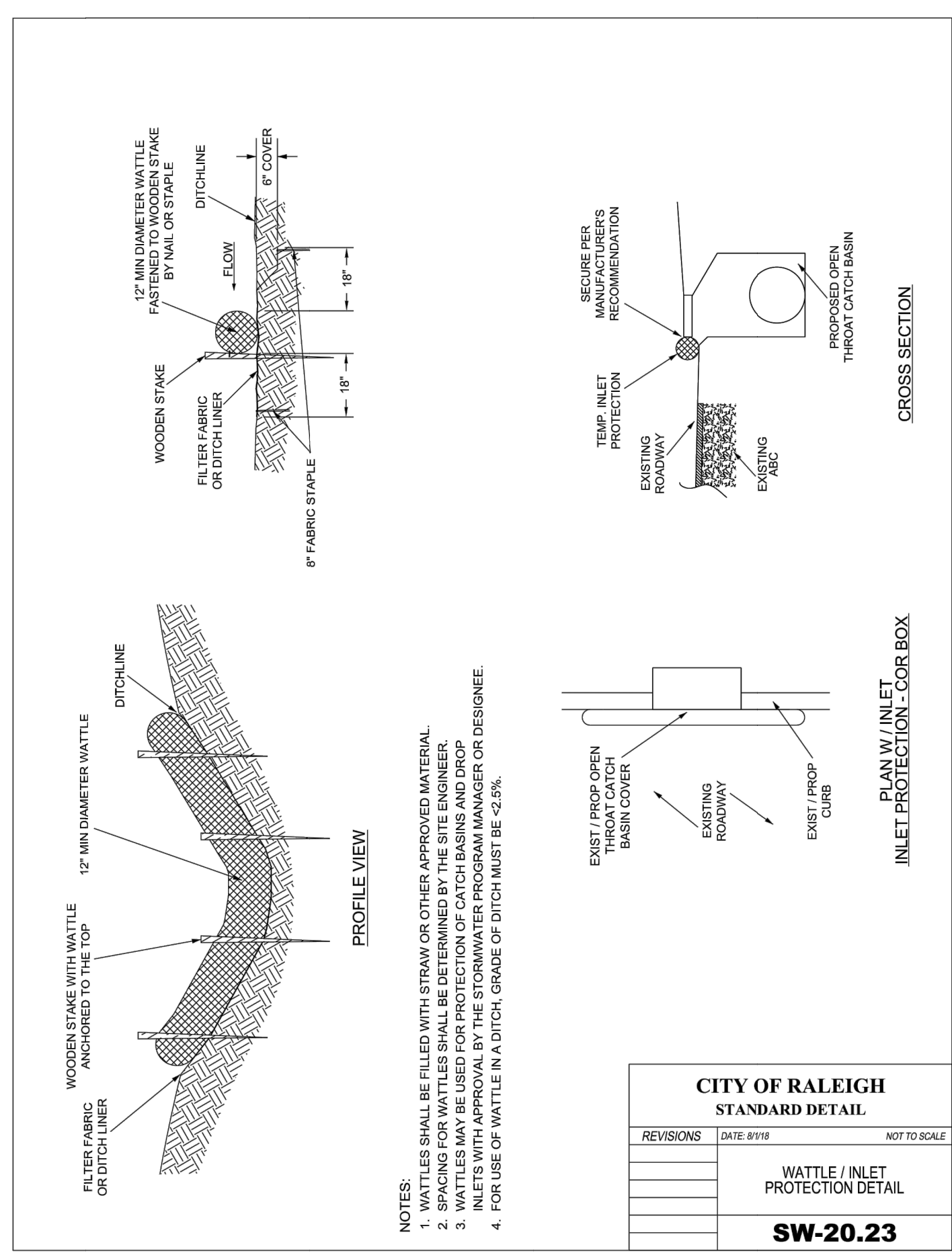

NOTE: ALL CONSTRUCTION SHALL ADHERE TO CITY OF RALEIGH STANDARDS AND SPECIFICATIONS CITY OF RALEIGH - PLANS AUTHORIZED FOR CONSTRUCTION

Plans for the proposed use have been reviewed for general compliance with applicable codes. This limited review, and authorization for construction is not to be considered to represent total compliance with all legal requirements for development and construction. The property owner, design consultants, and contractors are each responsible for compliance with all applicable City, State and Federal laws. This specific authorization below is not a permit, nor shall it be construed to permit any violation of City, State or Federal Law. All construction must be in accordance with all Local, State, and Federal Rules and Regulations. This approval of this electronic document is only valid if the document has not been modified and the digital signature below is valid.

City of Raleigh Development Approval

CD 22-06

WALLBROOK OFFSITE UTILITY IMPROVEMENTS

WALLBROOK LANDCO
ROLESVILLE, NC

EROSION CONTROL DETAILS

PROJECT NO.
CSE2201

ED-1.0

City of Raleigh Development Approval

Engineering is our profession.
Service is our passion.

2703 Jones Franklin Rd, Suite 201
Cary, NC 27518
Tel 919-481-4342
Fax 919-882-9762
www.hiepc.com
Firm License No. C-2586

HIGHFILL
INFRASTRUCTURE
ENGINEERING, P.C.

SEAL 038689
ENGINEER
BRIAN J. P. OSCARIELLO

REVISIONS

NO.	DATE	DESCRIPTION
1	02/24/22	MWC
2	12/29/22	JV
3	10/28/22	GDF

DATE

REVISION

BY

PRELIMINARY DESIGN NOT RELEASED FOR CONSTRUCTION

GROUND STABILIZATION AND MATERIALS HANDLING PRACTICES FOR COMPLIANCE WITH THE NCG01 CONSTRUCTION GENERAL PERMIT
 Implementing the details and specifications on this plan sheet will result in the construction activity being considered compliant with the Ground Stabilization and Materials Handling sections of the NCG01 Construction General Permit (Sections E and F, respectively). The permittee shall comply with the Erosion and Sediment Control plan approved by the delegated authority having jurisdiction. All details and specifications shown on this sheet may not apply depending on site conditions and the delegated authority having jurisdiction.

SECTION E: GROUND STABILIZATION

Site Area Description	Stabilize within this many calendar days after ceasing land disturbance	Timeframe variations
(a) Perimeter dikes, swales, ditches, and perimeter slopes	7	None
(b) High Quality Water (HQW) Zones	7	None
(c) Slopes steeper than 3:1	7	If slopes are 10' or less in length and are not steeper than 2:1, 14 days are allowed.
(d) Slopes 3:1 to 4:1	14	-7 days for slopes greater than 50' in length and with slopes steeper than 4:1 -7 days for perimeter dikes, swales, ditches, perimeter slopes and HQW Zones -10 days for Falls Lake Watershed
(e) Areas with slopes flatter than 4:1	14	-7 days for perimeter dikes, swales, ditches, perimeter slopes and HQW Zones -10 days for Falls Lake Watershed unless there is zero slope

Note: After the permanent cessation of construction activities, any areas with temporary ground stabilization shall be converted to permanent ground stabilization as soon as practicable but in no case longer than 90 calendar days after the last land disturbing activity. Temporary ground stabilization shall be maintained in a manner to render the surface stable against accelerated erosion until permanent ground stabilization is achieved.

GROUND STABILIZATION SPECIFICATION

Stabilize the ground sufficiently so that rain will not dislodge the soil. Use one of the techniques in the table below:

Temporary Stabilization	Permanent Stabilization
<ul style="list-style-type: none"> Temporary grass seed covered with straw or other mulches and tackifiers Hydroseeding Rollered erosion control products with or without temporary grass seed Appropriately applied straw or other mulch Plastic sheeting 	<ul style="list-style-type: none"> Permanent grass seed covered with straw or other mulches and tackifiers Geotextile fabrics such as permanent soil reinforcement matting Hydroseeding Shrubs or other permanent plantings covered with mulch Uniform and evenly distributed ground cover sufficient to retain erosion Structural methods such as concrete, asphalt or retaining walls Rollered erosion control products with grass seed

POLYACRYLAMIDES (PAMS) AND FLOCCULANTS

- Select flocculants that are appropriate for the soils being exposed during construction, selecting from the *NC DWR List of Approved PAMS/Flocculants*.
- Apply flocculants at or before the inlets to Erosion and Sediment Control Measures.
- Apply flocculants at the concentrations specified in the *NC DWR List of Approved PAMS/Flocculants* and in accordance with the manufacturer's instructions.
- Provide ponding area for containment of treated Stormwater before discharging offsite.
- Store flocculants in leak-proof containers that are kept under storm-resistant cover or surrounded by secondary containment structures.

- EQUIPMENT AND VEHICLE MAINTENANCE**
- Maintain vehicles and equipment to prevent discharge of fluids.
 - Provide drip pans under any stored equipment.
 - Identify leaks and repair as soon as feasible, or remove leaking equipment from the project.
 - Collect all spent fluids, store in separate containers and properly dispose as hazardous waste (recycle when possible).
 - Remove leaking vehicles and construction equipment from service until the problem has been corrected.
 - Bring used fuels, lubricants, coolants, hydraulic fluids and other petroleum products to a recycling or disposal center that handles these materials.

- LITTER, BUILDING MATERIAL AND LAND CLEARING WASTE**
- Never bury or burn waste. Place litter and debris in approved waste containers.
 - Provide a sufficient number and size of waste containers (e.g. dumpster, trash receptacle) on site to contain construction and domestic wastes.
 - Locate waste containers at least 50 feet away from storm drain inlets and surface waters unless no other alternatives are reasonably available.
 - Locate waste containers on areas that do not receive substantial amounts of runoff from upland areas and does not drain directly to a storm drain, stream or wetland.
 - Cover waste containers at the end of each workday and before storm events or provide secondary containment. Repair or replace damaged waste containers.
 - Anchor all lightweight items in waste containers during times of high winds.
 - Empty waste containers as needed to prevent overflow. Clean up immediately if containers overflow.
 - Dispose waste off-site at an approved disposal facility.
 - On business days, clean up and dispose of waste in designated waste containers.

- PAINT AND OTHER LIQUID WASTE**
- Do not dump paint and other liquid waste into storm drains, streams or wetlands.
 - Locate paint washouts at least 50 feet away from storm drain inlets and surface waters unless no other alternatives are reasonably available.
 - Contain liquid wastes in a controlled area.
 - Containment must be labeled, sized and placed appropriately for the needs of site.
 - Prevent the discharge of soaps, solvents, detergents and other liquid wastes from construction sites.

- PORTABLE TOILETS**
- Install portable toilets on level ground, at least 50 feet away from storm drains, streams or wetlands unless there is no alternative reasonably available. If 50 foot offset is not attainable, provide relocation of portable toilet behind silt fence or place on a gravel pad and surround with sand bags.
 - Provide stacking or anchoring of portable toilets during periods of high winds or in high traffic areas.
 - Monitor portable toilets for leaking and properly dispose of any leaked material. Utilize a licensed sanitary waste hauler to remove leaking portable toilets and replace with properly operating unit.

- EARTHEN STOCKPILE MANAGEMENT**
- Show stockpile locations on plans. Locate earthen-material stockpile areas at least 50 feet away from storm drain inlets, sediment basins, perimeter sediment controls and surface waters unless it can be shown no other alternatives are reasonably available.
 - Protect stockpile with silt fence installed along toe of slope with a minimum offset of five feet from the toe of stockpile.
 - Provide stable stone access point when feasible.
 - Stabilize stockpile within the timeframes provided on this sheet and in accordance with the approved plan and any additional requirements. Soil stabilization is defined as vegetative, physical or chemical coverage techniques that will restrain accelerated erosion on disturbed soils for temporary or permanent control needs.

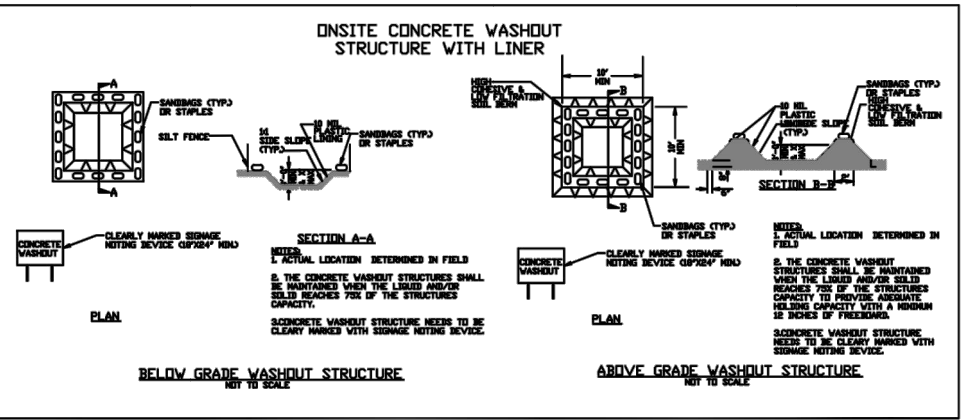

- CONCRETE WASHOUTS**
- Do not discharge concrete or cement slurry from the site.
 - Dispose of, or recycle settled, hardened concrete residue in accordance with local and state solid waste regulations and an approved facility.
 - Manage washout from mortar mixers in accordance with the above item and in addition place the mixer and associated materials on impervious barrier and within lot perimeter silt fence.
 - Install temporary concrete washouts per local requirements, where applicable. If an alternate method or product is to be used, contact your approval authority for review and approval. If local standard details are not available, use one of the two types of temporary concrete washouts provided on this detail.
 - Do not use concrete washouts for dewatering or storing defective curb or sidewalk sections. Stormwater accumulated within the washout may not be pumped into or discharged to the storm drain system or receiving surface waters. Liquid waste must be pumped out and removed from project.
 - Locate washouts at least 50 feet from storm drain inlets and surface waters unless it can be shown that no other alternatives are reasonably available. At a minimum, install protection of storm drain inlet(s) closest to the washout which could receive spills or overflow.
 - Locate washouts in an easily accessible area, on level ground and install a stone entrance pad in front of the washout. Additional controls may be required by the approving authority.
 - Install at least one sign directing concrete trucks to the washout within the project limits. Post signage on the washout itself to identify this location.
 - Remove leavings from the washout when at approximately 75% capacity to limit overflow events. Replace the tarp, sand bags or other temporary structural components when no longer functional. When utilizing alternative or proprietary products, follow manufacturer's instructions.
 - At the completion of the concrete work, remove remaining leavings and dispose of in an approved disposal facility. Fill pit, if applicable, and stabilize any disturbance caused by removal of washout.

- HERBICIDES, PESTICIDES AND RODENTICIDES**
- Store and apply herbicides, pesticides and rodenticides in accordance with label restrictions.
 - Store herbicides, pesticides and rodenticides in their original containers with the label, which lists directions for use, ingredients and first aid steps in case of accidental poisoning.
 - Do not store herbicides, pesticides and rodenticides in areas where flooding is possible or where they may spill or leak into wells, stormwater drains, ground water or surface water. If a spill occurs, clean area immediately.
 - Do not stockpile these materials onsite.

- HAZARDOUS AND TOXIC WASTE**
- Create designated hazardous waste collection areas on-site.
 - Place hazardous waste containers under cover or in secondary containment.
 - Do not store hazardous chemicals, drums or bagged materials directly on the ground.

PERMANENT SEEDING (MAX. SLOPE 3:1)

PLANTING PERIOD	SEED MIXTURE	RATE (LB/AC)
AUG. 15 - NOV. 1	TALL FESCUE	300
NOV. 1 - MAR. 1	TALL FESCUE & ABRUZZI RYE	300 25
MAR. 1 - APR. 15	TALL FESCUE	300
APR. 15 - JUNE 30	HULLED COMMON BERMUDAGRASS	25
JUL. 1 - AUG. 15**	TALL FESCUE & BROWNTOP MILLET & SORGHUM-SUDAN HYBRIDS	120 35 30
LIME		4,000
FERTILIZER	10-10-10	1,000
MULCH	STRAW	4,000

** DENOTES TEMPORARY SEEDING MIXTURE. RESEED ACCORDING TO OPTIMUM SEASON FOR PERMANENT SEEDING.

- SOIL PREPARATION:**
- SCARIFY SUBSOIL TO A DEPTH OF 3 INCHES.
 - SPREAD TOPSOIL TO A MINIMUM DEPTH OF 4 INCHES.
- SEED:**
- ACCOMPLISH SEEDING BY MEANS OF AN APPROVED POWER DRAWN SEED DRILL, COMBINATION CORRUGATED ROLLER SEEDER, APPROVED HAND OPERATED MECHANICAL SEEDER, OR OTHER APPROVED METHODS TO PROVIDE EVEN DISTRIBUTION OF SEED.
 - FRESH SEED GUARANTEED 95 PERCENT PURE WITH A MINIMUM GERMINATION RATE OF 85 PERCENT WITHIN ONE YEAR OF TESTS.
 - DETERMINE AND MATCH EXISTING GRASS TYPE IN RESIDENTIAL LAWNS.
 - PROVIDE THE ABOVE SEED MIXTURES, WITH LIME AND FERTILIZER, IN DISTURBED AREAS INCLUDING NODOT RIGHT-OF-WAYS.
- FERTILIZER:**
- MIXED, COMMERCIAL, FERTILIZER CONTAINING 10-10-10 PERCENTAGES OF AVAILABLE NITROGEN, PHOSPHORIC ACID, AND POTASH RESPECTIVELY, PLUS SUPERPHOSPHATE WITH 20 PERCENT P2O5 CONTENT.
 - FERTILIZER SHALL BE DRY, IN GRANULAR (PELLET) FORM, SHALL BE DELIVERED TO THE SITE IN THE MANUFACTURER'S ORIGINAL BAG OR CONTAINER WHICH SHALL BE PLAINLY MARKED AS TO FORMULA.

PERMANENT SEEDING (SLOPES FROM 3:1 TO 2:1)

PLANTING PERIOD	SEED MIXTURE	RATE (LB/AC)
MAR. 1 - JUNE 1	SERICA LESPEDeza & ADD TALL FESCUE	50 120
MAR. 1 - APR. 15	OR ADD WEEPING LOVEGRASS	10
MAR. 1 - JUN. 30	OR ADD HULLED COMMON BERMUDAGRASS	25
JUN. 1 - SEPT. 1**	TALL FESCUE & BROWNTOP MILLET & SORGHUM-SUDAN HYBRIDS	125 30 35
SEPT. 1 - MAR. 1	SERICA LESPEDeza (UNHULLED-UNSCARIFIED) & TALL FESCUE	70
NOV. 1 - MAR. 1	& ADD ABRUZZI RYE	120 25
LIME		4,000
FERTILIZER	10-10-10	1,000
MULCH	STRAW	4,000

** DENOTES TEMPORARY SEEDING MIXTURE. RESEED ACCORDING TO OPTIMUM SEASON FOR PERMANENT SEEDING.

- LIME:**
- GROUND DOLOMITIC AGRICULTURAL LIMESTONE, NOT LESS THAN 85 PERCENT TOTAL CARBONATES, GROUND SOT THAT 50 PERCENT PASSES 100 MESH SIEVE AND 90 PERCENT PASSES 30 MESH SIEVE. COARSER MATERIAL WILL BE ACCEPTABLE, PROVIDED THE SPECIFIED RATES OF APPLICATION ARE INCREASED PROPORTIONATELY ON THE BASIS OF QUANTITIES PASSING NO. 100 MESH SIEVE.
 - MULCHING AND MATTING.
 - SLOPES FROM 0 TO 20 PERCENT: NOT LESS THAN 85 LBS PER 1,000 SQ. FT. USE TACK TO PREVENT DISRUPTION OF MULCH.
 - SLOPES GREATER THAN 20 PERCENT MULCH WITH MATTING, PIN MATTING TO THE GROUND WITH WIRE STAPLES AT 5-FOOT INTERVALS, IMMEDIATELY AFTER SEEDING.
 - FOR TACK USE AN ASPHALT TIE-DOWN OF EMULSIFIED ASPHALT GRADE AE-3 OR CUT-BACK ASPHALT GRADE RC-2 OR OTHER APPROVED EQUAL. THE APPLICATION RATE SHALL BE 0.10 GAL/SY (11 GAL. PER 1,000 SQ. FT.). AN APPROVED JUTE MESH OR NET MAY BE USED IN LIEU OF TACKING STRAW MULCH.

NOTE: THE PROJECT CONTACT FOR MAINTENANCE OF EROSION CONTROL DEVICES IS MATT COTTON WITH THE CITY OF RALEIGH AT 919-996-3528.

1 TEMPORARY & PERMANENT SEEDING

PERMANENT RIPARIAN/WETLAND SEED MIXTURE ACCORDING TO PLANTING PERIOD FOR PIEDMONT

COMMON NAME	TYPE*	PERCENTAGE OF MIX	OPTIMAL PLANTING DATES
SWITCHGRASS	WARM SEASON	10-15%	
INDIANGRASS	WARM SEASON	10-30%	
DEERTONGUE	WARM SEASON	5-25%	
BIG BLUESTEM	WARM SEASON	10-30%	
LITTLE BLUESTEM	WARM SEASON	10-30%	
SWEET WOODREED	WARM SEASON	1-10%	DEC. 1 - APR. 1
RICE CUTGRASS	WARM SEASON	5-25%	
REDTOP PANICGRASS	WARM SEASON	10-20%	
BEAKED PANICGRASS	WARM SEASON	10-20%	
PURPLE TOP	WARM SEASON	5-10%	
EASTERN GAMMAGRASS	WARM SEASON	5-10%	
INDIAN WOODDATS	COLD SEASON	1-10%	
VIRGINIA WILD RYE	COLD SEASON	5-25%	
EASTERN BOTTLE-BRUSH GRASS	COLD SEASON	5-10%	FEB. 15 - APR. 1, AUG. 15 - OCT. 15
ROUGH BENTGRASS	COLD SEASON	10-20%	
WINTER BENTGRASS	COLD SEASON	2-5%	
SOFT RUSH	WETLAND	1-10%	
SHALLOW SEDGE	WETLAND	1-10%	DEC. 1 - MAY 1, SEP. 1 - NOV. 1
FOX SEDGE	WETLAND	1-10%	
LEATHERY RUSH	WETLAND	2-5%	
*PICK AT LEAST FOUR SPECIES, INCLUDING ONE FROM EACH TYPE.			

TEMPORARY RIPARIAN/WETLAND SEED MIXTURE ACCORDING TO PLANTING PERIOD FOR PIEDMONT

COMMON NAME	RATE/ACRE	OPTIMAL PLANTING DATES
RYE GRAIN	30	AUG. 15 - MAY 1
WHEAT	30	AUG. 15 - MAY 1
GERMAN MILLET	10	MAY 1 - AUG. 15
BROWNTOP MILLET	10	MAY 1 - AUG. 15

- TEMPORARY SEEDING NOTES:**
- SINGLE SPECIES SELECTION FOR TEMPORARY COVER IS ACCEPTABLE.
 - IN SOME CASES WHERE SEASONS OVERLAP, A MIXTURE OF TWO OR MORE TEMPORARY SPECIES MAY BE NECESSARY.
 - APPLICATION RATES SHOULD NOT EXCEED TO THE TOTAL RECOMMENDED RATE PER ACRE.
 - TEMPORARY SEED SHOULD BE MIXED AND APPLIED SIMULTANEOUSLY WITH THE PERMANENT SEED MIX IF OPTIMAL PLANTING DATES ALLOW.

NCG01 GROUND STABILIZATION AND MATERIALS HANDLING

EFFECTIVE: 04/01/19

PART III SELF-INSPECTION, RECORDKEEPING AND REPORTING

SECTION A: SELF-INSPECTION

Self-inspections are required during normal business hours in accordance with the table below. When adverse weather or site conditions would cause the safety of the inspection personnel to be in jeopardy, the inspection may be delayed until the next business day on which it is safe to perform the inspection. In addition, when a storm event of equal to or greater than 1.0 inch occurs outside of normal business hours, the self-inspection shall be performed upon the commencement of the next business day. Any time when inspections were delayed shall be noted in the Inspection Record.

Inspect	Frequency (during normal business hours)	Inspection records must include:
(1) Rain gauge maintained in good working order	Daily	Daily rainfall amounts. If no daily rain gauge observations are made during weekend or holiday periods, and no individual day rainfall information is available, record the cumulative rain measurement for those unattended days (note this will determine if a site inspection is needed). Days on which no rainfall occurred shall be recorded as "zero". The permittee may use another rain-monitoring device approved by the Division.
(2) E&S Measures	At least once per 7 calendar days and within 24 hours of a rain event ≥ 1.0 inch in 24 hours	1. Identification of the measures inspected, 2. Date and time of the inspection, 3. Name of the person performing the inspection, 4. Indication of whether the measures were operating properly, 5. Description of maintenance needs for the measure, 6. Description, evidence, and date of corrective actions taken.
(3) Stormwater discharge outside (SDC)	At least once per 7 calendar days and within 24 hours of a rain event ≥ 1.0 inch in 24 hours	1. Identification of the discharge outfalls inspected, 2. Date and time of the inspection, 3. Name of the person performing the inspection, 4. Evidence of indicators of stormwater pollution such as oil sheen, floating or suspended solids or discoloration, 5. Indication of visible sediment leaving the site, 6. Description, evidence, and date of corrective actions taken.
(4) Perimeter of site	At least once per 7 calendar days and within 24 hours of a rain event ≥ 1.0 inch in 24 hours	If visible sedimentation is found outside site limits, then a record of the following shall be made: 1. Actions taken to clean up or stabilize the sediment that has left the site limits, 2. Description, evidence, and date of corrective actions taken, and 3. An explanation as to the actions taken to control future releases.
(5) Streams or wetlands onsite or offsite (where accessible)	At least once per 7 calendar days and within 24 hours of a rain event ≥ 1.0 inch in 24 hours	If the stream or wetland has increased visible sedimentation or a stream has visible increased turbidity from the construction activity, then a record of the following shall be made: 1. Description, evidence, and date of corrective actions taken, and 2. Records of the required reports to the appropriate Division Regional Office per Part III, Section C, Item 2(a) of this permit.
(6) Ground stabilization measures	After each phase of grading	1. The phase of grading, 2. Description, evidence, and date of corrective actions taken, 3. Documentation that the required ground stabilization measures have been provided within the required timeframe or an assurance that they will be provided as soon as possible.

NOTE: The rain inspection results the required 7 calendar day inspection requirement.

PART III SELF-INSPECTION, RECORDKEEPING AND REPORTING

SECTION B: RECORDKEEPING

1. E&S Plan Documentation
 The approved E&S plan as well as any approved deviation shall be kept on the site. The approved E&S plan must be kept up-to-date throughout the coverage under this permit. The following items pertaining to the E&S plan shall be kept on site and available for inspection at all times during normal business hours.

Item to Document	Documentation Requirements
(a) Each E&S measure has been installed and does not significantly deviate from the locations, dimensions and relative elevations shown on the approved E&S plan.	Initial and date each E&S measure on a copy of the approved E&S plan or complete, date and sign an inspection report that lists each E&S measure shown on the approved E&S plan. This documentation is required upon the initial installation of the E&S measures or if the E&S measures are modified after initial installation.
(b) A phase of grading has been completed.	Initial and date a copy of the approved E&S plan or complete, date and sign an inspection report to indicate completion of the construction phase.
(c) Ground cover is located and installed in accordance with the approved E&S plan.	Initial and date a copy of the approved E&S plan or complete, date and sign an inspection report to indicate compliance with approved ground cover specifications.
(d) The maintenance and repair requirements for all E&S measures have been performed.	Complete, date and sign an inspection report.
(e) Corrective actions have been taken to E&S measures.	Initial and date a copy of the approved E&S plan or complete, date and sign an inspection report to indicate the completion of the corrective action.

2. Additional Documentation to be Kept on Site

In addition to the E&S plan documents above, the following items shall be kept on the site and available for inspectors at all times during normal business hours, unless the Division provides a site-specific exemption based on unique site conditions that make this requirement not practical:

- This General Permit as well as the Certificate of Coverage, after it is received.
- Records of inspections made during the previous twelve months. The permittee shall record the required observations on the Inspection Record Form provided by the Division or a similar inspection form that includes all the required elements. Use of electronically-available records in lieu of the required paper copies will be allowed if shown to provide equal access and utility as the hard-copy records.

3. Documentation to be Retained for Three Years

All data used to complete the e-NOI and all inspection records shall be maintained for a period of three years after project completion and made available upon request. [40 CFR 122.41]

PART III SELF-INSPECTION, RECORDKEEPING AND REPORTING

SECTION C: REPORTING

1. Occurrences that Must be Reported

- Permittees shall report the following occurrences:
- Visible sediment deposition in a stream or wetland.
 - Oil spills if:
 - They are 25 gallons or more,
 - They are less than 25 gallons but cannot be cleaned up within 24 hours,
 - They cause sheen on surface waters (regardless of volume), or
 - They are within 100 feet of surface waters (regardless of volume).
 - Releases of hazardous substances in excess of reportable quantities under Section 311 of the Clean Water Act (Ref: 40 CFR 110.3 and 40 CFR 117.3) or Section 102 of CERCLA (Ref: 40 CFR 302.4) or G.S. 143-215.85.
 - Anticipated bypasses and unanticipated bypasses.
 - Noncompliance with the conditions of this permit that may endanger health or the environment.

2. Reporting Timeframes and Other Requirements

After a permittee becomes aware of an occurrence that must be reported, he shall contact the appropriate Division regional office within the timeframes and in accordance with the other requirements listed below. Occurrences outside normal business hours may also be reported to the Department's Environmental Emergency Center personnel at (800) 858-0566.

Occurrence	Reporting Timeframes (After Discovery) and Other Requirements
(a) Visible sediment deposition in a stream or wetland	<ul style="list-style-type: none"> Within 24 hours, an oral or electronic notification. Within 7 calendar days, a report that contains a description of the sediment and actions taken to address the cause of the deposition. Division staff may waive the requirement for a written report on a case-by-case basis. If the stream is named on the NC 303(d) list as impaired for sediment-related causes, the permittee may be required to perform additional monitoring. Inspections or apply more stringent actions if staff determine that additional requirements are needed to assure compliance with the federal or state impaired-waters conditions.
(b) Oil spills and release of hazardous substances per Item 1(b)-(c) above	<ul style="list-style-type: none"> Within 24 hours, an oral or electronic notification. The notification shall include information about the date, time, nature, volume and location of the spill or release.
(c) Anticipated bypasses (40 CFR 122.41(m)(3))	<ul style="list-style-type: none"> A report at least ten days before the date of the bypass, if possible. The report shall include an evaluation of the anticipated quality and effect of the bypass.
(d) Unanticipated bypasses (40 CFR 122.41(m)(3))	<ul style="list-style-type: none"> Within 24 hours, an oral or electronic notification. Within 7 calendar days, a report that includes an evaluation of the quality and effect of the bypass.
(e) Noncompliance with the conditions of this permit that may endanger health or the environment (40 CFR 122.41(l)(7))	<ul style="list-style-type: none"> Within 24 hours, an oral or electronic notification. Within 7 calendar days, a report that contains a description of the noncompliance, and its causes; the period of noncompliance, including exact dates and times, and if the noncompliance has not been corrected, the anticipated time noncompliance is expected to continue; and steps taken or planned to reduce, eliminate, and prevent recurrence of the noncompliance. (40 CFR 122.41(l)(6)). Division staff may waive the requirement for a written report on a case-by-case basis.



NCG01 SELF-INSPECTION, RECORDKEEPING AND REPORTING

EFFECTIVE: 04/01/19

2 RIPARIAN/WETLAND SEEDING

- PERMANENT SEEDING NOTES:**
- SEED:**
- NO SPECIFIC SEEDING RATE IS GIVEN IN ORDER TO ALLOW FOR CUSTOM SEED MIXES BASED ON SITE CHARACTERISTICS AND SEASON.
 - HOWEVER, PERMANENT SEED INCLUSION IN THE MIXTURE SHOULD TOTAL 15 POUNDS OF PURE LIVE SEED (PLS) PER ACRE DRILLED OR 15 TO 20 POUNDS PLS PER ACRE BROADCAST APPLIED.
 - SELECTION OF FOUR OR MORE SPECIES IS RECOMMENDED FOR INCREASING CHANCES OF SUCCESSFUL VEGETATION ESTABLISHMENT.
 - IF OTHER SPECIES SUCH AS WILDFLOWERS ARE ADDED TO THE MIX, THEY SHOULD NOT BE COUNTED IN THE MINIMUM SEEDING RATE FOR GRASSES.
 - APPLY SEED UNIFORMLY WITH A CYCLONE SEEDER, DROP-TYPE SPREADER, DRILL OR HYDROSEEDER ON A FIRM, FRIABLE SEEDBED. WHEN USING A DRILL, EQUIPMENT SHOULD BE CALIBRATED IN THE FIELD FOR THE DESIRED SEEDING RATE.
- FERTILIZER:**
- APPROPRIATE PH LEVELS ARE BETWEEN 5.5 AND 7. APPLIED LEVELS OF PHOSPHORUS AND POTASSIUM SHOULD BE ADJUSTED GIVEN LOCAL SOIL CHARACTERISTICS.

NOTE: ALL CONSTRUCTION SHALL ADHERE TO CITY OF RALEIGH STANDARDS AND SPECIFICATIONS
 CITY OF RALEIGH - PLANS AUTHORIZED FOR CONSTRUCTION

Plans for the proposed use have been reviewed for general compliance with applicable codes. This limited review, and authorization for construction is not to be considered to represent total compliance with all legal requirements for development and construction. The property owner, design consultants, and contractors are each responsible for compliance with all applicable City, State and Federal laws. This specific authorization below is not a permit, nor shall it be construed to permit any violation of City, State or Federal Law. All construction must be in accordance with all Local, State, and Federal Rules and Regulations. This approval of this electronic document is only valid if the document has not been modified and the digital signature below is valid:

PROJECT NO. CSE2201
 ED-2.0
 City of Raleigh Development Approval

Professional Engineer Seal for Brian J.P. Oscawald, No. 038689, State of North Carolina.

Logo for Highfill Infrastructure Engineering, P.C., located at 2703 Jones Franklin Rd, Suite 201, Cary, NC 27518.

Engineering is our profession. Service is our passion.

CD 22-06
 WALLBROOK OFFSITE UTILITY IMPROVEMENTS
 WALLBROOK LANDCO ROLESVILLE, NC
 EROSION CONTROL DETAILS

PRELIMINARY DESIGN NOT RELEASED FOR CONSTRUCTION

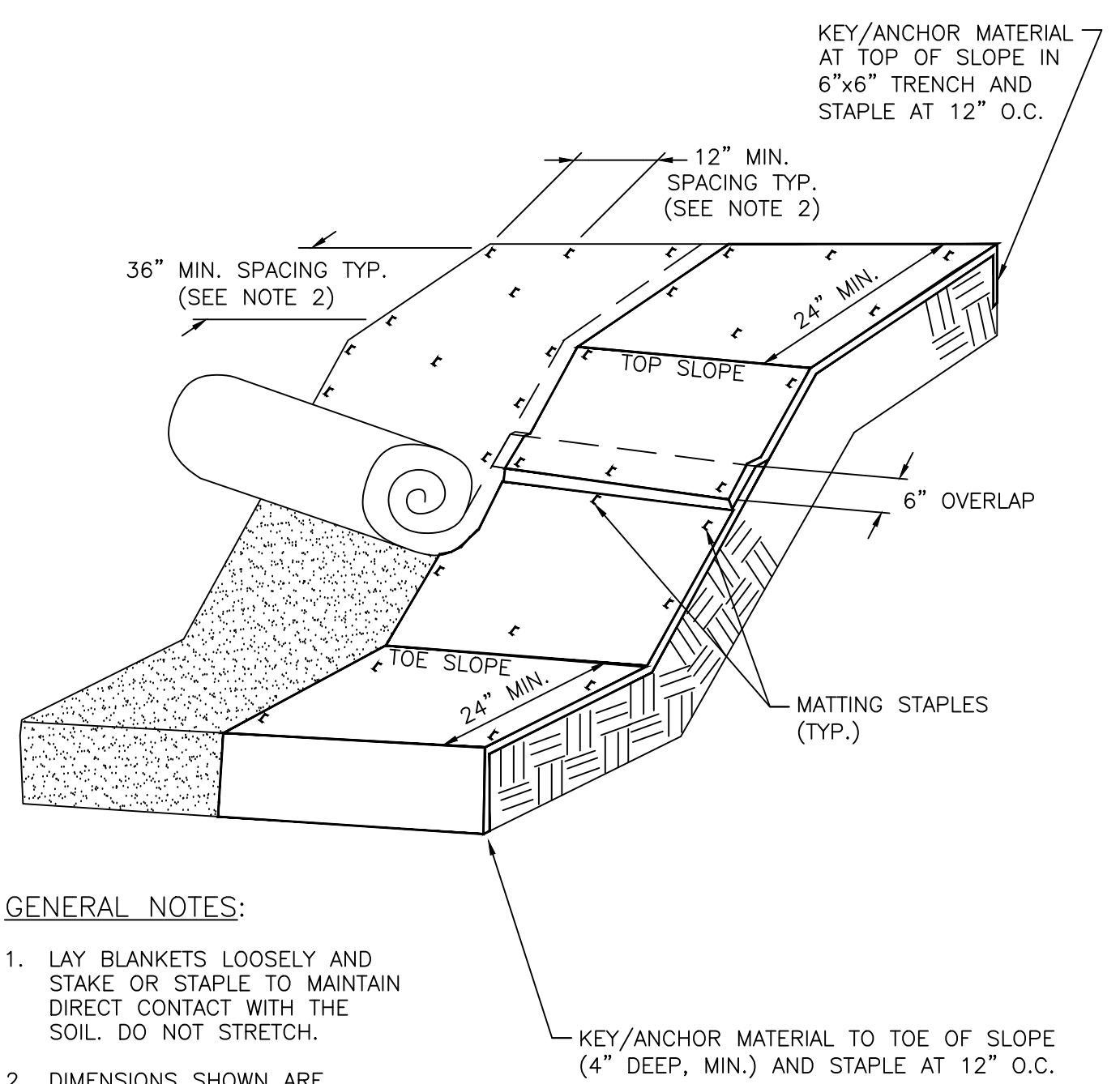

- GENERAL NOTES:**
- LAY BLANKETS LOOSELY AND STAKE OR STAPLE TO MAINTAIN DIRECT CONTACT WITH THE SOIL. DO NOT STRETCH.
 - DIMENSIONS SHOWN ARE MINIMUM. MANUFACTURED PRODUCTS MAY HAVE ADDITIONAL REQUIREMENTS THAT MUST BE MET.
 - SLOPE SURFACE SHALL BE FREE OF ROCKS, SOIL CLODS, STICKS, GRASS. MAT/BLANKETS SHALL HAVE GOOD SOIL CONTACT.
 - THE DETAIL SHOWN IS FOR SLOPE MATTING, NOT FOR CHANNEL MATTING.

31-06	SLOPE STABILITY W/EROSION CONTROL MATTING
HEPC DETAIL I.D.	NO SCALE
REVISED DATE	11/1/2016

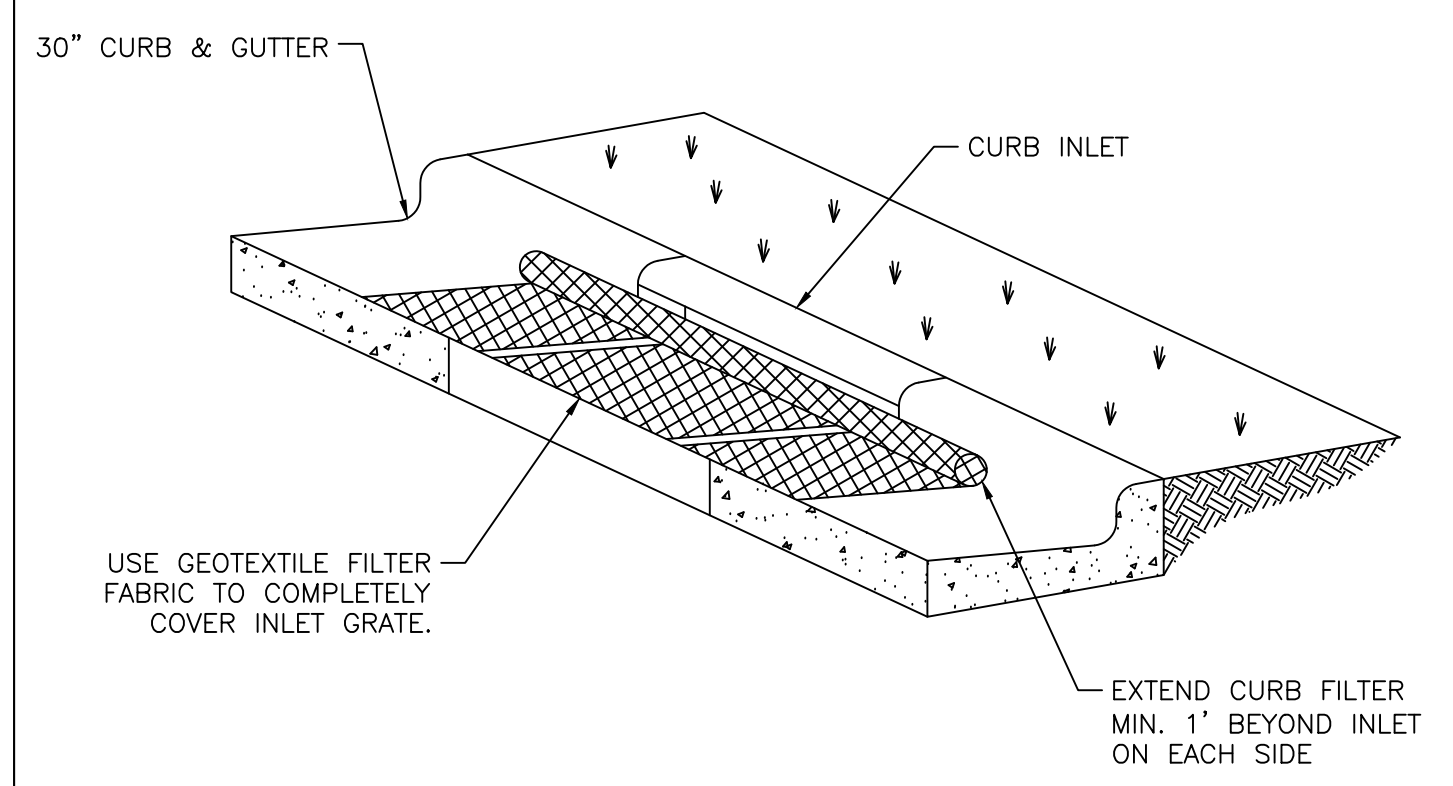

NOTE:
IF CURB INLET DOES NOT INCLUDE INLET GRATE, INSTALL CURB FILTER ONLY.

31-15	CURB FILTER INLET PROTECTION
HEPC DETAIL I.D.	NO SCALE
REVISED DATE	11/1/2016

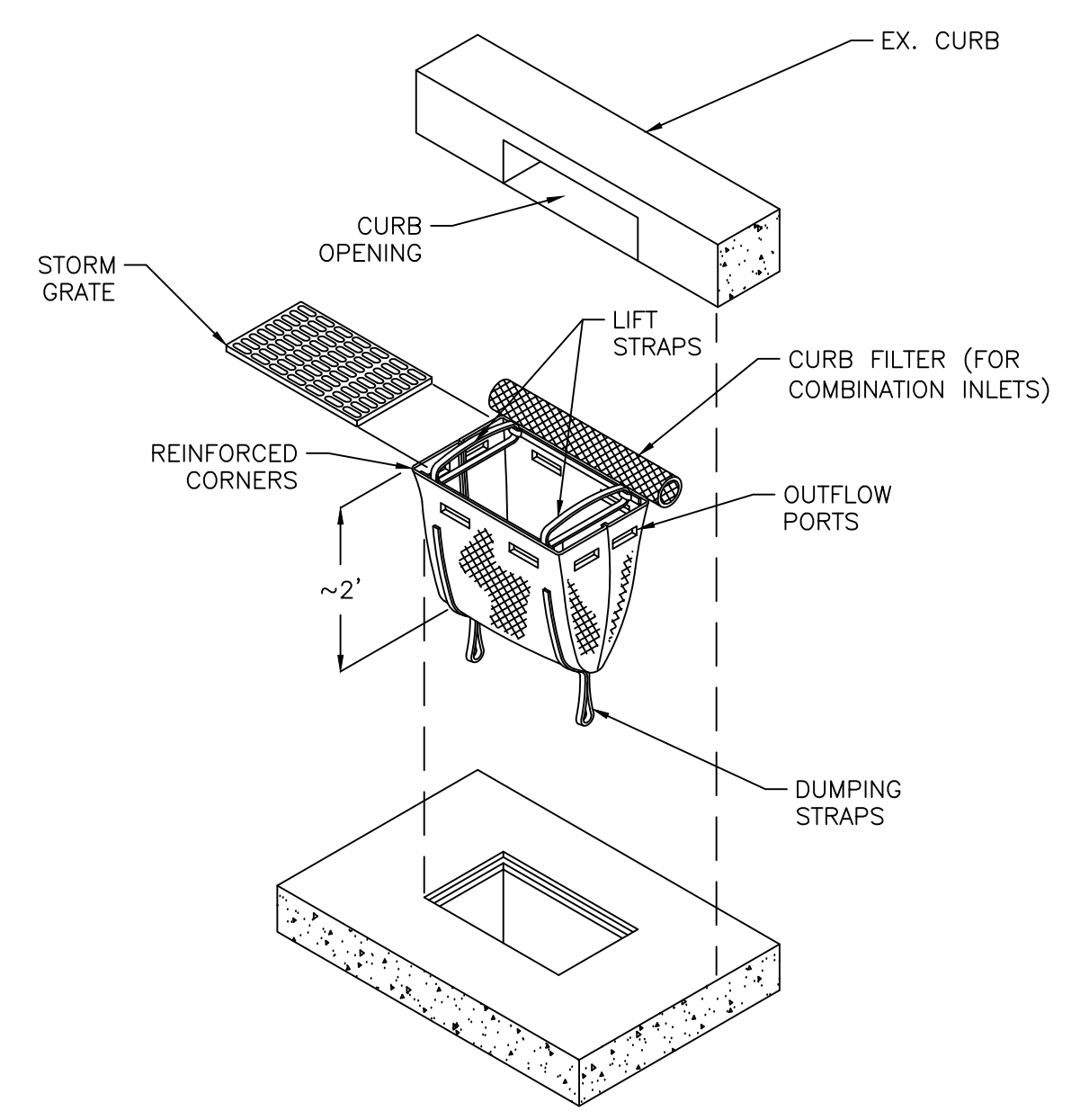

31-15A	CURB INLET FILTER SACK
HEPC DETAIL I.D.	NO SCALE
REVISED DATE	5/16/2018

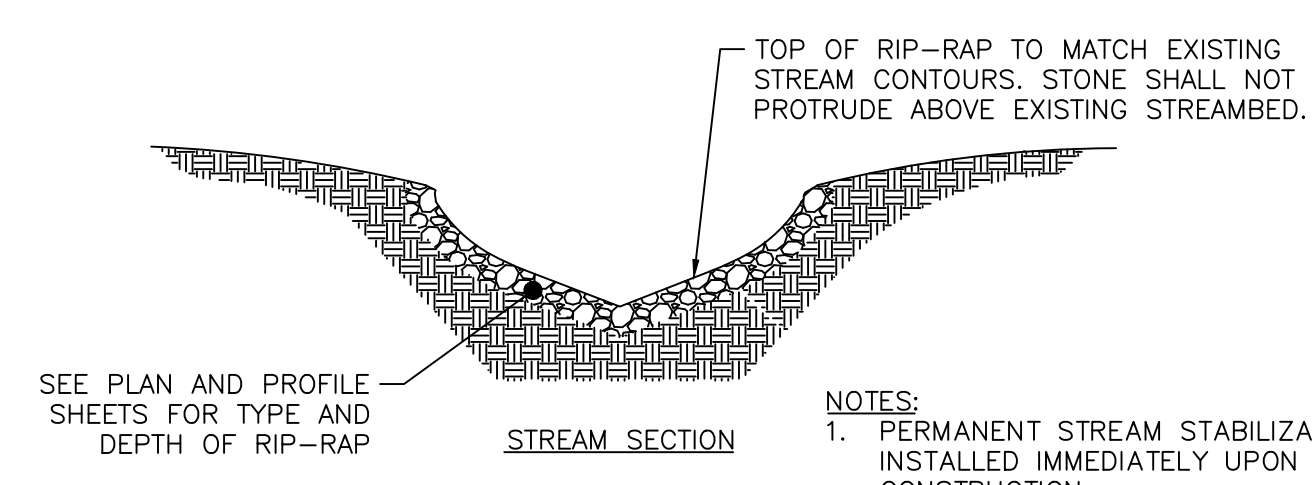

- NOTES:**
- PERMANENT STREAM STABILIZATION SHALL BE INSTALLED IMMEDIATELY UPON COMPLETION OF CONSTRUCTION.
 - RIP-RAP SHALL BE INSTALLED FROM TOP OF BANK TO TOP OF BANK, ACROSS ENTIRE WIDTH OF DISTURBED STREAM.

EROSION CONTROL MAINTENANCE PLAN

ALL EROSION CONTROL MEASURES SHALL BE INSPECTED WEEKLY AND AFTER EACH SIGNIFICANT RAINFALL. ALL NEEDED REPAIRS SHALL BE MADE IMMEDIATELY TO PREVENT FURTHER DAMAGE AND EROSION. STRUCTURES AND MEASURES THAT SHALL BE INSPECTED INCLUDE:

- MATTING, SEEDING, FERTILIZING, AND MULCHING: SEEDED AREAS SHALL BE INSPECTED FOR FAILURE AND NECESSARY REPAIRS SHALL BE MADE WITHIN THE SAME SEASON. REPLACE OR REPAIR MATTING AS NECESSARY TO ENSURE SLOPE STABILITY.
- CONSTRUCTION ENTRANCE: MAINTAIN THE GRAVEL PAD IN A CONDITION TO PREVENT MUD OR SEDIMENT FROM LEAVING THE CONSTRUCTION SITE. THIS MAY REQUIRE PERIODIC TOPDRESSING WITH 2-INCH STONE AFTER EACH RAINFALL. INSPECT ANY STRUCTURE USED TO TRAP SEDIMENT AND CLEAN IT OUT AS NECESSARY. IMMEDIATELY REMOVE ALL OBJECTIONABLE MATERIALS SPILLED, WASHED OR TRACKED ONTO PUBLIC ROADWAYS.
- SILT FENCE: ANY FABRIC WHICH COLLAPSES, TEARS, DECOMPOSES, OR BECOMES INEFFECTIVE WILL BE REPLACED IMMEDIATELY. REMOVE SEDIMENT DEPOSITS BEHIND FENCE WHEN SEDIMENT ACCUMULATES TO 6".
- SILT FENCE OUTLET: REMOVE SEDIMENT WHEN HALF OF STONE OUTLET IS COVERED. REPLACE STONE AS NEEDED TO ENSURE DEWATERING.
- SILT BAG: ANY FABRIC WHICH COLLAPSES, TEARS, DECOMPOSES, OR BECOMES INEFFECTIVE WILL BE REPLACED IMMEDIATELY. REPLACE SILT BAG WHEN ONE HALF (½) FULL OF SEDIMENT.
- ROCK CHECK DAMS AND ROCK PIPE INLET PROTECTION: INSPECT FOR SIGNIFICANT EROSION AROUND THE EDGES AND BETWEEN DAMS. INSTALL PROTECTIVE RIP RAP LINERS IN PORTIONS OF THE CHANNEL WHERE EROSION OCCURS. REMOVE SEDIMENT ACCUMULATED BEHIND THE DAMS AS REQUIRED TO PREVENT DAMAGE TO CHANNEL VEGETATION. ADD STONES TO DAMS AS REQUIRED TO MAINTAIN DESIGN HEIGHT AND CROSS SECTION.
- STOCKPILES: STOCKPILES SHALL BE CHECKED FOR SEDIMENTATION AND STABILIZATION.
- DIVERSION DITCH: INSPECT FOR ANY EROSION ON THE RIDGE AND IN THE FLOW AREAS. REMOVE SEDIMENT WHEN SEDIMENT ACCUMULATES TO 4".
- FABRIC INLET PROTECTION: ANY FABRIC WHICH COLLAPSES, TEARS, DECOMPOSES, OR BECOME INEFFECTIVE WILL BE REPLACED IMMEDIATELY. REMOVE SEDIMENT DEPOSITS BEHIND FENCE WHEN SEDIMENT ACCUMULATES TO SIX INCHES.
- WATTLE: THE CONTRACTOR SHALL MAINTAIN THE WATTLES UNTIL THE PROJECT IS ACCEPTED OR UNTIL THE WATTLES ARE REMOVED, AND SHALL REMOVE AND DISPOSE OF SILT ACCUMULATIONS AT THE WATTLES WHEN SO DIRECTED IN ACCORDANCE WITH THE REQUIREMENTS OF SECTION 1630 OF THE NCDOT STANDARD SPECIFICATIONS.
- TEMPORARY SEDIMENT TRAP: INSPECT TEMPORARY SEDIMENT TRAPS AT LEAST WEEKLY AND AFTER EACH SIGNIFICANT (ONE-HALF INCH OR GREATER) RAINFALL EVENT AND REPAIR IMMEDIATELY. REMOVE SEDIMENT, AND RESTORE THE TRAP TO ITS ORIGINAL DIMENSIONS WHEN THE SEDIMENT HAS ACCUMULATED TO ONE-HALF THE DESIGN DEPTH OF THE TRAP. PLACE THE SEDIMENT THAT IS REMOVED IN THE DESIGNATED DISPOSAL AREA, AND REPLACE THE PART OF THE GRAVEL FACING THAT IS IMPAIRED BY SEDIMENT. CHECK THE STRUCTURE FOR DAMAGE FROM EROSION OR PIPING. PERIODICALLY CHECK THE DEPTH OF THE SPILLWAY TO ENSURE IT IS A MINIMUM OF 1.5 FEET BELOW THE LOW POINT OF THE EMBANKMENT. IMMEDIATELY FILL ANY SETTLEMENT OF THE EMBANKMENT TO SLIGHTLY ABOVE DESIGN GRADE. ANY RIPRAP DISPLACED FROM THE SPILLWAY MUST BE REPLACED IMMEDIATELY. AFTER ALL SEDIMENT-PRODUCING AREAS HAVE BEEN PERMANENTLY STABILIZED, REMOVE THE STRUCTURE AND ALL UNSTABLE SEDIMENT. SMOOTH THE AREA TO BLEND WITH THE ADJOINING AREAS, AND STABILIZE PROPERLY.

1 PERMANENT STREAM STABILIZATION

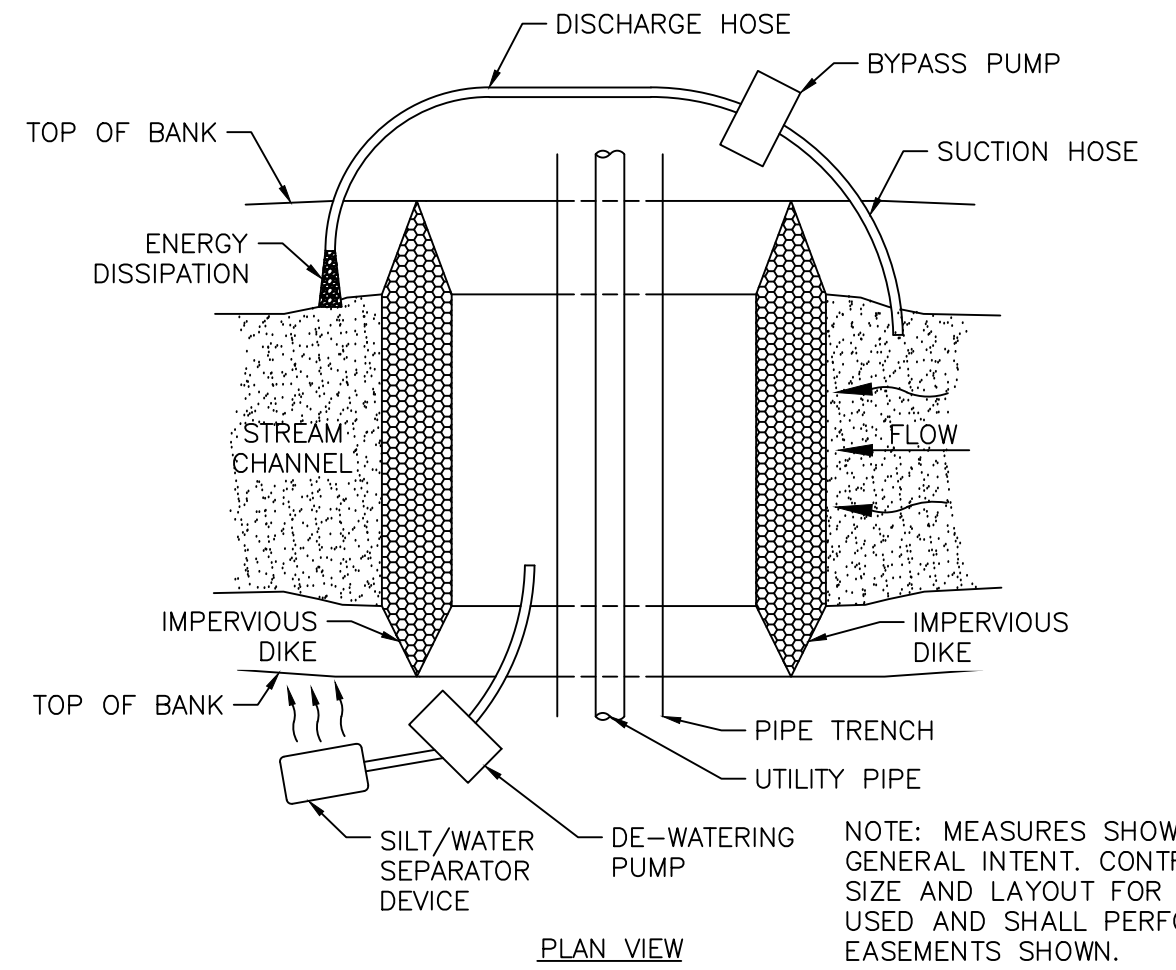

NOTE: MEASURES SHOWN ARE TO CONVEY THE GENERAL INTENT. CONTRACTOR SHALL DETERMINE SIZE AND LAYOUT FOR MEANS AND METHODS USED AND SHALL PERFORM ALL WORK WITHIN EASEMENTS SHOWN.

2 UTILITY STREAM CROSSING W/DAM AND PUMPING

3 EROSION CONTROL MAINTENANCE PLAN

DATE	10/28/22	BY	GDF
REVISION	90% DESIGN 1ST SUBMITTAL TO TRC		
	2ND SUBMITTAL TO TRC		
	3RD SUBMITTAL TO TRC		
	02/24/22		MWC



HIGHFILL
INFRASTRUCTURE
ENGINEERING, P.C.

2703 Jones Franklin Rd, Suite 201
Cary, NC 27518
Tel 919-481-4342
Fax 919-882-9762
www.hiepc.com
Firm License No. C-2586

*Engineering is our profession.
Service is our passion.*

WALLBROOK OFFSITE UTILITY IMPROVEMENTS
WALLBROOK LANDCO
ROLESVILLE, NC

EROSION CONTROL DETAILS

NOTE: ALL CONSTRUCTION SHALL ADHERE TO CITY OF RALEIGH STANDARDS AND SPECIFICATIONS

CITY OF RALEIGH - PLANS AUTHORIZED FOR CONSTRUCTION

Plans for the proposed use have been reviewed for general compliance with applicable codes. This limited review, and authorization for construction is not to be considered to represent total compliance with all legal requirements for development and construction. The property owner, design consultants, and contractors are each responsible for compliance with all applicable City, State and Federal laws. This specific authorization below is not a permit, nor shall it be construed to permit any violation of City, State or Federal Law. All construction must be in accordance with all Local, State, and Federal Rules and Regulations. This approval of this electronic document is only valid if the document has not been modified and the digital signature below is valid:

City of Raleigh Development Approval _____

PROJECT NO.
CSE2201

ED-3.0

CD 22-06

PRELIMINARY DESIGN NOT RELEASED FOR CONSTRUCTION

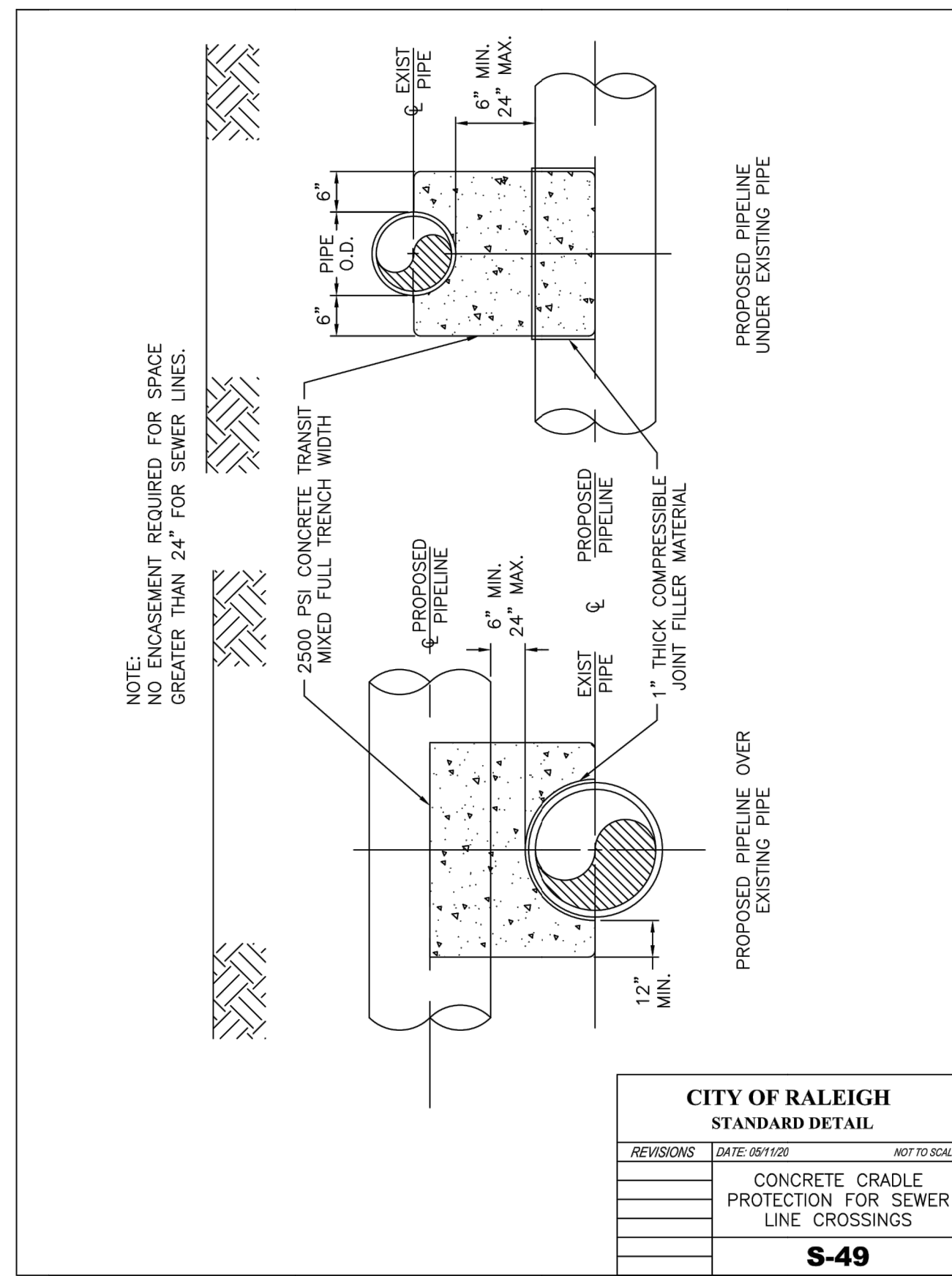

CITY OF RALEIGH
STANDARD DETAIL

REVISIONS	DATE	BY	NOT TO SCALE
	05/11/20		
CONCRETE CRADLE PROTECTION FOR SEWER LINE CROSSINGS			
S-49			

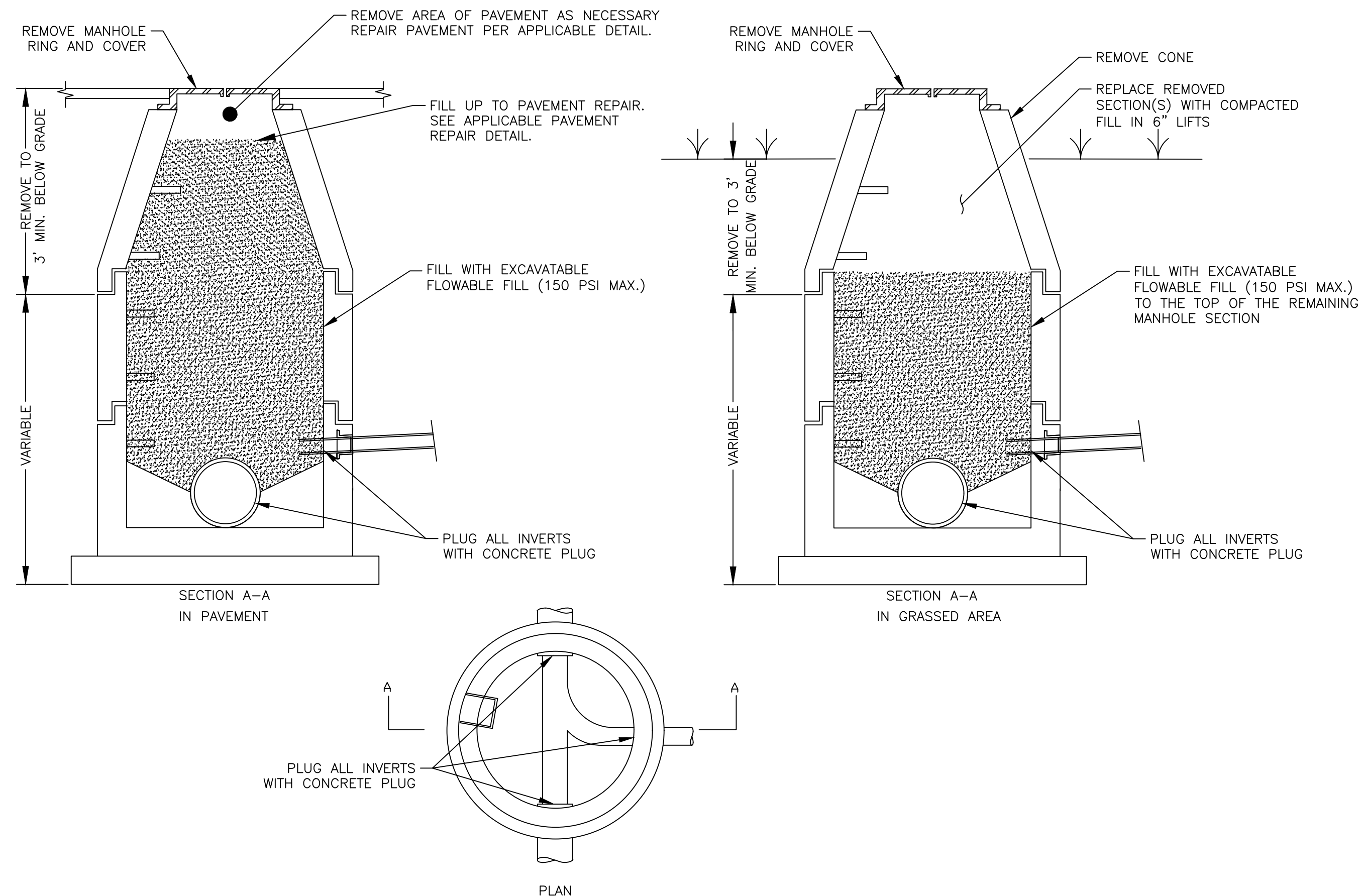

1 DETAIL – ABANDON EX. MANHOLE
NTS

NOTE: ALL CONSTRUCTION SHALL ADHERE TO CITY OF RALEIGH STANDARDS AND SPECIFICATIONS
CITY OF RALEIGH - PLANS AUTHORIZED FOR CONSTRUCTION

Plans for the proposed use have been reviewed for general compliance with applicable codes. This limited review, and authorization for construction is not to be considered to represent total compliance with all legal requirements for development and construction. The property owner, design consultants, and contractors are each responsible for compliance with all applicable City, State and Federal laws. This specific authorization below is not a permit, nor shall it be construed to permit any violation of City, State or Federal Law. All construction must be in accordance with all Local, State, and Federal Rules and Regulations. This approval of this electronic document is only valid if the document has not been modified and the digital signature below is valid.

City of Raleigh Development Approval _____

PRELIMINARY DESIGN NOT RELEASED FOR CONSTRUCTION

DATE	10/28/22	BY	GDF
DATE	12/29/22	BY	JV
DATE	02/24/22	BY	MWC
3RD SUBMITTAL TO TRC			
2ND SUBMITTAL TO TRC			
90% DESIGN 1ST SUBMITTAL TO TRC			
REVISION			

SEAL 038689
ENGINEER
BRIAN J.P. OSCHWALD
SEAL NOT VALID UNLESS SIGNED AND DATED

HIGHFILL
INFRASTRUCTURE
ENGINEERING, P.C.

2703 Jones Franklin Rd, Suite 201
Cary, NC 27518
Tel 919-481-4342
Fax 919-882-9762
www.hiepc.com
Firm License No. C-2586

*Engineering is our profession.
Service is our passion.*

CD 22-06

WALLBROOK OFFSITE UTILITY IMPROVEMENTS
WALLBROOK LANDCO
ROLESVILLE, NC

STANDARD DETAILS

PROJECT NO.
CSE2201

SD-2.0

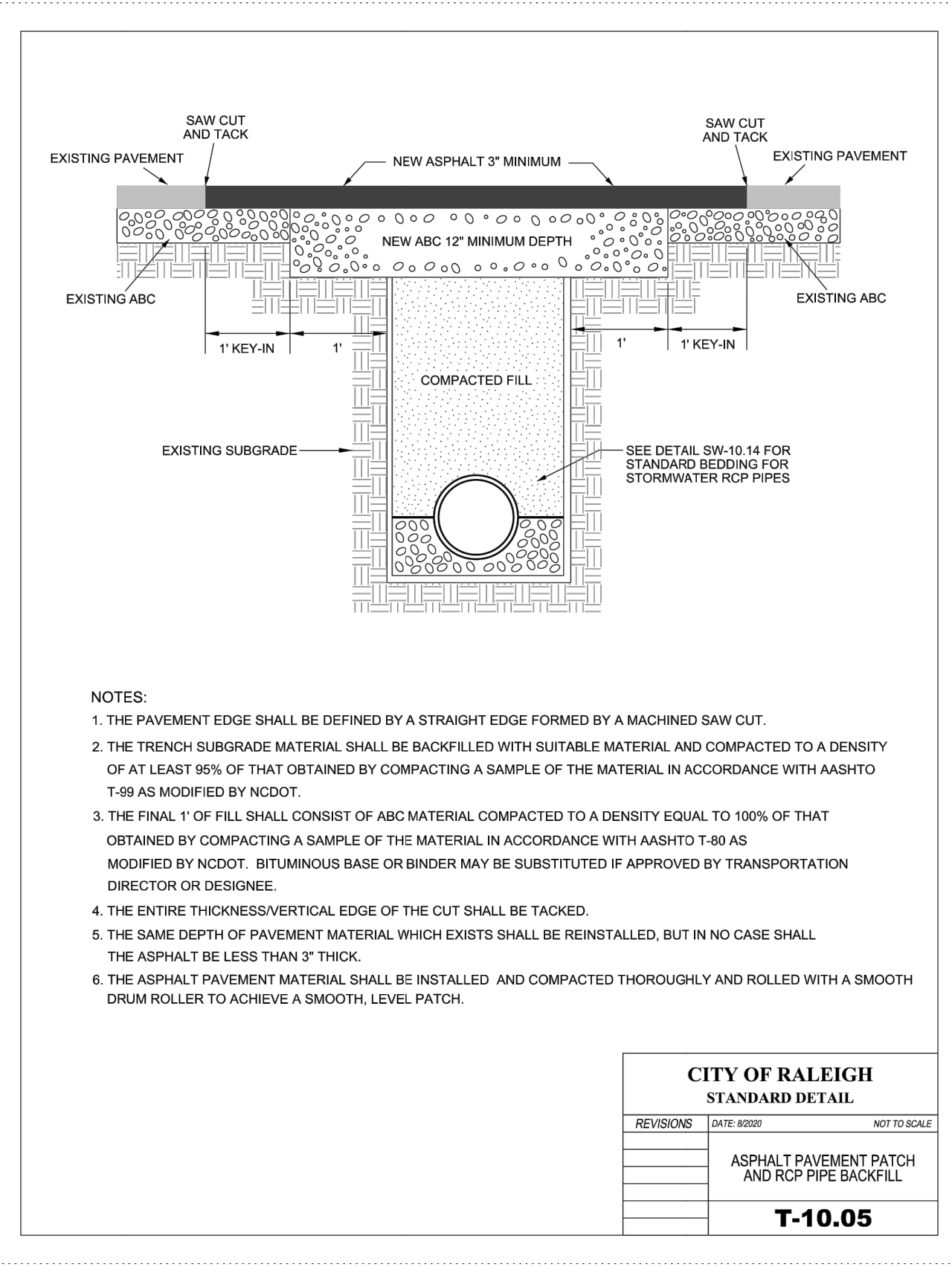

- NOTES:
1. THE PAVEMENT EDGE SHALL BE DEFINED BY A STRAIGHT EDGE FORMED BY A MACHINED SAW CUT.
 2. THE TRENCH SUBGRADE MATERIAL SHALL BE BACKFILLED WITH SUITABLE MATERIAL AND COMPACTED TO A DENSITY OF AT LEAST 95% OF THAT OBTAINED BY COMPACTING A SAMPLE OF THE MATERIAL IN ACCORDANCE WITH AASHTO T-99 AS MODIFIED BY NCDOT.
 3. THE FINAL 1\"/>

CITY OF RALEIGH STANDARD DETAIL		
REVISIONS	DATE	NOT TO SCALE
ASPHALT PAVEMENT PATCH AND RCP PIPE BACKFILL		
T-10.05		

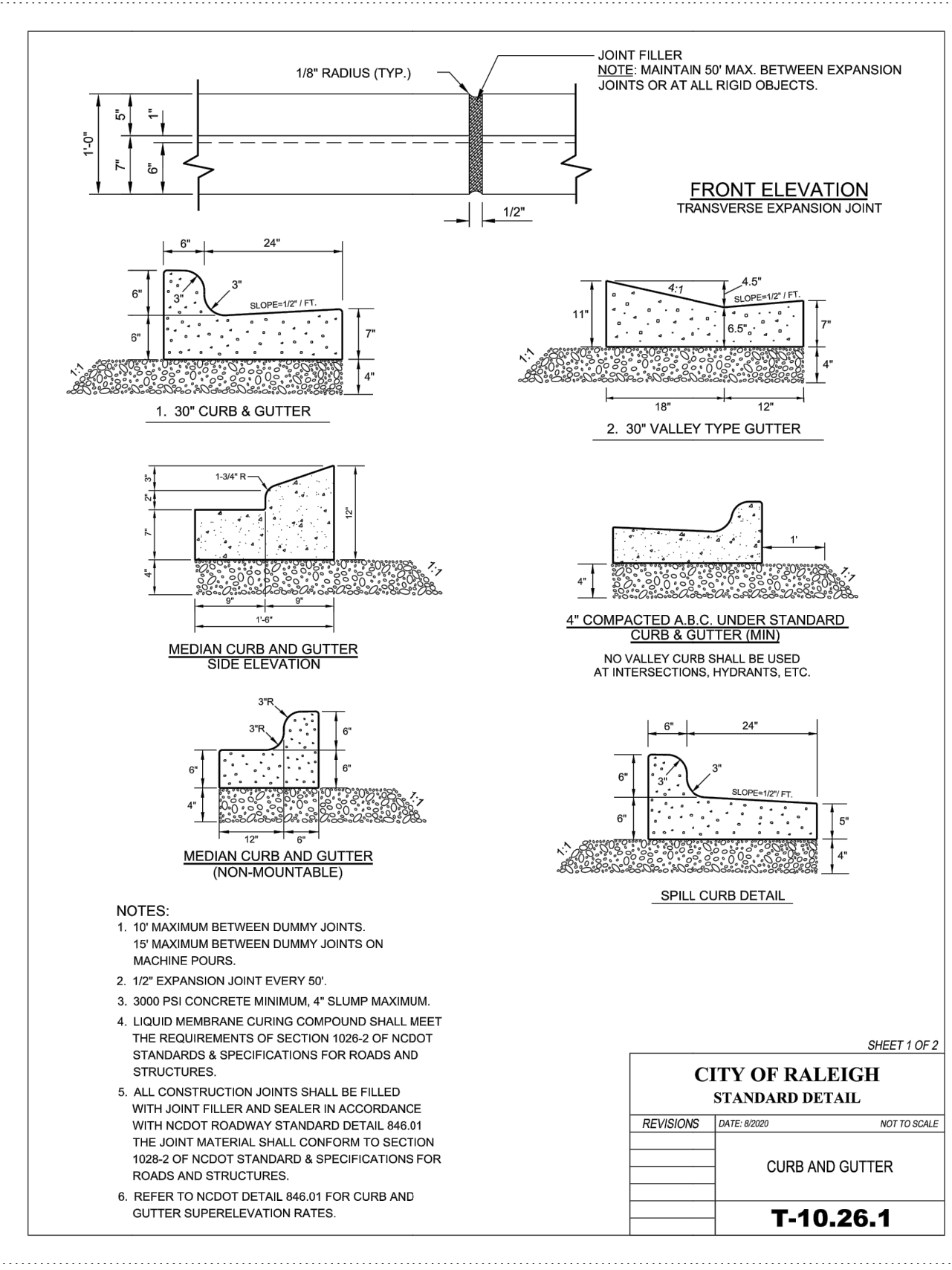

- NOTES:
1. 10\"/>

CITY OF RALEIGH STANDARD DETAIL		
REVISIONS	DATE	NOT TO SCALE
CURB AND GUTTER		
T-10.26.1		

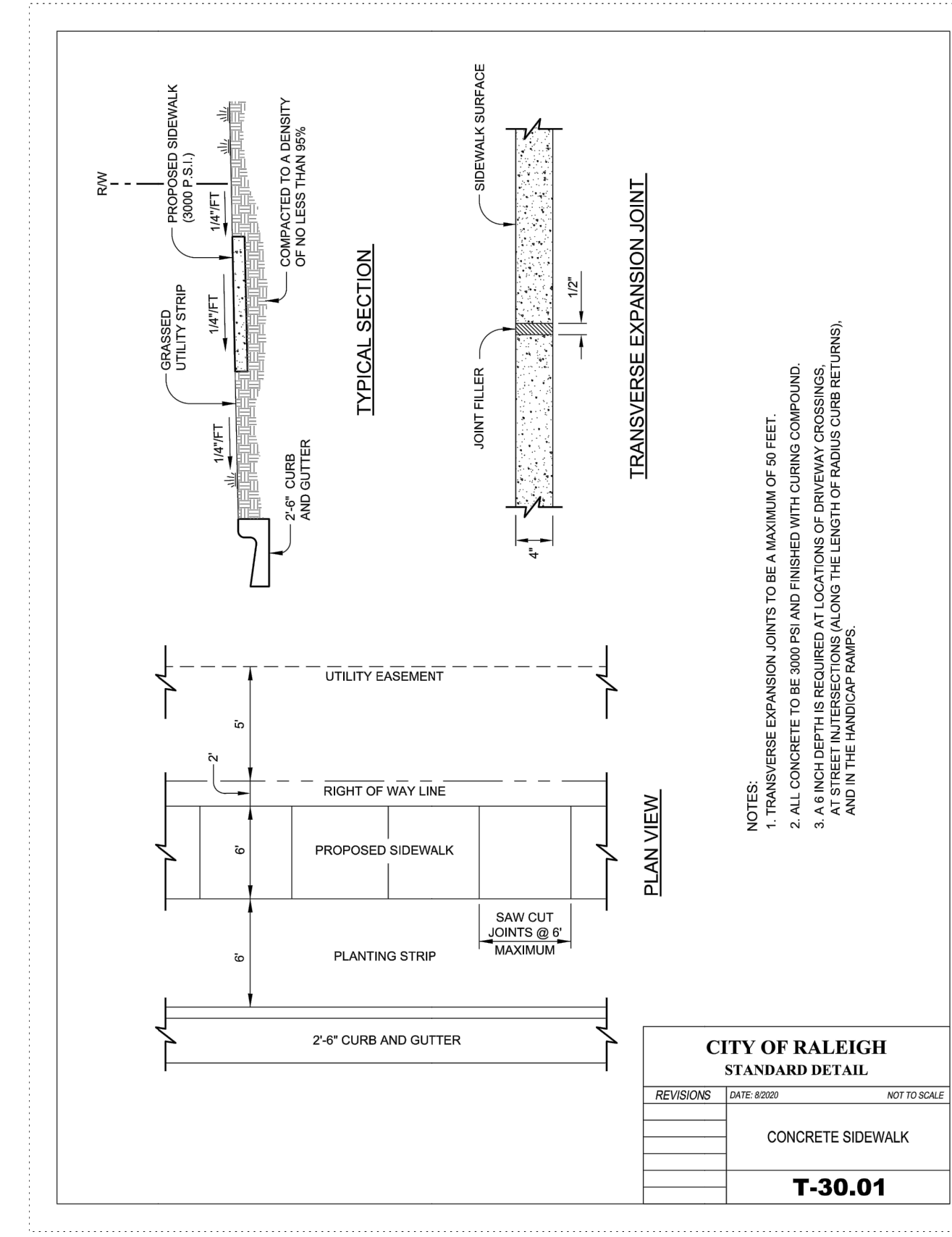

- NOTES:
1. TRANSVERSE EXPANSION JOINTS TO BE A MAXIMUM OF 50 FEET.
 2. ALL CONCRETE TO BE 3000 PSI AND FINISHED WITH CURING COMPOUND.
 3. A 4\"/>

CITY OF RALEIGH STANDARD DETAIL		
REVISIONS	DATE	NOT TO SCALE
CONCRETE SIDEWALK		
T-30.01		

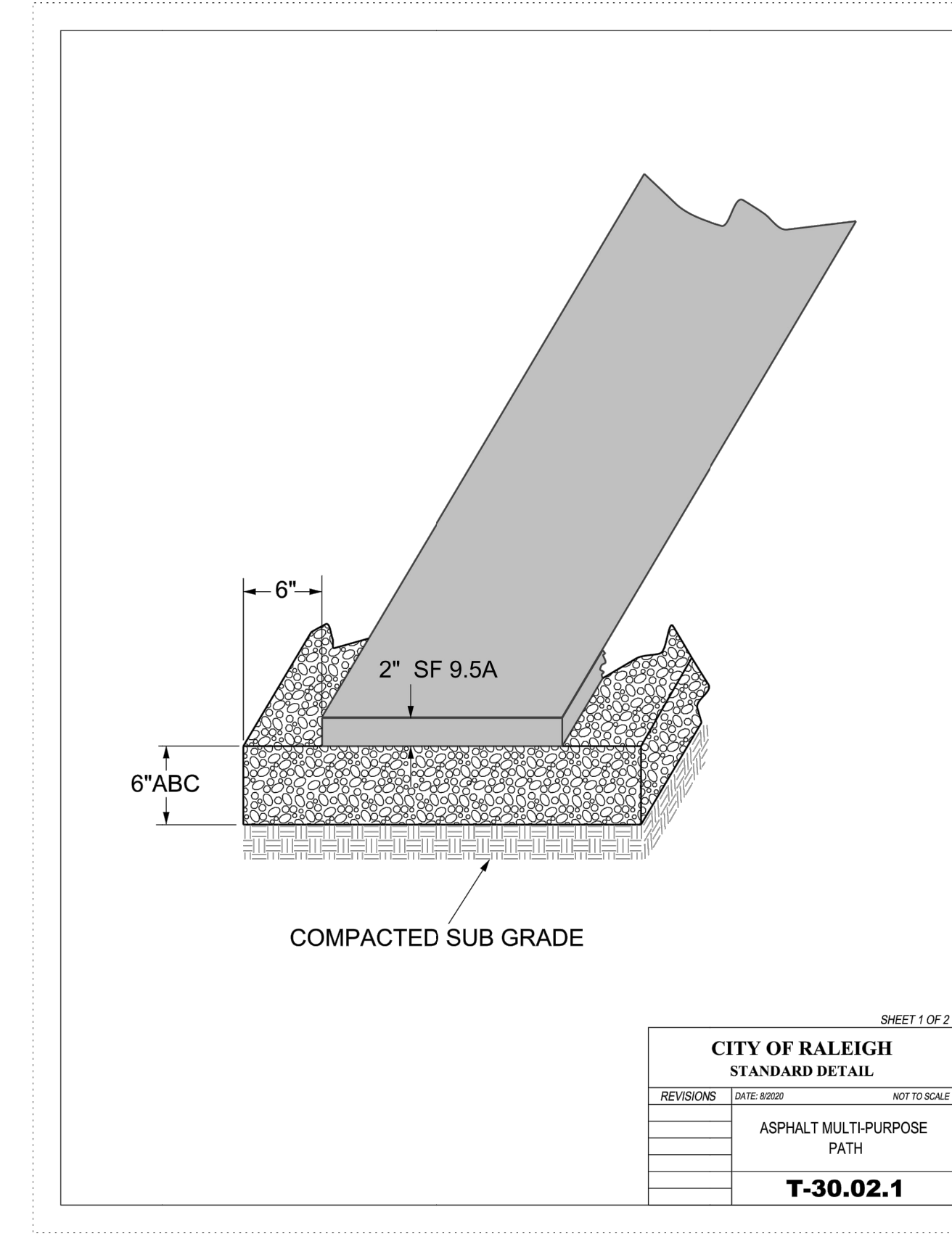

CITY OF RALEIGH STANDARD DETAIL		
REVISIONS	DATE	NOT TO SCALE
ASPHALT MULTI-PURPOSE PATH		
T-30.02.1		

NOTE: ALL CONSTRUCTION SHALL ADHERE TO
CITY OF RALEIGH STANDARDS AND SPECIFICATIONS
CITY OF RALEIGH - PLANS AUTHORIZED FOR CONSTRUCTION

Plans for the proposed use have been reviewed for general compliance with applicable codes. This limited review, and authorization for construction is not to be considered to represent total compliance with all legal requirements for development and construction. The property owner, design consultants, and contractors are each responsible for compliance with all applicable City, State and Federal laws. This specific authorization below is not a permit, nor shall it be construed to permit any violation of City, State or Federal Law. All construction must be in accordance with all Local, State, and Federal Rules and Regulations. This approval of this electronic document is only valid if the document has not been modified and the digital signature below is valid.

CD 22-06

WALLBROOK OFFSITE UTILITY IMPROVEMENTS
WALLBROOK LANDCO
ROLESVILLE, NC

TRAFFIC CONTROL DETAILS

PROJECT NO.
CSE2201

TD-1.0

DATE	REVISION	BY
10/28/22	90% DESIGN 1ST SUBMITTAL TO TRC	GDF
12/29/22	2ND SUBMITTAL TO TRC	JV
02/24/23	3RD SUBMITTAL TO TRC	MWC



HIGHFILL
INFRASTRUCTURE
ENGINEERING, P.C.

2703 Jones Franklin Rd, Suite 201
Cary, NC 27518
Tel 919-481-4342
Fax 919-882-9762
www.hiepc.com
Firm License No. C-2586

*Engineering is our profession.
Service is our passion.*

PRELIMINARY DESIGN NOT RELEASED FOR CONSTRUCTION

Table 6H-2. Meaning of Symbols on Typical Application Diagrams

	Arrow board		Shadow vehicle
	Arrow board support or trailer (shown facing down)		Sign (shown facing left)
	Changeable message sign or support trailer		Surveyor
	Channelizing device		Temporary barrier
	Crash cushion		Traffic or pedestrian signal
	Direction of temporary traffic detour		Truck-mounted attenuator
	Direction of traffic		Type 3 barricade
	Flagger		Warning light
	High-level warning device (Flag tree)		Work space
	Longitudinal channelizing device		Work vehicle
	Luminaire		
	Pavement markings that should be removed for a long-term project		

Table 6H-3. Meaning of Letter Codes on Typical Application Diagrams

Road Type	Distance Between Signs**		
	A	B	C
Urban (low speed)*	100 feet	100 feet	100 feet
Urban (high speed)*	350 feet	350 feet	350 feet
Rural	500 feet	500 feet	500 feet
Expressway / Freeway	1,000 feet	1,500 feet	2,640 feet

* Speed category to be determined by highway agency.
 ** The column headings A, B, and C are the dimensions shown in Figures 6H-1 through 6H-4. The A dimension is the distance from the transition or point of restriction to the first sign. The B dimension is the distance between the first and second signs. The C dimension is the distance between the second and third signs. (The "first sign" is the sign in a three-sign series that is closest to the TTC zone. The "third sign" is the sign that is furthest upstream from the TTC zone.)

Table 6H-4. Formulas for Determining Taper Length

Speed (S)	Taper Length (L) in feet
40 mph or less	$L = \frac{WS^2}{60}$
45 mph or more	$L = WS$

Where: L = taper length in feet
 W = width of offset in feet
 S = posted speed limit, or off-peak 85th-percentile speed prior to work starting, or the anticipated operating speed in mph

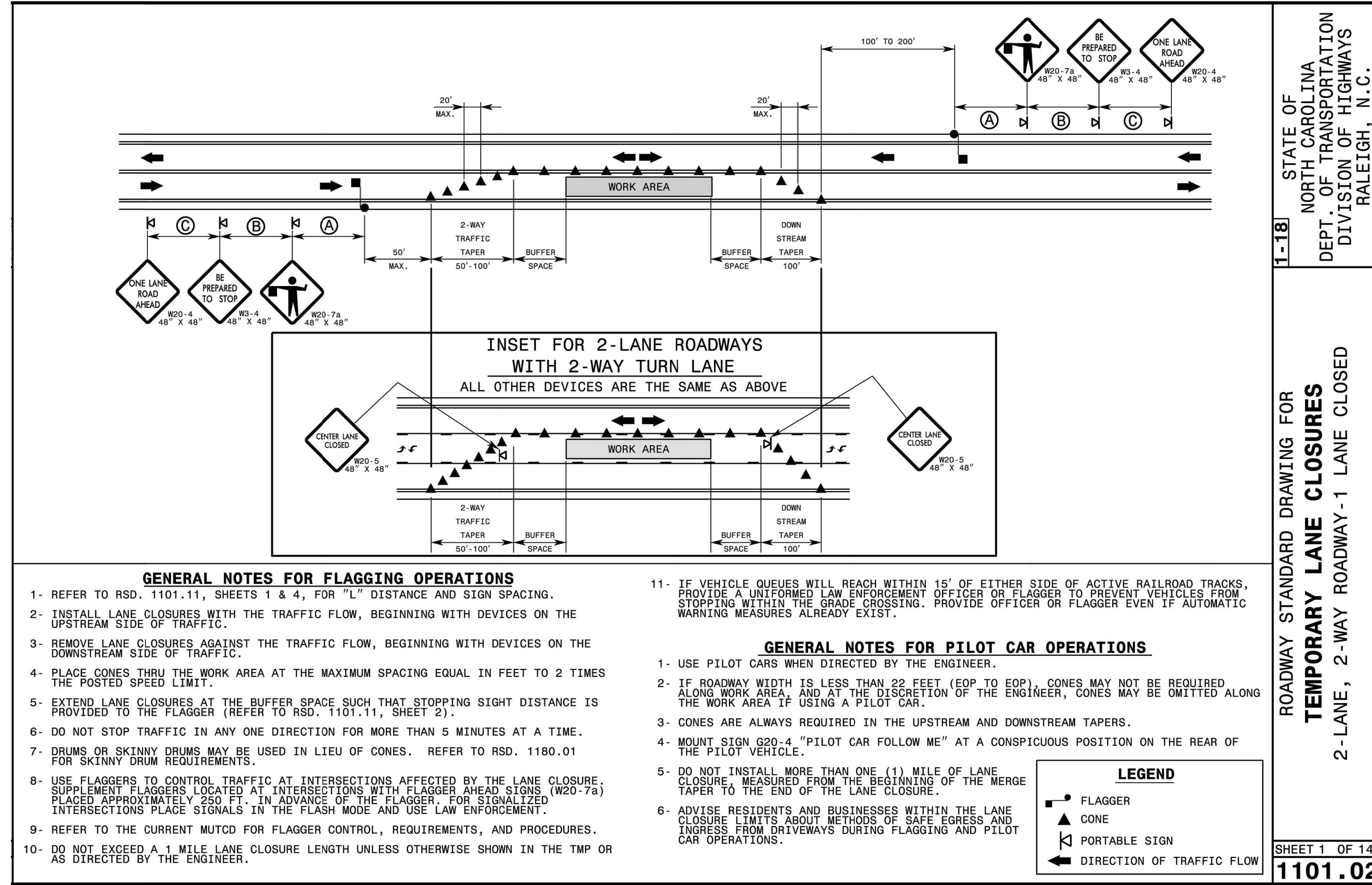

TRANSPORTATION NOTES:

- ALL SIGNAGE SHALL ADHERE TO MUTCD STANDARDS AND SPECIFICATIONS.
- IF AN APPROVAL FOR A TRAFFIC CONTROL AND PEDESTRIAN ROUTING SETUP FOR WATER AND SEWER INSTALLATION IS REQUESTED PRIOR TO THE INSTALLATION, PLEASE SEND A PLAN TO RIGHTOFWAYSERVICES@RALEIGHNC.GOV. PLEASE ALLOW 5 BUSINESS DAYS FOR REVIEW.
- THE SIDEWALK AND PAVEMENT SHALL BE FREE AND CLEAR OF DEBRIS AT ALL TIMES.
- ALL SIDEWALKS ARE PUBLIC AND MUST BE ACCESSIBLE TO PEDESTRIANS WHO ARE VISUALLY IMPAIRED AND/OR PEOPLE WITH MOBILITY DISABILITIES. EXISTING AND ALTERNATIVE PEDESTRIAN ROUTES DURING CONSTRUCTION SHALL BE COMPLIANT WITH THE PUBLIC RIGHTS OF WAY ACCESSIBILITY GUIDELINES (PROWAG), 2010 ADA STANDARDS FOR ACCESSIBLE DESIGN AND THE MANUAL ON UNIFORM TRAFFIC CONTROL DEVICES (MUTCD).
- CONSTRUCTION FENCING SHOULD NOT ENCRoACH INTO THE PUBLIC RIGHT OF WAY. IF IT DOES, IT MUST BE MOVABLE IN CASE ADJUSTMENTS HAVE TO BE MADE. NO DRILLING, BORING OR ANY PERMANENT FASTENING OF THE FENCE IS ALLOWED IN THE PUBLIC RIGHT OF WAY.
- ACCESS TO ALL DRIVEWAYS AND SIDE STREETS SHALL BE MAINTAINED AT ALL TIMES.
- CONTRACTOR SHALL MAINTAIN AT LEAST ONE LANE OF TRAFFIC ON VIRGINIA WATER DRIVE AND TRILICK COURT DURING CONSTRUCTION PERIOD. IF IT IS NECESSARY TO CLOSE AN ENTIRE ROAD DURING CONSTRUCTION, THE CONTRACTOR SHALL OBTAIN A ROAD CLOSURE PERMIT FROM THE TOWN OF ROLESVILLE AT NO ADDITIONAL COST. ROAD CLOSURE PLAN SHALL BE IN ACCORDANCE TO THE TOWN OF ROLESVILLE AND NCDOT GUIDELINES.
- IF THE TOWN OF ROLESVILLE ALLOWS EXCAVATED MATERIALS STORAGE ON PAVEMENT, A LAYER OF COARSE SAND, SCREENING, OR ACCEPTABLE ALTERNATIVE SHALL BE PLACED ON THE PAVEMENT PRIOR TO DEPOSITION OF EXCAVATED MATERIAL.
- ALL TRAFFIC SHALL BE RESTORED TO TWO-WAY TRAFFIC AT THE END OF EACH WORKDAY.

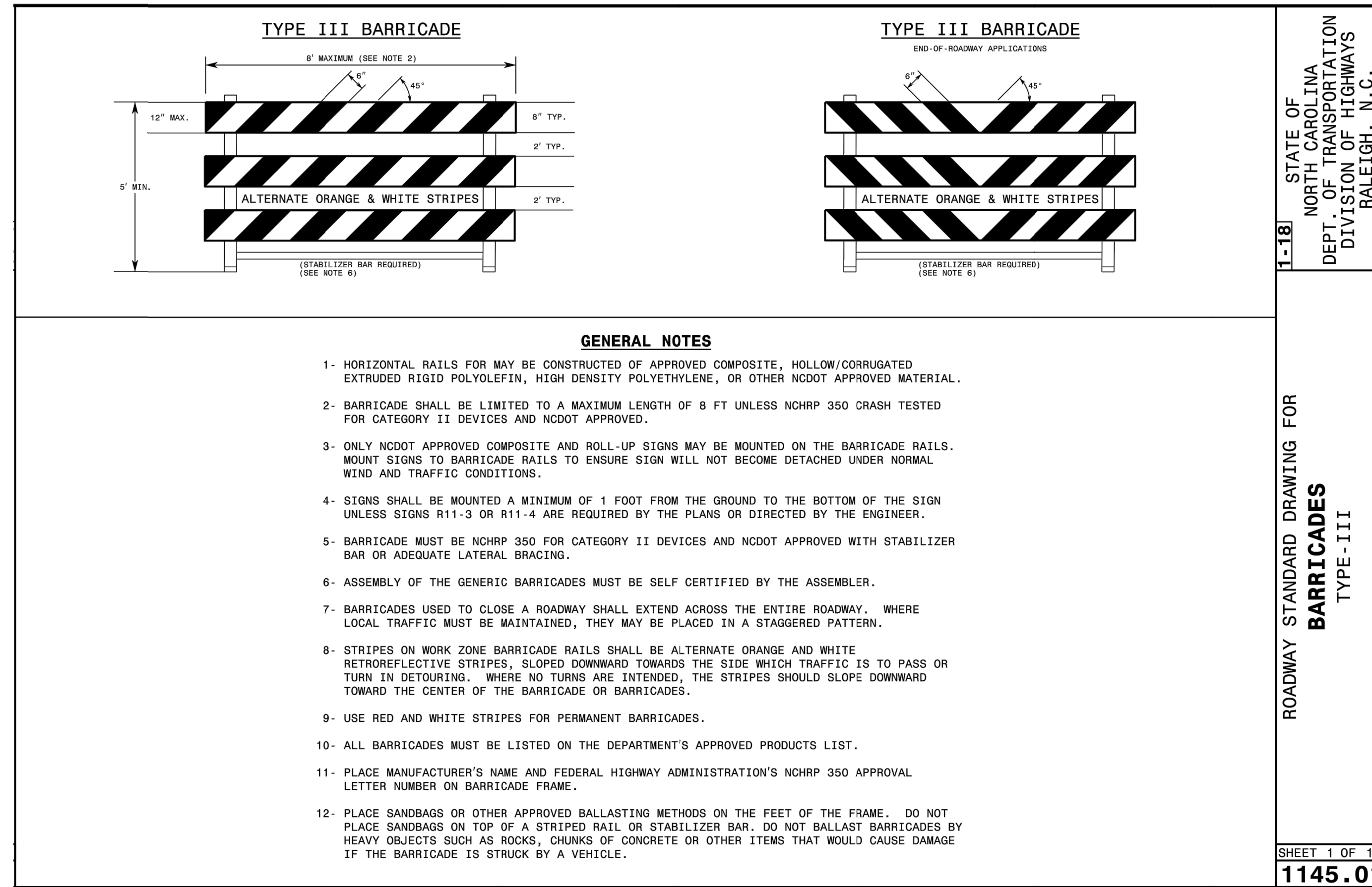
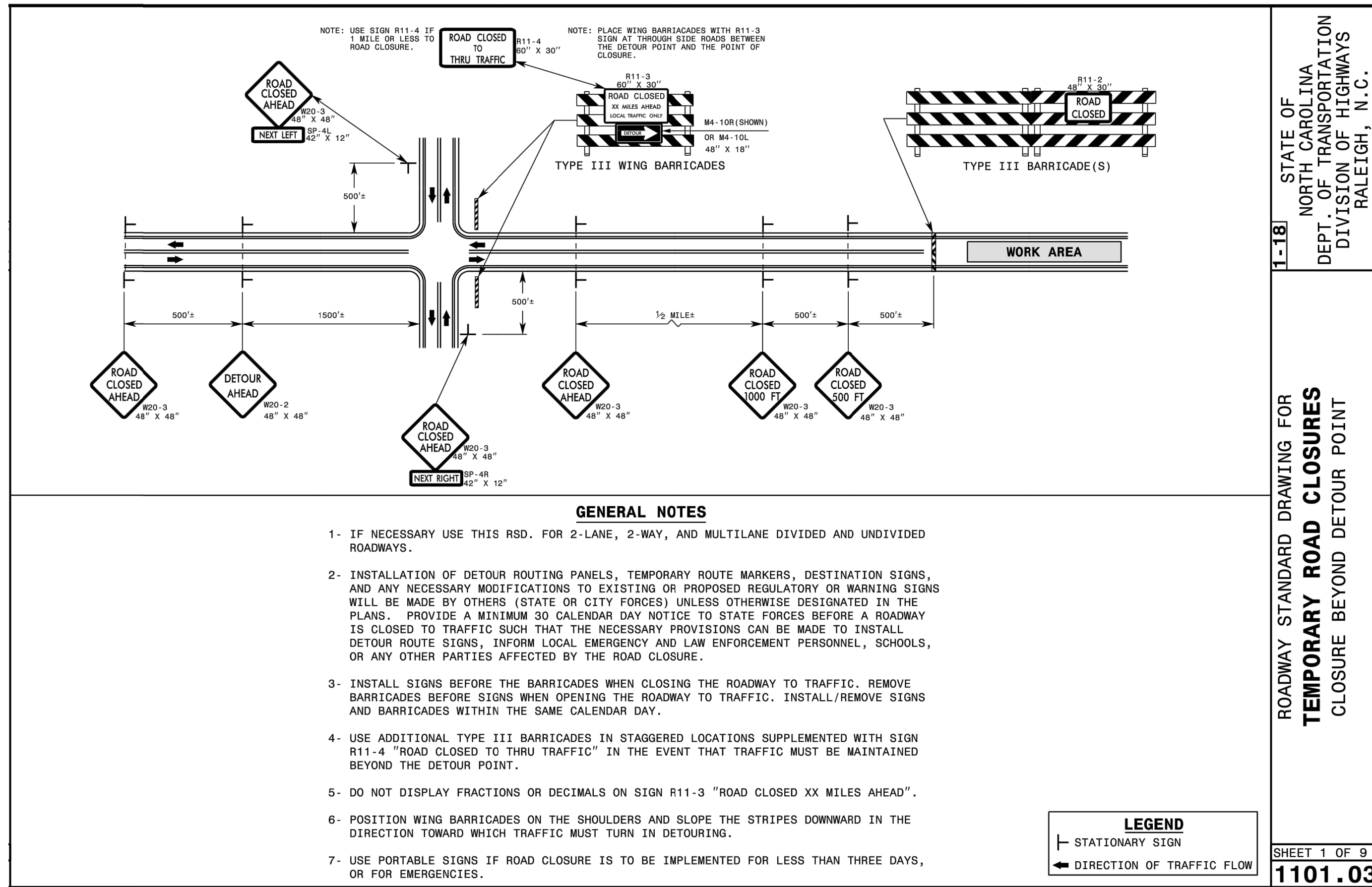

NOTE: ALL CONSTRUCTION SHALL ADHERE TO CITY OF RALEIGH STANDARDS AND SPECIFICATIONS
 CITY OF RALEIGH - PLANS AUTHORIZED FOR CONSTRUCTION

Plans for the proposed use have been reviewed for general compliance with applicable codes. This limited review, and authorization for construction is not to be considered to represent total compliance with all legal requirements for development and construction. The property owner, design consultants, and contractors are each responsible for compliance with all applicable City, State and Federal laws. This specific authorization below is not a permit, nor shall it be construed to permit any violation of City, State or Federal Law. All construction must be in accordance with all Local, State, and Federal Rules and Regulations. This approval of this electronic document is only valid if the document has not been modified and the digital signature below is valid.

CD 22-06

WALLBROOK OFFSITE UTILITY IMPROVEMENTS
 WALLBROOK LANDCO
 ROLESVILLE, NC

TRAFFIC CONTROL DETAILS

STATE OF NORTH CAROLINA
 DEPT. OF TRANSPORTATION
 DIVISION OF HIGHWAYS
 RALEIGH, N.C.

ROADWAY STANDARD DRAWING FOR
 BARRICADES
 TYPE - III

SHEET 1 OF 1
1145.01

STATE OF NORTH CAROLINA
 DEPT. OF TRANSPORTATION
 DIVISION OF HIGHWAYS
 RALEIGH, N.C.

ROADWAY STANDARD DRAWING FOR
 TEMPORARY LANE CLOSURES
 2-LANE, 2-WAY ROADWAY - 1 LANE CLOSED

SHEET 1 OF 14
1101.02

STATE OF NORTH CAROLINA
 DEPT. OF TRANSPORTATION
 DIVISION OF HIGHWAYS
 RALEIGH, N.C.

ROADWAY STANDARD DRAWING FOR
 TEMPORARY ROAD CLOSURES
 CLOSURE BEYOND DETOUR POINT

SHEET 1 OF 9
1101.03

STATE OF NORTH CAROLINA
 DEPT. OF TRANSPORTATION
 DIVISION OF HIGHWAYS
 RALEIGH, N.C.

ROADWAY STANDARD DRAWING FOR
 TEMPORARY LANE CLOSURES
 2-LANE, 2-WAY ROADWAY - 1 LANE CLOSED

SHEET 1 OF 14
1101.02

STATE OF NORTH CAROLINA
 DEPT. OF TRANSPORTATION
 DIVISION OF HIGHWAYS
 RALEIGH, N.C.

ROADWAY STANDARD DRAWING FOR
 TEMPORARY LANE CLOSURES
 2-LANE, 2-WAY ROADWAY - 1 LANE CLOSED

SHEET 1 OF 14
1101.02

STATE OF NORTH CAROLINA
 DEPT. OF TRANSPORTATION
 DIVISION OF HIGHWAYS
 RALEIGH, N.C.

ROADWAY STANDARD DRAWING FOR
 TEMPORARY LANE CLOSURES
 2-LANE, 2-WAY ROADWAY - 1 LANE CLOSED

SHEET 1 OF 14
1101.02

STATE OF NORTH CAROLINA
 DEPT. OF TRANSPORTATION
 DIVISION OF HIGHWAYS
 RALEIGH, N.C.

ROADWAY STANDARD DRAWING FOR
 TEMPORARY LANE CLOSURES
 2-LANE, 2-WAY ROADWAY - 1 LANE CLOSED

SHEET 1 OF 14
1101.02

STATE OF NORTH CAROLINA
 DEPT. OF TRANSPORTATION
 DIVISION OF HIGHWAYS
 RALEIGH, N.C.

ROADWAY STANDARD DRAWING FOR
 TEMPORARY LANE CLOSURES
 2-LANE, 2-WAY ROADWAY - 1 LANE CLOSED

SHEET 1 OF 14
1101.02

STATE OF NORTH CAROLINA
 DEPT. OF TRANSPORTATION
 DIVISION OF HIGHWAYS
 RALEIGH, N.C.

ROADWAY STANDARD DRAWING FOR
 TEMPORARY LANE CLOSURES
 2-LANE, 2-WAY ROADWAY - 1 LANE CLOSED

SHEET 1 OF 14
1101.02

STATE OF NORTH CAROLINA
 DEPT. OF TRANSPORTATION
 DIVISION OF HIGHWAYS
 RALEIGH, N.C.

ROADWAY STANDARD DRAWING FOR
 TEMPORARY LANE CLOSURES
 2-LANE, 2-WAY ROADWAY - 1 LANE CLOSED

SHEET 1 OF 14
1101.02

STATE OF NORTH CAROLINA
 DEPT. OF TRANSPORTATION
 DIVISION OF HIGHWAYS
 RALEIGH, N.C.

ROADWAY STANDARD DRAWING FOR
 TEMPORARY LANE CLOSURES
 2-LANE, 2-WAY ROADWAY - 1 LANE CLOSED

SHEET 1 OF 14
1101.02

STATE OF NORTH CAROLINA
 DEPT. OF TRANSPORTATION
 DIVISION OF HIGHWAYS
 RALEIGH, N.C.

ROADWAY STANDARD DRAWING FOR
 TEMPORARY LANE CLOSURES
 2-LANE, 2-WAY ROADWAY - 1 LANE CLOSED

SHEET 1 OF 14
1101.02

STATE OF NORTH CAROLINA
 DEPT. OF TRANSPORTATION
 DIVISION OF HIGHWAYS
 RALEIGH, N.C.

ROADWAY STANDARD DRAWING FOR
 TEMPORARY LANE CLOSURES
 2-LANE, 2-WAY ROADWAY - 1 LANE CLOSED

SHEET 1 OF 14
1101.02

STATE OF NORTH CAROLINA
 DEPT. OF TRANSPORTATION
 DIVISION OF HIGHWAYS
 RALEIGH, N.C.

ROADWAY STANDARD DRAWING FOR
 TEMPORARY LANE CLOSURES
 2-LANE, 2-WAY ROADWAY - 1 LANE CLOSED

SHEET 1 OF 14
1101.02

STATE OF NORTH CAROLINA
 DEPT. OF TRANSPORTATION
 DIVISION OF HIGHWAYS
 RALEIGH, N.C.

ROADWAY STANDARD DRAWING FOR
 TEMPORARY LANE CLOSURES
 2-LANE, 2-WAY ROADWAY - 1 LANE CLOSED

SHEET 1 OF 14
1101.02

STATE OF NORTH CAROLINA
 DEPT. OF TRANSPORTATION
 DIVISION OF HIGHWAYS
 RALEIGH, N.C.

ROADWAY STANDARD DRAWING FOR
 TEMPORARY LANE CLOSURES
 2-LANE, 2-WAY ROADWAY - 1 LANE CLOSED

SHEET 1 OF 14
1101.02

STATE OF NORTH CAROLINA
 DEPT. OF TRANSPORTATION
 DIVISION OF HIGHWAYS
 RALEIGH, N.C.

ROADWAY STANDARD DRAWING FOR
 TEMPORARY LANE CLOSURES
 2-LANE, 2-WAY ROADWAY - 1 LANE CLOSED

SHEET 1 OF 14
1101.02

STATE OF NORTH CAROLINA
 DEPT. OF TRANSPORTATION
 DIVISION OF HIGHWAYS
 RALEIGH, N.C.

ROADWAY STANDARD DRAWING FOR
 TEMPORARY LANE CLOSURES
 2-LANE, 2-WAY ROADWAY - 1 LANE CLOSED

SHEET 1 OF 14
1101.02

STATE OF NORTH CAROLINA
 DEPT. OF TRANSPORTATION
 DIVISION OF HIGHWAYS
 RALEIGH, N.C.

ROADWAY STANDARD DRAWING FOR
 TEMPORARY LANE CLOSURES
 2-LANE, 2-WAY ROADWAY - 1 LANE CLOSED

SHEET 1 OF 14
1101.02

STATE OF NORTH CAROLINA
 DEPT. OF TRANSPORTATION
 DIVISION OF HIGHWAYS
 RALEIGH, N.C.

ROADWAY STANDARD DRAWING FOR
 TEMPORARY LANE CLOSURES
 2-LANE, 2-WAY ROADWAY - 1 LANE CLOSED

SHEET 1 OF 14
1101.02

STATE OF NORTH CAROLINA
 DEPT. OF TRANSPORTATION
 DIVISION OF HIGHWAYS
 RALEIGH, N.C.

ROADWAY STANDARD DRAWING FOR
 TEMPORARY LANE CLOSURES
 2-LANE, 2-WAY ROADWAY - 1 LANE CLOSED

SHEET 1 OF 14
1101.02

STATE OF NORTH CAROLINA
 DEPT. OF TRANSPORTATION
 DIVISION OF HIGHWAYS
 RALEIGH, N.C.

ROADWAY STANDARD DRAWING FOR
 TEMPORARY LANE CLOSURES
 2-LANE, 2-WAY ROADWAY - 1 LANE CLOSED

SHEET 1 OF 14
1101.02

STATE OF NORTH CAROLINA
 DEPT. OF TRANSPORTATION
 DIVISION OF HIGHWAYS
 RALEIGH, N.C.

ROADWAY STANDARD DRAWING FOR
 TEMPORARY LANE CLOSURES
 2-LANE, 2-WAY ROADWAY - 1 LANE CLOSED

SHEET 1 OF 14
1101.02

STATE OF NORTH CAROLINA
 DEPT. OF TRANSPORTATION
 DIVISION OF HIGHWAYS
 RALEIGH, N.C.

ROADWAY STANDARD DRAWING FOR
 TEMPORARY LANE CLOSURES
 2-LANE, 2-WAY ROADWAY - 1 LANE CLOSED

SHEET 1 OF 14
1101.02

STATE OF NORTH CAROLINA
 DEPT. OF TRANSPORTATION
 DIVISION OF HIGHWAYS
 RALEIGH, N.C.

ROADWAY STANDARD DRAWING FOR
 TEMPORARY LANE CLOSURES
 2-LANE, 2-WAY ROADWAY - 1 LANE CLOSED

SHEET 1 OF 14
1101.02

STATE OF NORTH CAROLINA
 DEPT. OF TRANSPORTATION
 DIVISION OF HIGHWAYS
 RALEIGH, N.C.

ROADWAY STANDARD DRAWING FOR
 TEMPORARY LANE CLOSURES
 2-LANE, 2-WAY ROADWAY - 1 LANE CLOSED

SHEET 1 OF 14
1101.02

STATE OF NORTH CAROLINA
 DEPT. OF TRANSPORTATION
 DIVISION OF HIGHWAYS
 RALEIGH, N.C.

ROADWAY STANDARD DRAWING FOR
 TEMPORARY LANE CLOSURES
 2-LANE, 2-WAY ROADWAY - 1 LANE CLOSED

SHEET 1 OF 14
1101.02

STATE OF NORTH CAROLINA
 DEPT. OF TRANSPORTATION
 DIVISION OF HIGHWAYS
 RALEIGH, N.C.

ROADWAY STANDARD DRAWING FOR
 TEMPORARY LANE CLOSURES
 2-LANE, 2-WAY ROADWAY - 1 LANE CLOSED

SHEET 1 OF 14
1101.02

STATE OF NORTH CAROLINA
 DEPT. OF TRANSPORTATION
 DIVISION OF HIGHWAYS
 RALEIGH, N.C.

ROADWAY STANDARD DRAWING FOR
 TEMPORARY LANE CLOSURES
 2-LANE, 2-WAY ROADWAY - 1 LANE CLOSED

SHEET 1 OF 14
1101.02

STATE OF NORTH CAROLINA
 DEPT. OF TRANSPORTATION
 DIVISION OF HIGHWAYS
 RALEIGH, N.C.

ROADWAY STANDARD DRAWING FOR
 TEMPORARY LANE CLOSURES
 2-LANE, 2-WAY ROADWAY - 1 LANE CLOSED

SHEET 1 OF 14
1101.02

STATE OF NORTH CAROLINA
 DEPT. OF TRANSPORTATION
 DIVISION OF HIGHWAYS
 RALEIGH, N.C.

ROADWAY STANDARD DRAWING FOR
 TEMPORARY LANE CLOSURES
 2-LANE, 2-WAY ROADWAY - 1 LANE CLOSED

SHEET 1 OF 14
1101.02

STATE OF NORTH CAROLINA
 DEPT. OF TRANSPORTATION
 DIVISION OF HIGHWAYS
 RALEIGH, N.C.

ROADWAY STANDARD DRAWING FOR
 TEMPORARY LANE CLOSURES
 2-LANE, 2-WAY ROADWAY - 1 LANE CLOSED

SHEET 1 OF 14
1101.02

STATE OF NORTH CAROLINA
 DEPT. OF TRANSPORTATION
 DIVISION OF HIGHWAYS
 RALEIGH, N.C.

ROADWAY STANDARD DRAWING FOR
 TEMPORARY LANE CLOSURES
 2-LANE, 2-WAY ROADWAY - 1 LANE CLOSED

SHEET 1 OF 14
1101.02

STATE OF NORTH CAROLINA
 DEPT. OF TRANSPORTATION
 DIVISION OF HIGHWAYS
 RALEIGH, N.C.

ROADWAY STANDARD DRAWING FOR
 TEMPORARY LANE CLOSURES
 2-LANE, 2-WAY ROADWAY - 1 LANE CLOSED

SHEET 1 OF 14
1101.02

STATE OF NORTH CAROLINA
 DEPT. OF TRANSPORTATION
 DIVISION OF HIGHWAYS
 RALEIGH, N.C.

ROADWAY STANDARD DRAWING FOR
 TEMPORARY LANE CLOSURES
 2-LANE, 2-WAY ROADWAY - 1 LANE CLOSED

SHEET 1 OF 14
1101.02

STATE OF NORTH CAROLINA
 DEPT. OF TRANSPORTATION
 DIVISION OF HIGHWAYS
 RALEIGH, N.C.

ROADWAY STANDARD DRAWING FOR
 TEMPORARY LANE CLOSURES
 2-LANE, 2-WAY ROADWAY - 1 LANE CLOSED

SHEET 1 OF 14
1101.02

STATE OF NORTH CAROLINA
 DEPT. OF TRANSPORTATION
 DIVISION OF HIGHWAYS
 RALEIGH, N.C.

ROADWAY STANDARD DRAWING FOR
 TEMPORARY LANE CLOSURES
 2-LANE, 2-WAY ROADWAY - 1 LANE CLOSED

SHEET 1 OF 14
1101.02

STATE OF NORTH CAROLINA
 DEPT. OF TRANSPORTATION
 DIVISION OF HIGHWAYS
 RALEIGH, N.C.

ROADWAY STANDARD DRAWING FOR
 TEMPORARY LANE CLOSURES
 2-LANE, 2-WAY ROADWAY - 1 LANE CLOSED

SHEET 1 OF 14
1101.02

STATE OF NORTH CAROLINA
 DEPT. OF TRANSPORTATION
 DIVISION OF HIGHWAYS
 RALEIGH, N.C.

ROADWAY STANDARD DRAWING FOR
 TEMPORARY LANE CLOSURES
 2-LANE, 2-WAY ROADWAY - 1 LANE CLOSED

SHEET 1 OF 14
1101.02

STATE OF NORTH CAROLINA
 DEPT. OF TRANSPORTATION
 DIVISION OF HIGHWAYS
 RALEIGH, N.C.

ROADWAY STANDARD DRAWING FOR
 TEMPORARY LANE CLOSURES
 2-LANE, 2-WAY ROADWAY - 1 LANE CLOSED

SHEET 1 OF 14
1101.02

STATE OF NORTH CAROLINA
 DEPT. OF TRANSPORTATION
 DIVISION OF HIGHWAYS
 RALEIGH, N.C.

ROADWAY STANDARD DRAWING FOR
 TEMPORARY LANE CLOSURES
 2-LANE, 2-WAY ROADWAY - 1 LANE CLOSED

SHEET 1 OF 14
1101.02

STATE OF NORTH CAROLINA
 DEPT. OF TRANSPORTATION
 DIVISION OF HIGHWAYS
 RALEIGH, N.C.

ROADWAY STANDARD DRAWING FOR
 TEMPORARY LANE CLOSURES
 2-LANE, 2-WAY ROADWAY - 1 LANE CLOSED

SHEET 1 OF 14
1101.02

STATE OF NORTH CAROLINA
 DEPT. OF TRANSPORTATION
 DIVISION OF HIGHWAYS
 RALEIGH, N.C.

ROADWAY STANDARD DRAWING FOR
 TEMPORARY LANE CLOSURES
 2-LANE, 2-WAY ROADWAY - 1 LANE CLOSED

SHEET 1 OF 14
1101.02

STATE OF NORTH CAROLINA
 DEPT. OF TRANSPORTATION
 DIVISION OF HIGHWAYS
 RALEIGH, N.C.

ROADWAY STANDARD DRAWING FOR
 TEMPORARY LANE CLOSURES
 2-LANE, 2-WAY ROADWAY - 1 LANE CLOSED

SHEET 1 OF 14
1101.02

STATE OF NORTH CAROLINA
 DEPT. OF TRANSPORTATION
 DIVISION OF HIGHWAYS
 RALEIGH, N.C.

ROADWAY STANDARD DRAWING FOR
 TEMPORARY LANE CLOSURES
 2-LANE, 2-WAY ROADWAY - 1 LANE CLOSED

SHEET 1 OF 14
1101.02

STATE OF NORTH CAROLINA
 DEPT. OF TRANSPORTATION
 DIVISION OF HIGHWAYS
 RALEIGH, N.C.

ROADWAY STANDARD DRAWING FOR
 TEMPORARY LANE CLOSURES
 2-LANE, 2-WAY ROADWAY - 1 LANE CLOSED

SHEET 1 OF 14
1101.02

STATE OF NORTH CAROLINA
 DEPT. OF TRANSPORTATION
 DIVISION OF HIGHWAYS
 RALEIGH, N.C.

ROADWAY STANDARD DRAWING FOR
 TEMPORARY LANE CLOSURES
 2-LANE, 2-WAY ROADWAY - 1 LANE CLOSED

SHEET 1 OF 14
1101.02

STATE OF NORTH CAROLINA
 DEPT. OF TRANSPORTATION
 DIVISION OF HIGHWAYS
 RALEIGH, N.C.

ROADWAY STANDARD DRAWING FOR
 TEMPORARY LANE CLOSURES
 2-LANE, 2-WAY ROADWAY - 1 LANE CLOSED

SHEET 1 OF 14
1101.02

STATE OF NORTH CAROLINA
 DEPT. OF TRANSPORTATION
 DIVISION OF HIGHWAYS
 RALEIGH, N.C.

ROADWAY STANDARD DRAWING FOR
 TEMPORARY LANE CLOSURES
 2-LANE, 2-WAY ROADWAY - 1 LANE CLOSED

SHEET 1 OF 14
1101.02

STATE OF NORTH CAROLINA
 DEPT. OF TRANSPORTATION
 DIVISION OF HIGHWAYS
 RALEIGH, N.C.

ROADWAY STANDARD DRAWING FOR
 TEMPORARY LANE CLOSURES
 2-LANE, 2-WAY ROADWAY - 1 LANE CLOSED

SHEET 1 OF 14
1101.02

STATE OF NORTH CAROLINA
 DEPT. OF TRANSPORTATION
 DIVISION OF HIGHWAYS
 RALEIGH, N.C.

ROADWAY STANDARD DRAWING FOR
 TEMPORARY LANE CLOSURES
 2-LANE, 2-WAY ROADWAY - 1 LANE CLOSED

SHEET 1 OF 14
1101.02

STATE OF NORTH CAROLINA
 DEPT. OF TRANSPORTATION
 DIVISION OF HIGHWAYS
 RALEIGH, N.C.

ROADWAY STANDARD DRAWING FOR
 TEMPORARY LANE CLOSURES
 2-LANE, 2-WAY ROADWAY - 1 LANE CLOSED

SHEET 1 OF 14
1101.02

STATE OF NORTH CAROLINA
 DEPT. OF TRANSPORTATION
 DIVISION OF HIGHWAYS
 RALEIGH, N.C.

ROADWAY STANDARD DRAWING FOR
 TEMPORARY LANE CLOSURES
 2-LANE, 2-WAY ROADWAY - 1 LANE CLOSED

SHEET 1 OF 14
1101.02

STATE OF NORTH CAROLINA
 DEPT. OF TRANSPORTATION
 DIVISION OF HIGHWAYS
 RALEIGH, N.C.

ROADWAY STANDARD DRAWING FOR
 TEMPORARY LANE CLOSURES
 2-LANE, 2-WAY ROADWAY - 1 LANE CLOSED

SHEET 1 OF 14
1101.02

STATE OF NORTH CAROLINA
 DEPT. OF TRANSPORTATION
 DIVISION OF HIGHWAYS
 RALEIGH, N.C.

ROADWAY STANDARD DRAWING FOR
 TEMPORARY LANE CLOSURES
 2-LANE, 2-WAY ROADWAY - 1 LANE CLOSED

SHEET 1 OF 14
1101.02

STATE OF NORTH CAROLINA
 DEPT. OF TRANSPORTATION
 DIVISION OF HIGHWAYS
 RALEIGH, N.C.

ROADWAY STANDARD DRAWING FOR
 TEMPORARY LANE CLOSURES
 2-LANE, 2-WAY ROADWAY - 1 LANE CLOSED

SHEET 1 OF 14
1101.02

STATE OF NORTH CAROLINA
 DEPT. OF TRANSPORTATION
 DIVISION OF HIGHWAYS
 RALEIGH, N.C.

ROADWAY STANDARD DRAWING FOR
 TEMPORARY LANE CLOSURES
 2-LANE, 2-WAY ROADWAY - 1 LANE CLOSED

SHEET 1 OF 14
1101.02

STATE OF NORTH CAROLINA
 DEPT. OF TRANSPORTATION
 DIVISION OF HIGHWAYS
 RALEIGH, N.C.

ROADWAY STANDARD DRAWING FOR
 TEMPORARY LANE CLOSURES
 2-LANE, 2-WAY ROADWAY - 1 LANE CLOSED

SHEET 1 OF 14
1101.02

STATE OF NORTH CAROLINA
 DEPT. OF TRANSPORTATION
 DIVISION OF HIGHWAYS
 RALEIGH, N.C.

ROADWAY STANDARD DRAWING FOR
 TEMPORARY LANE CLOSURES
 2-LANE, 2-WAY ROADWAY - 1 LANE CLOSED

SHEET 1 OF 14
1101.02

STATE OF NORTH CAROLINA
 DEPT. OF TRANSPORTATION
 DIVISION OF HIGHWAYS
 RALEIGH, N.C.

ROADWAY STANDARD DRAWING FOR
 TEMPORARY LANE CLOSURES
 2-LANE, 2-WAY ROADWAY - 1 LANE CLOSED

SHEET 1 OF 14
1101.02

STATE OF NORTH CAROLINA
 DEPT. OF TRANSPORTATION
 DIVISION OF HIGHWAYS
 RALEIGH, N.C.

ROADWAY STANDARD DRAWING FOR
 TEMPORARY LANE CLOSURES
 2-LANE, 2-WAY ROADWAY - 1 LANE CLOSED

SHEET 1 OF 14
1101.02

STATE OF NORTH CAROLINA
 DEPT. OF TRANSPORTATION
 DIVISION OF HIGHWAYS
 RALEIGH, N.C.

ROADWAY STANDARD DRAWING FOR
 TEMPORARY LANE CLOSURES
 2-LANE, 2-WAY ROADWAY - 1 LANE CLOSED

SHEET 1 OF 14
1101.02

STATE OF NORTH CAROLINA
 DEPT. OF TRANSPORTATION
 DIVISION OF HIGHWAYS
 RALEIGH, N.C.

ROADWAY STANDARD DRAWING FOR
 TEMPORARY LANE CLOSURES
 2-LANE, 2-WAY ROADWAY - 1 LANE CLOSED

SHEET 1 OF 14
1101.02

STATE OF NORTH CAROLINA
 DEPT. OF TRANSPORTATION
 DIVISION OF HIGHWAYS
 RALEIGH, N.C.

ROADWAY STANDARD DRAWING FOR
 TEMPORARY LANE CLOSURES
 2-LANE, 2-WAY ROADWAY - 1 LANE CLOSED

SHEET 1 OF 14
1101.02

STATE OF NORTH CAROLINA
 DEPT. OF TRANSPORTATION
 DIVISION OF HIGHWAYS
 RALEIGH, N.C.

ROADWAY STANDARD DRAWING FOR
 TEMPORARY LANE CLOSURES
 2-LANE, 2-WAY ROADWAY - 1 LANE CLOSED

SHEET 1 OF 14
1101.02

STATE OF NORTH CAROLINA
 DEPT. OF TRANSPORTATION
 DIVISION OF HIGHWAYS
 RALEIGH, N.C.

ROADWAY STANDARD DRAWING FOR
 TEMPORARY LANE CLOSURES
 2-LANE, 2-WAY ROADWAY - 1 LANE CLOSED

SHEET 1 OF 14
1101.02

STATE OF NORTH CAROLINA
 DEPT. OF TRANSPORTATION
 DIVISION OF HIGHWAYS
 RALEIGH, N.C.

ROADWAY STANDARD DRAWING FOR
 TEMPORARY LANE CLOSURES
 2-LANE, 2-WAY ROADWAY - 1 LANE CLOSED

SHEET 1 OF 14
1101.02

STATE OF NORTH CAROLINA
 DEPT. OF TRANSPORTATION
 DIVISION OF HIGHWAYS
 RALEIGH, N.C.

ROADWAY STANDARD DRAWING FOR
 TEMPORARY LANE CLOSURES
 2-LANE, 2-WAY ROADWAY - 1 LANE CLOSED

SHEET 1 OF 14
1101.02

STATE OF NORTH CAROLINA
 DEPT. OF TRANSPORTATION
 DIVISION OF HIGHWAYS
 RALEIGH, N.C.

ROADWAY STANDARD DRAWING FOR
 TEMPORARY LANE CLOSURES
 2-LANE, 2